

PHILIPS

Data handbook



Electronic
components
and materials

Components and
materials

Book C2

1987

Television tuners

Coaxial aerial input assemblies

TELEVISION TUNERS

	<i>page</i>
Selection guides	
V.H.F./U.H.F. television tuners	3
V.H.F. television tuners.	6
U.H.F. television tuners.	6
Coaxial aerial input assemblies	8
Pin compatibility	9
Device specifications	
Television tuners	11
Coaxial aerial input assemblies	301
Conversion list (catalogue number-to-type number)	321

SELECTION GUIDES

V.H.F./U.H.F. TUNERS

	FE617Q FE618Q	USF10 USF10A	M33 M34	UV411 UV412	UV411HKM
System	C.C.I.R.: B,G,H	C.C.I.R.: L,L'	R.T.M.A.: M,N	C.C.I.R.: B,G	C.C.I.R.: D
Channels					
v.h.f.	E2 to C*	E2 to E4 *	A2 to A6	N21 to C	C1 to C5
u.h.f.	E5 to E12 E21 to E69	M4 to E12 L21 to L69	A7 to A13 A14 to A83	M4 to E12 E21 to E69	C6 to C12 C13 to C57
Frequency ranges (MHz)	46 to 110 111 to 300 470 to 861	48 to 68 128 to 306 470 to 861	54 to 88 174 to 216 470 to 890	44 to 92 162 to 230 470 to 861	48 to 92 167 to 224 470 to 870
I.F. frequency (MHz)					
picture	38,9	32,7	45,75	38,9	37,0
sound	33,4	39,2	41,25	33,4	30,5
Divider ratio	256 (FE618Q only)	256 (USF10A only)	256 or 64 (M34 only)	256 or 64 (UV412 only)	—
Supply voltage	+ 12 V ± 10%	+ 12 V ± 1 V	+ 12 V ± 10%	+ 12 V ± 10%	+ 12 V ± 10%
Tuning voltage	+ 0,8 to + 28 V	+ 0,5 to + 28 V	+ 0,65 to + 28 V	+ 1 to + 28 V	+ 1 to + 28 V
A.G.C. voltage	+ 2,5 V to + 7 V	+ 8,25 to + 0,85 V	+ 10 to 0 V	+ 9,2 to + 0,85 V	+ 9,2 to + 0,85 V
Amplification, typical	—	20 dB	32 dB	26 dB	27 dB
Noise figure, typical	—	7 dB	8 dB	5 dB	5 dB
Overall dimensions					
l x w x h (mm)	147 x 20 x 55	94 x 24 x 73	86 x 23 x 81	95 x 23 x 77	95 x 23 x 77
Aerial input plug	IEC	coaxial female plug on cable	phono	phono or IEC	IEC
Meets Amtsblatt DBP69/1981	no	no	no	no	no
Page	25	121	39	133	149
	* cable: S01 to S1 S2 to S20	* cable: C to Q			

SELECTION GUIDES

V.H.F./U.H.F. TUNERS					
	UV417/MK2 UV418/MK2	UV431	UV461 UV462	UV471 UV472	UV615 UV616
System	C.C.I.R.: B,G	R.T.M.A.: M,N	C.C.I.R.: B,G	C.C.I.R.: I	C.C.I.R.: B,G,H
Channels v.h.f.	E2 to C*	A2 to A6	0 to 4	4 to 13	E2 to C*
u.h.f.	E5 to E12 E21 to E69	A7 to A13 A14 to A83	5 to 11 28 to 63	21 to 69	E5 to E12 E12 to E69
Frequency ranges (MHz)	47 to 111 111 to 300 470 to 860	55,25 to 83,25 175,25 to 211,25 471,25 to 885,25	45 to 101 101 to 222 526 to 814	— 174 to 254 470 to 860	46 to 110 111 to 300 300 to 470 470 to 860
I.F. frequency (MHz) picture sound	38,9 33,4	45,75 41,25	38,875 31,375	38,9 32,9	38,9 33,4
Divider ratio	256 or 64 (UV418 only)	—	256 (UV462 only)	—	256 (UV616 only)
Supply voltage	+ 12 V ± 10%	+ 12 V ± 10%	+ 12 V ± 10%	+ 12 V ± 10%	+ 12 V ± 10%
Tuning voltage	+ 1 to + 28 V	+ 1 to + 28 V	+ 1 to + 28 V	+ 1 to + 28 V	+ 1 to + 28 V
A.G.C. voltage	+ 9,2 to + 0,85 V	+ 9,2 to + 0,85 V	+ 9,2 to + 0,85 V	+ 9,2 to + 0,85 V	+ 9,2 to + 0,85 V
Amplification, typical	18 dB	26 dB	24 dB	24 dB	40 dB
Noise figure, typical	8 dB	5 dB	7 dB	6 dB	6 dB
Overall dimensions l x w x h (mm)	95 x 23 x 77	95 x 23 x 77	95 x 23 x 77	95 x 23 x 77	84 x 20 x 55
Aerial input plug	phono or IEC	phono	phono or IEC	phono	IEC
Meets Amtsblatt DBP69/1981	yes	no	no	no	yes
Page	165	177	193	209	223
	* cable: S01 to S1 S2 to S20				* cable + hyper- band: S01 to S1 S2 to S20 S21 to S41

UV617 UV618	UV627 UV628	UV635 UV636	UVF10 UVF10A
C.C.I.R.: B,G,H	C.C.I.R.: L,L'	R.T.M.A.: M,N	C.C.I.R.: L,L'
E2 to C* E5 to E12 E21 to E69 46 to 110 111 to 300 470 to 860	02 to 04 05 to 10* L21 to L69 55 to 64 128 to 297 470 to 861	A2 to A6 A7 to A13* A14 to A69 55 to 115 121 to 277 283 to 403 409 to 801	A to E4 M4 to E12 E21 to E69 41 to 68 162 to 230 470 to 861
38,9 33,4 256 (UV618 only) + 12 V ± 10% + 0,8 to + 28 V + 9,2 to + 0,85 V 40 dB 6 dB	32,7 39,2 256 (UV628 only) + 12 V ± 10% + 0,8 to + 28 V + 9,2 to + 0,85 V 40 dB 6 dB	45,75 41,25 256 (UV636 only) + 12 V ± 10% + 0,8 to + 28 V + 9,2 to + 0,85 V 45 dB 6,5 dB	32,7 39,2 256 (UVF10A only) + 12 V ± 1 V + 0,5 to + 28 V + 8,25 to + 0,85 V 22 dB 6 dB
84 x 20 x 55 IEC yes	84 x 20 x 55 IEC yes	84 x 20 x 55 phono no	94 x 23,5 x 73 coaxial female, plug on cable no
235	247	259	271
* cable: S01 to S1 S2 to S20	* cable: C to Q	* cable: A-2 to A-1 A to I J to T U to W AA to RR SS to EEE 65 and 66	

SELECTION GUIDES

	V.H.F. TUNERS		U.H.F. TUNERS		
	ECL3082	V431	CB112	U341(LO)/MK2	U342(LO)
System	R.T.M.A.: M,N	R.T.M.A.: M,N	D2-MAC	C.C.I.R.: G,H,I,K	C.C.I.R.: G,H,I,K
Channels	A2 to A6 A7 to A13	A2 to A6 A7 to A13		E21 to E69	E21 to E69
Frequency ranges (MHz)	54 to 88 174 to 216	54 to 88 174 to 216	950 to 1750 *	470 to 860	470 to 860
I.F. frequency (MHz) picture	45,75	45,75	479,5	38,9 (G,H) 39,5 (I,K)	38,9 (G,H) 39,5 (I,K)
sound	41,25	41,25		33,4 (G,H) 33,5 (I,K)	33,4 (G,H) 33,5 (I,K)
Divider ratio	—	—	—	—	—
Supply voltage	+ 12 V ± 10%	+ 12 V ± 10%	+ 12 V ± 5%	+ 12 V ± 10%	+ 12 V ± 10%
Tuning voltage	+ 0,5 to + 28 V	+ 1 to + 28 V	+ 0,8 to + 28 V	+ 1 to + 28 V	+ 1 to + 28 V
A.G.C. voltage	+ 5 to + 3 V	+ 9,2 to + 0,85 V	—	+ 9,2 to + 1 V	+ 9,2 to + 1 V
Amplification, typical	27 dB	26 dB	—	23 dB	23 dB
Noise figure, typical	7 dB	5 dB	10 dB	6,5 dB	6,5 dB
Overall dimensions l x w x h (mm)	99 x 29 x 59	95 x 23 x 77	165 x 19 x 90	83 x 18 x 52	83 x 18 x 52
Aerial input plug	pin	phono	E or IEC	coaxial female plug	p.w. pin
Page	13	285	**	55	71

* Channels 1 to 40 according to WARC77.

** The data on this type will be issued separately.

U.H.F. TUNERS

U343/U344	U411/U412	U743/U744
C.C.I.R.: G,H,I,K E21 to E69	C.C.I.R.: G,H,I,K E21 to E69	C.C.I.R.: I E21 to E69
470 to 860	470 to 860	470 to 860
38,9 (G,H) 39,5 (I,K) 33,4 (G,H) 33,5 (I,K)	38,9 (G,H) 39,5 (I,K) 33,4 (G,H) 33,5 (I,K)	39,5 33,5
256 (U344 only)	256 or 64 (U412 only)	256 (U744 only)
+ 12 V \pm 10%	+ 12 V \pm 10%	+ 12 V \pm 10%
+ 1 to + 28 V	+ 1 to + 28 V	+ 1 to + 28 V
+ 9,2 to + 1 V	+ 9,2 to + 0,85 V	+ 9,2 to + 1 V
42 dB	25 dB	40 dB
6,5 dB	7 dB	6,5 dB
83 x 18 x 52 phono or IEC	94 x 23,5 x 60,5 phono or IEC	66 x 20 x 38 phono or IEC
85	97	109

SELECTION GUIDES

COAXIAL AERIAL INPUT ASSEMBLIES

With mains separation

Frequency range

40 to 890 MHz

Impedance

75 Ω asymmetrical

Input connector

meets the demands of IEC 169.2 and DIN 45325
(dia. 9,5 mm), and of SNIR (dia. 9,0 mm)

Safety requirements

IEC 65; approbation approvals have been received
or sought from BSI, DEMKO, EI, FEMKO, KEMA,
LCEE, NEMKO, SEMKO, SEV and VDE.

cable length mm	insertion loss		catalogue number	page
	at frequency MHz	dB		
90 145 250	40–700 700–890	$\leq 1,5$ ≤ 2	3122 127 01240 3122 127 03500* 3122 127 05900	303
–	40–890 50–230 470–850	≤ 1 ≤ 1 ≤ 1	3122 127 10260 3122 127 10450	307
–	50–230 470 850	≤ 1 ≤ 1 $\leq 1,5$	3122 127 14730	307
–	40–300 470–890	≤ 1 ≤ 1	3122 127 21300**	313
–	40–230 230–300 470–890	≤ 1 $\leq 1,5$ $\leq 1,5$	3122 127 24140	317

* These assemblies comply with the requirements of immunity from radiated interference of
Amtsblatt DBP69/1981.

** This assembly complies with the requirements of immunity from radiated interference of BS905.

Pin Compatibility

All tuners of our 600-series and 700-series, and the tuner parts of our 600-series front-ends are pin-compatible, i.e. the pins for the same function are situated at the same place. However, the position of the mounting tab at the aerial input side of the tuners in the 700-series (MT4) is different, because these tuners are smaller. For this reason these tuners are also available with a longer aerial connector for interchangeability purposes. The front-ends have an extra mounting tab (MT3).

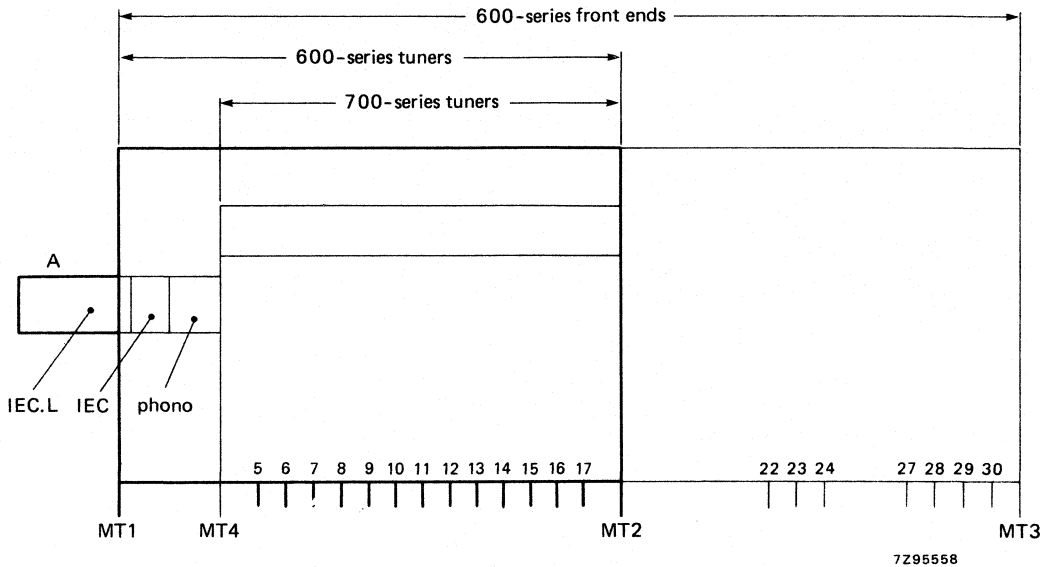

Fig. 6.

Terminal

- A = aerial input connector
 - 5 = a.g.c. voltage
 - 6 = supply voltage, + 12 V
 - 7 = supply voltage, low v.h.f., + 12 V
 - 8 = supply voltage, high v.h.f., + 12 V
 - 9 = supply voltage, hyperband, + 12 V
 - 10 = supply voltage, u.h.f., + 12 V
 - 11 = tuning voltage
 - 12 = supply voltage, frequency divider, + 5 V
 - 13, 14 = balanced output voltage of frequency divider
 - 15 = earth
 - 16 = i.f. output
 - 17 = i.f. output
- } (UV tuners)

Mounting tabs

- | | |
|-----------------------|---------------|
| 600-series tuners | MT1, MT2 |
| 700-series tuners | MT4, MT2 |
| 600-series front ends | MT1, MT2, MT3 |

TELEVISION TUNERS

V.H.F. TELEVISION TUNER

QUICK REFERENCE DATA

Systems	C.C.I.R. systems M and N (R.T.M.A.)
Channels	A2 to A6 (low v.h.f. band) A7 to A13 (high v.h.f. band)
Intermediate frequencies	
picture	45,75 MHz
sound	41,25 MHz

APPLICATION

Designed to cover the v.h.f. channels of C.C.I.R. systems M and N (R.T.M.A.).
Thanks to its good signal-handling properties, the tuner is especially suited for strong signal areas.

DESCRIPTION

The ELC3082 is a v.h.f. tuner with electronic tuning and band switching, covering the low v.h.f. band (frequency range 54 to 88 MHz) and the high v.h.f. band (frequency range 174 to 216 MHz).

Mechanically, the tuner is built on a low-loss printed-wiring board, carrying all components, in a metal housing made of a rectangular frame and front and rear covers (see Fig. 2). The aerial connection is on one of the frame sides, all other connections (supply voltages, a.g.c. voltage, tuning and switching voltages) are made via terminals in the under side. The mounting method is shown in Figs 3 and 4.

Electrically, the tuner consists of v.h.f. and i.f. parts. The aerial signal is fed to the input filters, providing i.f. rejection and band selection. The filters are followed by a P-I-N diode attenuator, equipped with two diodes BA379. The output of the attenuator is connected to the emitter of the input transistor BF480, operating as r.f. amplifier in grounded base configuration. The same transistor also delivers the current drive for the P-I-N diode attenuator, controlled by an a.g.c. voltage fed to the transistor base. The combination of the diode attenuator with this high current transistor (I_E at normal gain about 10 mA) has excellent signal-handling properties within the whole a.g.c. range.

The collector load of the input transistor is formed by a double tuned circuit, transferring the signal to the emitter of the mixer transistor BF324. Good signal-handling properties of this stage are achieved by high oscillator injection. The oscillator is equipped with a transistor BF324. In the low v.h.f. position, self-detection of the oscillator signal is used to back-bias the five switching diodes BA482/483/484, required for band switching between low and high v.h.f. channels. Three capacitance diodes BB809 provide tuning of the r.f. circuits. The collector of the mixer transistor is connected to a single tuned i.f. resonant circuit (about 20 MHz bandwidth), the output of which is fed to the i.f. output stage, equipped with another transistor BF324 in grounded base configuration. This stage has also been designed especially for good signal-handling properties. The collector load of the i.f. output transistor is formed by a single tuned i.f. circuit, at the low end of which the i.f. signal is capacitively coupled out of the tuner.

The tuner can be used in combination with a u.h.f. tuner. In this case the u.h.f. i.f. signal is fed to the emitter of the i.f. output transistor, which acts as i.f. amplifier for u.h.f. as well as for v.h.f.

The u.h.f. i.f. input terminal can be used as an i.f. injection point for aligning the i.f. output circuit together with the i.f. amplifier of the television receiver. For the same purpose a separate i.f. injection point has been provided at the collector of the mixer.

The tuner requires transistor supply voltages of +12 V, a switching voltage of +12 V, a.g.c. voltages, variable from +5 V (normal operating point) to about +2,5 V (maximum a.g.c.) and a tuning voltage, variable from +0,5 V to +28 V.

The aerial input of the tuner is asymmetrical. For use in symmetrical aerial systems, aerial transformers (baluns) are available (see ACCESSORY).

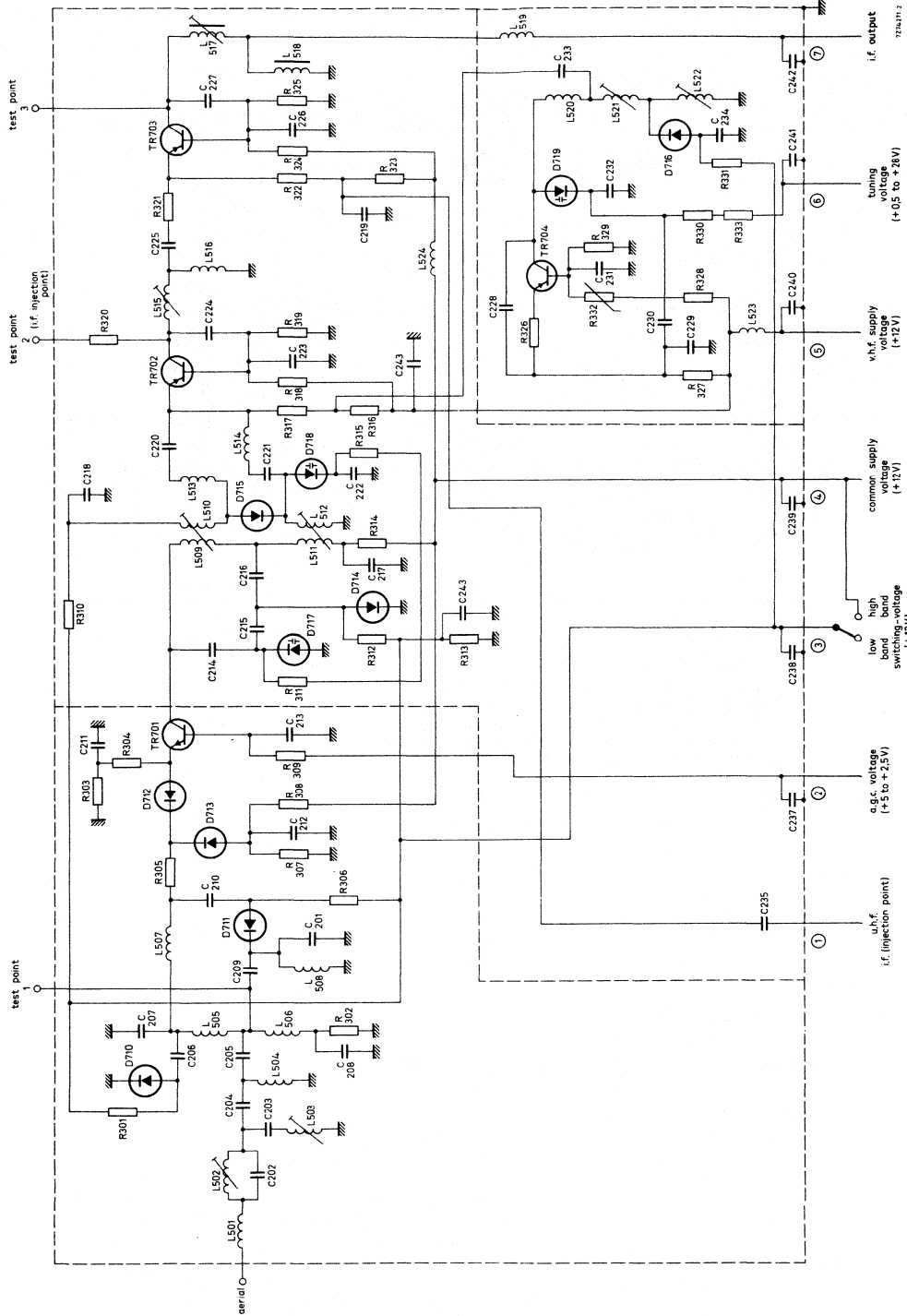

Fig. 1.

MECHANICAL DATA

Dimensions in mm

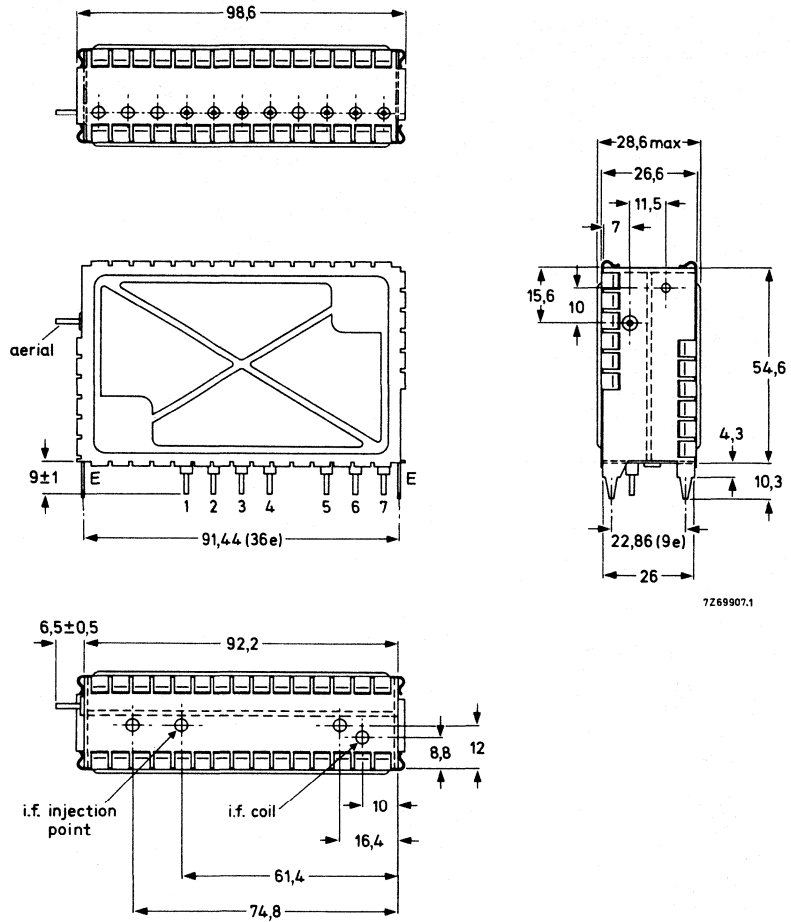

Fig. 2.

- Terminal 1 = u.h.f. i.f. input
- 2 = a.g.c. voltage, +5 to +2,5 V
- 3 = switching voltage, +12 V
- 4 = common supply voltage, +12 V
- 5 = v.h.f. supply voltage, +12 V
- 6 = tuning voltage, +0,5 to +28 V
- 7 = i.f. output
- E = earth

Mounting

The tuner may be mounted by soldering it on to a printed-wiring board, using the piercing diagram shown in Fig. 3. (The tuner may also be mounted by means of a bracket. Information will be supplied upon request.)

The tuner may be mounted anywhere in the receiver and there are no restrictions on orientation.

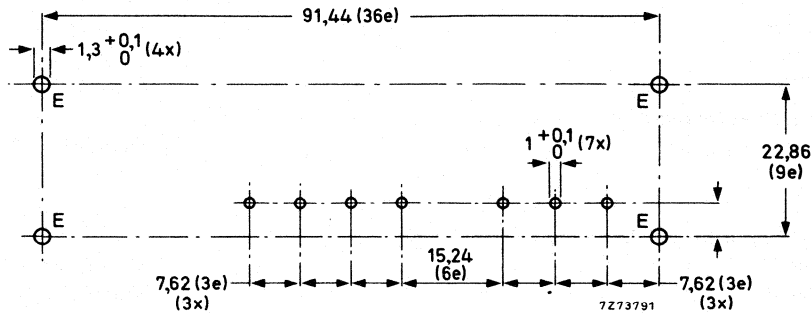

Fig. 3 Piercing diagram viewed from solder side of board: e = 2,54 mm (0,1 in).

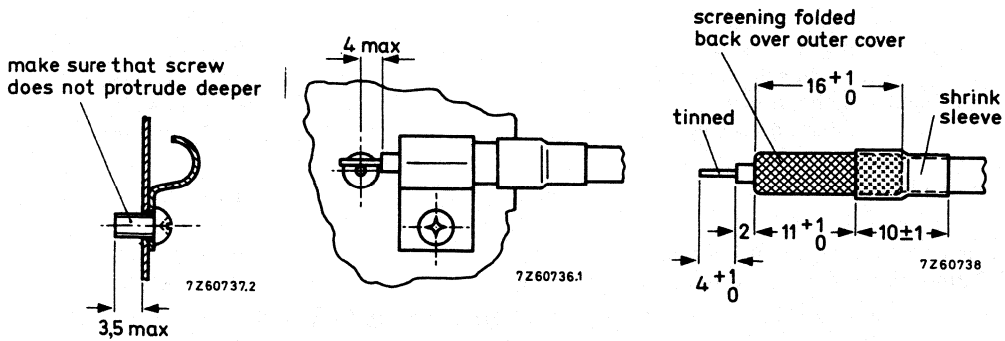

Fig. 4 Recommended fixing method of the aerial cable. Use a self-tapping screw.

ELECTRICAL DATA

Unless otherwise specified all electrical values apply at an ambient temperature of 25 ± 5 °C and a supply voltage of $12 \pm 0,3$ V.

Semiconductors

P-I-N attenuator	2 x BA379
r.f. amplifier	BF480
mixer	BF324
oscillator	BF324
tuning diodes	3 x BB809
switching diodes	5 x BA482/483/484
i.f. amplifier	BF324

Ambient temperature range

operating	+5 to +55 °C
storage	-25 to +85 °C

Supply voltage

+12 V \pm 10%

Current drawn from +12 V supply at nominal gain

low band	46,5 mA \pm 10%
high band	63,5 mA \pm 10%

Notes — At 40 dB gain reduction the currents decrease about 5 mA.

- The supply voltage at terminal 4 should be carefully filtered to avoid hum modulation in one of the P-I-N diodes when the attenuator is biased to higher attenuation ratios. Under most unfavourable conditions a ripple voltage of 3 mV (p-p) may produce a disturbance which is just visible.

A.G.C. voltage (Figs 5 and 6)

low band, at nominal gain	+5 \pm 0,2 V *
at 40 dB gain reduction	+3,3 V (typical)
high band, at nominal gain	+5 \pm 0,2 V *
at 40 dB gain reduction	+3,3 V (typical)

A.G.C. current

at nominal gain	max. 1 mA
with a.g.c.	max. 1 mA

Tuning voltage range (Figs 7 and 8)

+0,5 to +28 V

Current drawn from 28 V tuning voltage supply

max. 0,5 μ A

Note — The source impedance of the tuning voltage, offered to terminal 6, must be max. 100 k Ω at tuning voltages below 5 V.

Switching voltage

low band	open circuit
high band	+12 V \pm 10%

Note — In the low band position the tuner produces a negative voltage (1 to 5 V) at terminal 3; this terminal must not be loaded with an external resistance below 50 M Ω .

* This value may be increased to 5,5 V if a certain deterioration of signal handling is accepted. At voltages above 5,5 V the cross-modulation in band may deteriorate rapidly.

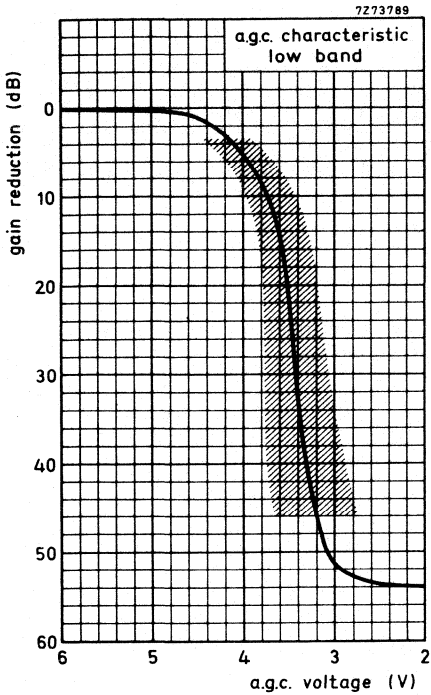

Fig. 5.

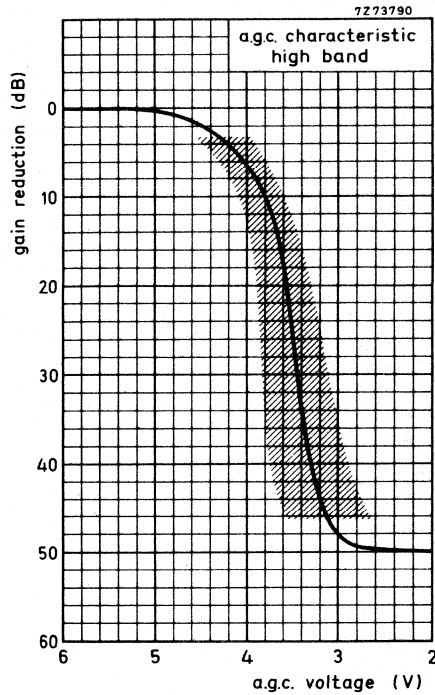

Fig. 6.

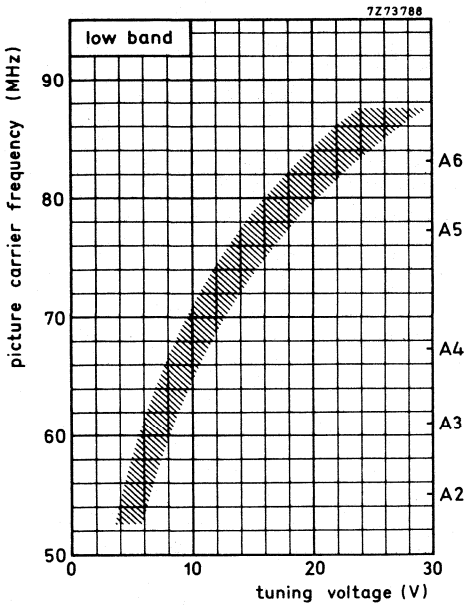

Fig. 7.

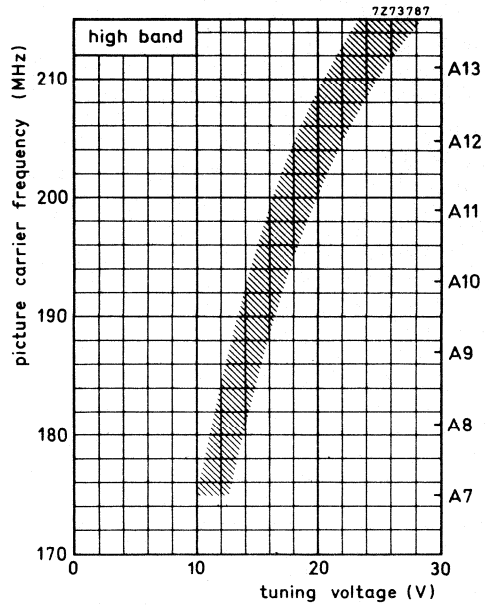

Fig. 8.

Frequency ranges			
low band		channel A2 (picture carrier 55,25 MHz)	
		to channel A6 (picture carrier 83,25 MHz).	
		Margin at the extreme channels: min. 2 MHz.	
high band		channel A7 (picture carrier 175,25 MHz)	
		to channel A13 (picture carrier 211,25 MHz).	
		Margin at the extreme channels: min. 3 MHz.	
Intermediate frequencies			
picture		45,75 MHz	
sound		41,25 MHz	
Input impedance, asymmetrical		75 Ω	
V.S.W.R. (between picture carrier and sound carrier)		v.s.w.r. at nom. gain	max. v.s.w.r. during gain control
low band		max. 3,5	max. 3,5
high band		max. 4	max. 4
A.G.C. range			
low band		min. 40 dB (typ. 54 dB)	
high band		min. 40 dB (typ. 50 dB)	
R.F. curves			
bandwidth, low band		typ. 7 to 10 MHz	
high band		typ. 8 to 10 MHz	
tilt, low band		max. 3 dB	
high band		max. 3 dB	
Power gain (see also MEASURING METHOD OF POWER GAIN)			
low band		min. 24 dB	
channel A2		typ. 27 dB	
channel A6		typ. 29 dB	
high band		min. 25 dB	
channel A7		typ. 28 dB	
channel A13		typ. 31 dB	
Noise figure			
low band		max. 9,5 dB (typ. 7 dB)	
high band		max. 9,5 dB (typ. 7,5 dB)	
I.F. rejection			
low band, channel A2		min. 54 dB	
channel A3		min. 57 dB	
channels A4 to A6		min. 60 dB	
high band		min. 60 dB	

Image rejection		
low band	min. 56 dB	
high band	min. 50 dB	
Signal handling		
Minimum input signal (e.m.f.) producing cross-modulation (1%)		
in channel	max. gain	with a.g.c.
wanted signal: picture carrier frequency,		
interfering signal: sound carrier frequency	typ. 20 mV	typ. > 500 mV
in band		
wanted signal: picture carrier frequency		
of channel N.	typ. 100 mV	typ. > 500 mV
interfering signal: picture carrier of		
channel $N \pm 2$	typ. 250 mV	typ. > 500 mV
interfering signal: picture carrier of		
channel $\geq N \pm 3$		
Minimum input signal (e.m.f.) producing overloading,		
at nominal gain	typ. 50 mV	} **
at maximum a.g.c.	typ. > 500 mV	
Minimum input signal (e.m.f.) at nominal gain producing a shift of the oscillator frequency of 10 kHz,		
low band	typ. 50 mV	} ▲
high band	typ. 30 mV	
Detuning of the i.f. output circuit as a result of band switching and tuning	max. 150 kHz	
Shift of oscillator frequency at a change of the supply voltage of 5%		
low band	max. 300 kHz	
high band	max. 300 kHz	
during warm-up time (measured between 5 s and 15 min after switching on)		
low band	max. 150 kHz	
high band	max. 150 kHz	

* This e.m.f. (open voltage) is referred to an impedance of 75 Ω .
 1% cross-modulation means that 1% of the modulation depth of the interfering signal is transferred to the wanted signal.

** This e.m.f. (open voltage) is referred to an impedance of 75 Ω .
 Criterion of overloading: 30% compression of the synchronization pulses of a standard television signal or a noticeable deterioration of the picture quality.

▲ This e.m.f. (open voltage) is referred to an impedance of 75 Ω .

Drift of oscillator frequency

at a change of the ambient temperature from 25 to 50 °C
25 to 50 °C

low band

max. 500 kHz

high band

max. 500 kHz

Oscillator radiation

The tuner is in conformity with the radiation requirements of C.I.S.P.R. Recommendation No. 24/2 and the corresponding F.C.C. rules , provided the tuner is installed in a professional manner.

Microphonics

If the tuner is installed in a professional manner, there will be no microphonics.

Surge protection

Protection against voltages max. 5 kV

Note: Three discharges of a 470 pF capacitor into the aerial terminal.

ALIGNMENT OF THE I.F. CIRCUIT

For i.f. injection the u.h.f. i.f. input (terminal 1) or the i.f. injection point at the collector of the mixer transistor (at the top of the tuner, Fig. 2) can be used.

The aligning can be done with any channel tuned. A probe as shown in Fig. 9 should be used.

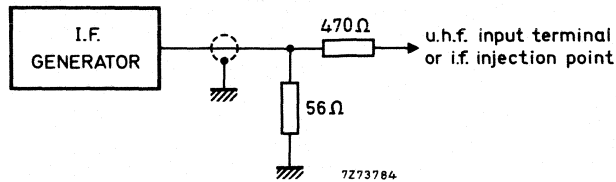

Fig. 9.

The signal attenuation between the i.f. generator and the i.f. output of the tuner is about 4 dB when injection is done via the injection point, and about 8,5 dB in the case of injection via the u.h.f. i.f. input.

The i.f. output circuit is detuned about +300 kHz* or -150 kHz* when injection is done via the injection point or via the u.h.f. i.f. input respectively.

MEASURING METHOD OF POWER GAIN

The i.f. output of the tuner should be terminated with the RC-circuit given in Fig. 10.

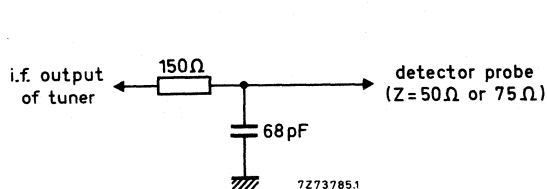

Fig. 10.

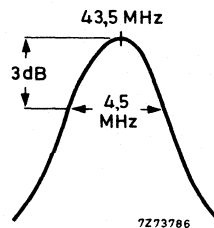

Fig. 11.

The RC-circuit roughly matches the i.f. output impedance to 75 Ω at the resonant frequency of the i.f. output circuit, which should be tuned to 43,5 MHz. The bandwidth should be approx. 4,5 MHz.

Because the input and output impedances of the tuner are now 75 Ω, the power gain can be measured in the conventional manner by inserting tuner and RC-circuit between a 75 Ω source and a 75 Ω detector (or between a 50 Ω source and matching pad 50/75 Ω and a 50 Ω detector).

* Reference: normal operation with r.f. signal via aerial input.

V.H.F./U.H.F. TELEVISION TUNER AND I.F. DEMODULATOR

QUICK REFERENCE DATA

Systems	C.C.I.R. systems B, G and H	
Channels	off-air	cable
low v.h.f.	E2 to C	S01 to S1
high v.h.f.	E5 to E12	S2 to S20
u.h.f.	E21 to E69	
Intermediate frequencies		
picture	38,90 MHz	
colour	34,47 MHz	
sound 1	33,40 MHz	
sound 2	33,16 MHz	
Video output signal		
peak-to-peak voltage	2,1 to 2,8 V	
top sync level	2,2 to 2,6 V ←	
Intercarrier sound output signals		
5,50 MHz	200 to 500 mV r.m.s.	
5,74 MHz	90 to 225 mV r.m.s.	

APPLICATION

Designed to cover the tuner function according to the C.C.I.R. systems B, G and H with extended v.h.f. frequency ranges, combined with a quasi split sound i.f. function to demodulate the video signal and to convert the sound signal.

The tuner part of the FE618Q(M)/256 is equipped with a frequency divider, which makes it suitable for digital tuning systems based on frequency synthesis; for the remainder it is equal to type FE617Q(M).

Available versions

	aerial input connector	frequency divider (IC)	catalogue number
FE617Q	IEC		t.b.f.
FE617QM	IEC		3122 237 10170
FE618Q/256	IEC	1:256	3122 237 10030
FE618QM/256	IEC	1:256	3122 237 10020

These types comply with the requirements of radiation, signal handling capability, and immunity from radiated interference of Amtsblatt DBP69/1961, and for Finland E.I.S. bulletin T33-82, section 4, when installed professionally in an adequate TV receiver.

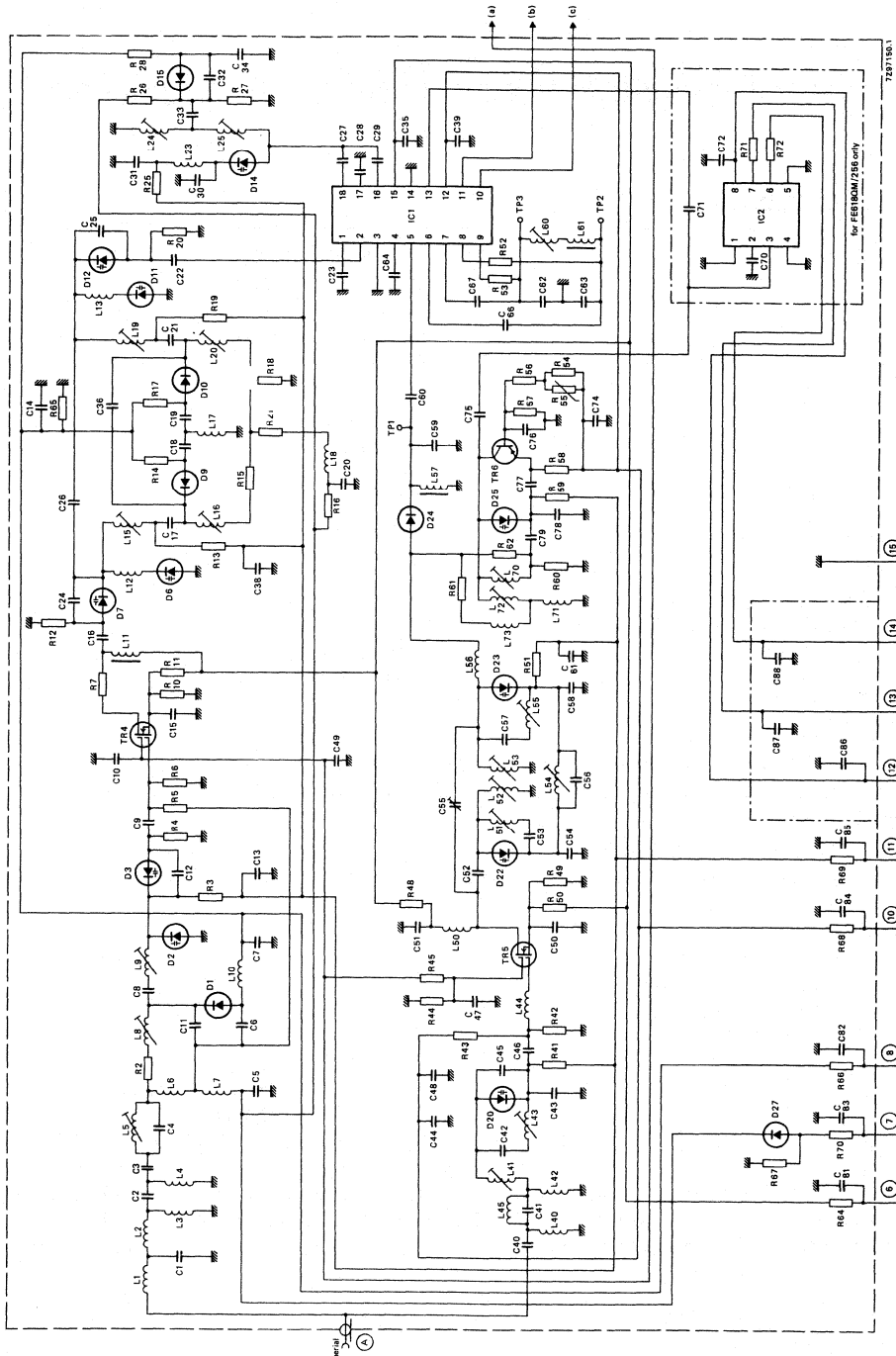
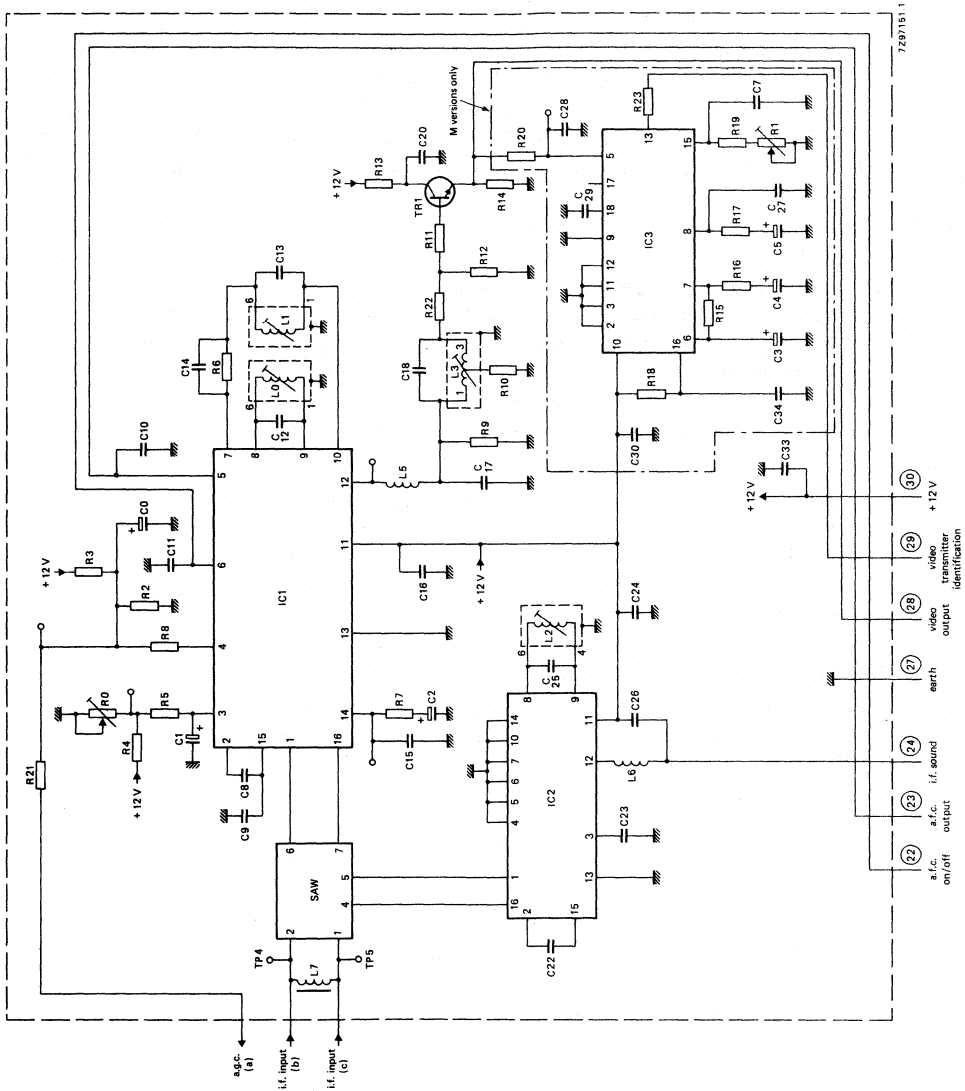

Fig. 1 Tuner part.
 For types FE617Q and QM delete: C71, C72, C86, C87, C88, R71, R72, IC2.
 For connections see Fig. 3.



For connections see Fig. 3.

DESCRIPTION

The front ends contain v.h.f./u.h.f. tuners with electronic tuning and band switching, covering the low v.h.f. band (frequency range 46 to 110 MHz), the high v.h.f. band (frequency range 111 to 300 MHz), and the u.h.f. band (frequency range 470 to 860 MHz).

→ Mechanically, the front ends consist of a tuner part and an i.f. part built on separate low-loss printed-wiring boards, carrying all components, in a housing made of a rectangular diecast metal frame and front and rear covers (see Fig. 3). The common IEC coaxial aerial connector (75 Ω) is integrated in one of the frame sides of the housing, all other connections (supply voltages, a.g.c. voltage, tuning and switching voltages, i.f. output) are made via terminals in the underside. The mounting method is shown in Fig. 4.

Electrically, the tuner part consists of v.h.f. and u.h.f. parts (see Fig. 1). They are equipped with a common aerial input and provided with r.f. MOSFET input stages. The v.h.f. mixer, v.h.f. oscillator and i.f. amplifier functions are provided by a tuner IC. This IC has terminals between mixer and i.f. amplifier to connect the i.f. preselection.

The r.f. band pass filter and oscillator circuits are tuned by 7 tuning diodes; band switching is achieved by 4 switching diodes.

The u.h.f. part of the tuner has a high-pass input circuit connected to gate 1 of an input MOSFET tetrode (with internal gate protection against surge). The drain load of this MOSFET tetrode is formed by a double tuned circuit transferring the r.f. signal to the Schottky barrier mixer diode. The i.f. signal from the mixer diode is amplified by the i.f. pre-amplifier of the tuner I.C.

The r.f. band pass filter and oscillator circuits are tuned by 4 tuning diodes.

In all bands the tuner is gain-controlled via gate 2 of the input MOSFET tetrode.

A test point TP1 is provided for i.f. injection.

The electrical circuit of the FE618Q(M)256 is extended with a frequency divider (division ratio of 256), with inputs connected to the v.h.f. and u.h.f. oscillators. The symmetrical ECL outputs are connected to terminals 13 and 14.

The i.f. part is of the quasi-split sound type. It has separate ICs for video demodulation and sound conversion (see Fig. 2).

→ The demodulated (CVBS-) video signal is available at the video output of the front end and the converted sound signal, with intercarrier frequencies of 5,50 MHz and 5,74 MHz, is available at the sound output.

→ In the i.f. part of the QM versions a video identification signal is also generated. This can be used to mute the sound in case of "no video" and is available at the video identification output.

Terminal designations in Fig. 3

A	= aerial input (IEC female 75 Ω)		15 = earth
6	= supply voltage, tuning part, + 12 V		22 = switching voltage a.f.c.
7	= supply voltage, low v.h.f., + 12 V		23 = a.f.c. output
8	= supply voltage, high v.h.f., + 12 V		24 = i.f. sound
10	= supply voltage, u.h.f., + 12 V		27 = earth
11	= tuning voltage, + 0,48 to + 28 V		28 = video output
12	= supply voltage, frequency divider, + 5 V	} only for FE618Q/256 and FE618QM/256	29 = video identification output, QM versions only
13, 14	= balanced output voltage of frequency divider (1 kΩ)		30 = supply voltage, i.f., demodulation part, + 12 V

MECHANICAL DATA

Dimensions in mm

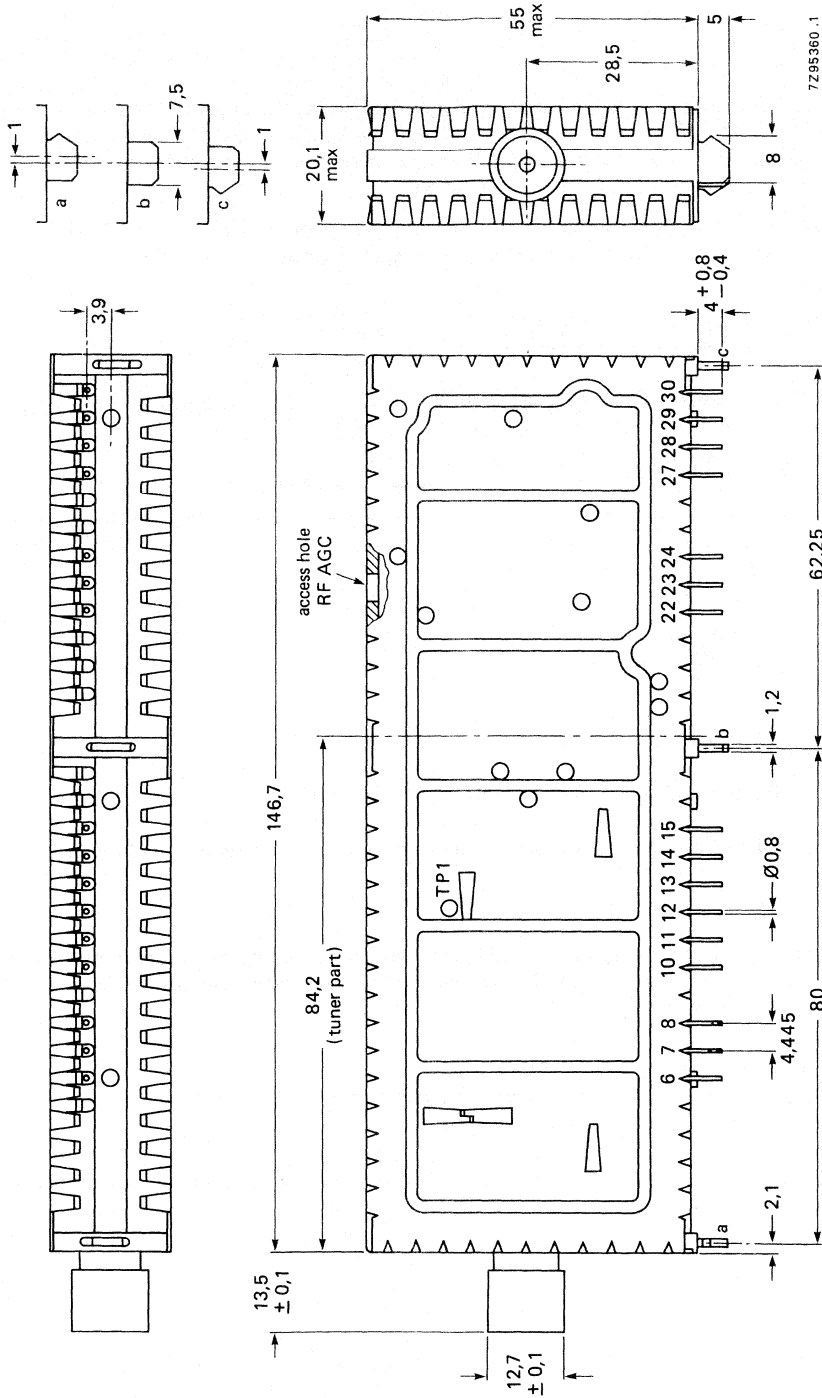

7295360.1

Fig. 3 Unless otherwise stated the tolerance is ± 0.05 mm.

Mass approx. 160 g

Mounting

The unit may be mounted by soldering it on to a printed-wiring board (using the piercing diagram shown in Fig. 4). The construction and positioning of the 3 mounting tags is such that a 'click' indicates the correct seating of the unit on the printed-wiring board. The unit may be mounted anywhere in the receiver and there are no restrictions on orientation.

The solderability of the terminals and mounting tags is according to IEC 68-2, test Ta ($235 \pm 5 \text{ }^\circ\text{C}$, $2 \pm 0,5 \text{ s}$). The resistance to soldering heat is according to IEC 68-2, test Tb ($260 \pm 5 \text{ }^\circ\text{C}$, $10 \pm 1 \text{ s}$).

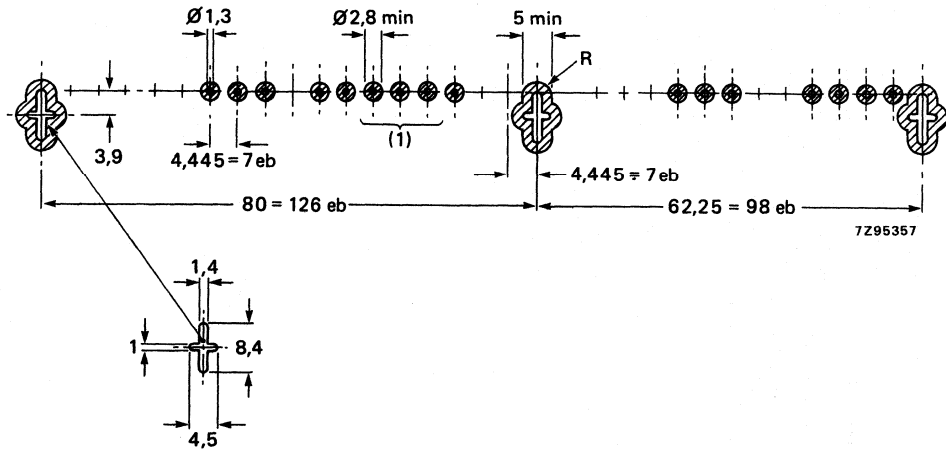

(1) Only for FE618Q/256 and FE618QM/256 1 eb = 0,025 inch

Fig. 4 Piercing diagram viewed from solder side of board. Unless otherwise stated the tolerance is $\pm 0,05 \text{ mm}$.

In order to withstand vibrations, shocks and bumps that could damage the solder joints of the mounting tags, the front end should be mounted and soldered without clearance between the supporting area and the printed-wiring board.

This can be achieved by:

- twisting the mounting tags 18° (-3°); or
- pressing the front end against the printed-wiring board during soldering; or
- supporting the front end at its aerial connector.

If the aerial connector is used as a direct input to the television set, it should be supported to prevent the printed-wiring board from stress.

ELECTRICAL DATA

Unless otherwise specified all electrical values apply at an ambient temperature of 25 ± 5 °C, a relative humidity of $60 \pm 15\%$, supply and band switching voltages of $12 \pm 0,3$ V.

General**Semiconductors, v.h.f. bands**

r.f. amplifier	BF992	
mixer	TDA5030	
oscillator		
tuning diodes	7 x BB909	←
switching diodes	4 x BA482/483/484	
d.c. blocking diodes	2 x BAS15	

Semiconductors, u.h.f. bands

r.f. amplifier	BF990	
oscillator	BF970	
mixer	1SS99	
tuning diodes	4 x BB405	←

Frequency divider

SP4653

Semiconductors, i.f.

i.f. amplifier and demodulator	TDA2541
quasi-split-sound circuit	TDA2545A
synchronization circuit	TDA2577A
video output transistor	BC548

S.A.W. filter

OFW G3203

Ambient temperature range

operating	-10 to + 60 °C
storage	-25 to + 85 °C

Relative humidity

max. 95%

Voltages and currents**Supply voltages (tuner and i.f. part)**+ 12 V \pm 10%**Current drawn from + 12 V supply**

v.h.f. bands	max. 50 mA
u.h.f. bands	max. 45 mA
bandswitching	max. 15 mA
i.f. part	max. 200 mA, without mute 140 mA

For operation in all bands the terminals 6 and 30 are permanently connected to their voltage supplies. Additionally the supply voltage for band switching is connected to:

- terminal 7 for operation in low v.h.f. band
- terminal 8 for operation in high v.h.f. band
- terminal 10 for operation in u.h.f. bands

Tuning voltage range	+ 0,8 to + 28 V
Current drawn from 28 V tuning voltage supply	
at $T_{amb} = 25\text{ }^{\circ}\text{C}$ and 60% R.H.	max. 0,5 μA
at $T_{amb} = 25\text{ }^{\circ}\text{C}$ and 95% R.H.	max. 2 μA
at $T_{amb} = 60\text{ }^{\circ}\text{C}$ and 60% R.H.	max. 2 μA

Note: The source impedance of the tuning voltage offered to terminal 11 must be maximum 47 k Ω .

Aerial input characteristics

Input impedance	75 Ω
V.S.W.R. and reflection coefficient (values between picture and sound carrier, as well as values at picture carrier)	
v.s.w.r.	<u>at nominal gain and during gain control</u>
v.h.f. bands	max. 4
u.h.f. bands	max. 5
reflection coefficient	
v.h.f. bands	max. 60%
u.h.f. bands	max. 66%
Gain limited sensitivity level	
v.h.f. C.C.I.R. channels and u.h.f. channels	typ. 25 dB (μV), max. 33 dB (μV)
S-channels	typ. 29 dB (μV), max. 37 dB (μV)
A.G.C. limited aerial input level	
v.h.f. bands	min. 100 dB (μV)
u.h.f. bands	min. 90 dB (μV)
Oscillator voltage level (fundamental and harmonics up to 1000 MHz) at the input	
v.h.f. bands	max. 44 dB (μV)
u.h.f. bands	max. 66 dB (μV)
Surge protection	max. 5 kV

Tuning characteristics

Frequency ranges	
low v.h.f. band	channel E2 (picture carrier 48,25 MHz) to channel S1 (picture carrier 105,25 MHz).
high v.h.f. band	channel S2 (picture carrier 112,25 MHz) to channel S20 (picture carrier 294,25 MHz).
u.h.f. bands	channel E21 (picture carrier 471,25 MHz) to channel E69 (picture carrier 855,25 MHz).

The frequency ranges remain valid under the specified operating conditions during the entire life time of the unit.

The oscillator frequency is higher than the aerial signal frequency.

Slope of tuning characteristic		
low v.h.f. band, channel E2	5 MHz/V	} typical values ←
channel S1	1 MHz/V	
high v.h.f. band, channel S2	10 MHz/V	
channel S20	2 MHz/V	
u.h.f. bands, channel E21	22 MHz/V	
channel E69	5 MHz/V	
Tuning voltage range within which the divided oscillator frequency increases monotone with the tuning voltage (FE618 versions only)		0,45 to 30 V ←
Slope of tuning characteristic		
low v.h.f. band	1 to 6 MHz/V	
high v.h.f. band	2 to 14 MHz/V	
u.h.f. bands	4 to 25 MHz/V	
Tuning voltage range within which the tuning frequency increases monotone with the tuning voltage		0,45 to 30 V
Time constant of varicap voltage		1,5 ms
Aerial input level causing detuning of -300 or + 1000 kHz		
v.h.f. bands		min. 100 dB (μV)
u.h.f. bands		min. 90 dB (μV)
Oscillator characteristics		
Shift of oscillator frequency at a change of the supply voltage of 5%		
v.h.f. bands		max. 250 kHz
u.h.f. bands		max. 500 kHz
Drift of oscillator frequency		
during warm-up time (after the tuner has been completely out of operation for 15 min, measured between 5 s and 15 min after switching on)		max. 250 kHz
during warm-up time (after the input stage is in operation for 15 min, measured between 2 s and 15 min after band switching)		max. 250 kHz
at a change of the ambient temperature from + 25 to + 50 °C and from + 25 to + 0 °C		
v.h.f. bands		max. 500 kHz
u.h.f. bands		max. 1000 kHz
at a change of humidity from 60 ± 15% to 93 ± 2%, at T _{amb} = 25 ± 5 °C		
low v.h.f. band		max. 500 kHz
high v.h.f. band		max. 1000 kHz
u.h.f. bands		max. 1500 kHz

Frequency divider characteristics (FE618Q/256 and FE618QM/256 only)

Supply voltage	+ 5 V ± 5%
Current drawn from + 5 V supply	max. 35 mA; typ. 25 mA
Output voltage, unloaded, measured with probe 10 MΩ/11 pF	min. 0,5 V(p-p)
Output impedance	typ. 1 kΩ
Output imbalance	max. 0,1 V

A.F.C. output characteristics

Output capacitance	typ. 1,2 nF
Output voltage, when loaded with 25 kΩ	
A.F.C. switched off	6 V
A.F.C. switched on	
voltage for an aerial input of 50 dB (μV)	
correctly tuned	6 V
detuning of + 100 kHz	max. 1,5 V
detuning of -100 kHz	min. 10,5 V
A.F.C. output slope at $V_{afc} = 6 V$ and $V_{aerial} = 50 dB (\mu V)$	min. 50 V/MHz, max. 150 V/MHz
A.F.C. voltage when no aerial input	min. 3 V, max. 8 V

Video output characteristics

Measuring conditions: video output (terminal 28) loaded with 155 Ω, decoupling of i.f. supply (terminal 30) with 220 μF.

Video peak-to-peak voltage, video modulation 100%, rest carrier 10%

→ Top sync level	min. 2,1 V, max. 2,8 V
No-signal level	min. 2,2 V, max. 2,6 V
	min. 5,0 V, max. 5,7 V

Video signal expansion for a change of the aerial input signal level from 40 dB (μV) to 90 dB (μV)

max. 0,5 dB

Unweighted video signal to noise ratio for an aerial input level of 50 dB (μV)

v.h.f. C.C.I.R. channels	typ. 36 dB, min. 33 dB
S-channels	typ. 34 dB, min. 31 dB
u.h.f. channels	typ. 32 dB, min. 29 dB

Unweighted video S/N-ratio for $V_{\text{aerial}} = 70 \text{ dB } (\mu\text{V})$		
v.h.f. C.C.I.R.-channels	typ. 46 dB	
S-channels	typ. 44 dB	
u.h.f. channels	typ. 46 dB	
Flatness (0,1 – 3,5 MHz)		
v.h.f./u.h.f. for V_{aerial} up to 70 dB (μV)	max. 3 dB	
v.h.f. for $V_{\text{aerial}} = 100 \text{ dB } (\mu\text{V})$	max. 4 dB	
u.h.f. for $V_{\text{aerial}} = 90 \text{ dB } (\mu\text{V})$	max. 4 dB	
Group delay time deviation (0,1 – 3,5 MHz) for V_{aerial} up to 70 dB (μV)		
v.h.f., channels E3 and up; u.h.f. channels	max. 50 ns	
v.h.f., channel E2 minus 1 MHz	max. 60 ns	
Gain drop at colour carrier for $V_{\text{aerial}} = 70 \text{ dB } (\mu\text{V})$; 1 MHz reference		
at 4,43 MHz	typ. 5 dB	max. 8,5 dB
at 4,00 MHz	typ. 2 dB	
at 4,80 MHz	typ. 11 dB	←
Group delay time deviation at colour carrier frequency (4,43 MHz)	typ. 60 ns	
2T-impulse response		
top level referred to black-white response	typ. 105%	min. 85% max. 125%
50% level width	min. 180 ns	max. 220 ns
K-rating	max. 4%	
Differential gain	typ. 4%	max. 10%
Differential phase	typ. 2°	max. 10°
Field time waveform distortion	max. 10%	
Line time waveform distortion	max. 10%	
1,07 MHz sound-chroma interference level conditions		
gain control	30 dB	←
picture carrier/colour carrier ratio	16 dB	
picture carrier/sound carrier ratio	10 dB	
40 dB interference distance at video output	typ. 90 dB (μV)	

FE617Q FE617QM
 FE618Q/256
 FE618QM/256

Sound carriers rejection			
5,48 MHz to 5,52 MHz	min.	50 dB	
5,74 MHz	min.	35 dB	
Level residual i.f. carrier and harmonics	max.	3,5 mV	
Frequency divider interference distance for $V_{\text{aerial}} = 50 \text{ dB } (\mu\text{V})$ (referred to 1 MHz)	min.	40 dB	
Image rejection for $V_{\text{aerial}} = 70 \text{ dB } (\mu\text{V})$			
v.h.f. bands	min.	66 dB	
u.h.f. bands	min.	53 dB	
First repeat spot interference aerial input level			
v.h.f. bands	min.	75 dB (μV)	
u.h.f. bands	min.	63 dB (μV)	
Unwanted aerial input level for 1% cross modulation at a wanted signal level of 50 dB (μV)			
$N \pm 1$ v.h.f.	min.	74 dB (μV)	
$N \pm 1$ u.h.f.	min.	74 dB (μV)	
In-band v.h.f.-low, $N \pm 2$	typ.	92 dB (μV)	
In-band v.h.f.-high, $N \pm 3$	typ.	92 dB (μV)	
In-band u.h.f., $N \pm 5$	typ.	100 dB (μV)	
Out-of-band	min.	100 dB (μV)	
→ Breakthroughs	typ.	80 dB (μV)	
Ripple susceptibility			
at pins 7, 8 and 10	min.	5 mV (p-p)	
at pins 6 and 30	min.	30 mV (p-p)	

Video identification (QM versions only)

Load impedance 100 k Ω

Output voltage (terminal 29)

no video

min. 10 V

video

max. 0,5 V

Line frequency for guaranteed

video identification

min. 15,0 kHz; max. 16,2 kHz

Aerial input sensitivity level

typ. 25 dB (μ V)



Sound carrier output characteristics

Measuring conditions:

Sound output load impedance (via d.c. block capacitor)

3 k Ω

Sound carrier levels related to picture carrier level:

first sound carrier (5,50 MHz)

typ. -13 dB

second sound carrier (5,74 MHz)

typ. -20 dB

Nominal r.m.s. signal level

5,50 MHz

min. 200 mV; max. 500 mV

5,74 MHz

min. 90 mV; max. 225 mV

D.C. voltage level (terminal 24)

min. 4,8 V; max. 7 V

Signal to noise ratio weighted according to

C.C.I.R. 468-3, determined after f.m.-detection for

aerial input signal level 70 dB (μ V) and

video contents:

black, 5,50 MHz

typ. 50 dB

black, 5,74 MHz

typ. 55 dB

5 kHz sine wave, 5,50 MHz

min. 42 dB; typ. 50 dB

5 kHz sine wave, 5,74 MHz

min. 40 dB; typ. 50 dB

250 kHz sine wave, 5,50 MHz

min. 42 dB; typ. 50 dB

250 kHz sine wave, 5,74 MHz

min. 32 dB; typ. 34 dB



Miscellaneous

Radio interference
Oscillator radiation and oscillator
voltage at the aerial terminal



Within the limits of C.I.S.P.R. 13
(1975) + amendment 1 (1983),
VDE0872/7.72., Amtsblatt
DBP69/1981, and for Finland
E.I.S., bulletin T33-82, section 4,
when applying the unit in an
adequate TV receiver

Microphonics

There will be no microphonics,
provided the unit is installed
in a professional manner.

→ Surge protection of aerial input
against voltages

max. 5 kV

Note: 10 discharges of a 470 pF capacitor into the aerial terminal.

Protection against flashes

max. 30 kV, 400 mWs

Note: A flashover circuit producing flashes with frequencies of 1 to 20 Hz for 30 s is connected to the
aerial terminal.

V.H.F./U.H.F. TELEVISION TUNERS

QUICK REFERENCE DATA

Systems	R.T.M.A. systems M and N
Channels	
low v.h.f. band	A2 to A6
high v.h.f. band	A7 to A13
u.h.f. bands	A14 to A83
Intermediate frequencies	
picture	45,75 MHz
sound	41,25 MHz
colour	42,17 MHz

APPLICATION

Designed to cover the v.h.f. and u.h.f. channels of R.T.M.A. systems M and N.

The tuner is provided with a frequency divider (1 : 256 or 1 : 64), which makes it suitable for digital tuning systems based on frequency synthesis.

Available versions

tuner type	aerial input connector	frequency divider ratio	catalogue number
M33	phono	—	3122 127 09710
M34	phono	64	3122 127 09750
M34/256	phono	256	3122 237 00070

DESCRIPTION

The M34 is a combined v.h.f./u.h.f. tuner with electronic tuning and band switching, covering the low v.h.f. band (frequency range 54 to 88 MHz), the high v.h.f. band (frequency range 174 to 216 MHz), and the u.h.f. bands (frequency range 470 to 890 MHz).

Mechanically, the tuner is built on a low-loss printed-wiring board, carrying all components, in a metal housing made of a rectangular frame and front and rear covers (see Fig. 2). The common coaxial phono aerial connector (75Ω) is on one of the frame sides. The coaxial i.f. output is at the top. All other connections (supply voltages, a.g.c. voltage, tuning and switching voltages, prescaler outputs) are made via terminals in the underside. The mounting method is shown in Fig. 3.

Electrically, the tuner comprises v.h.f. and u.h.f. parts (see Fig. 1). The v.h.f. aerial signal is fed via switchable low and high v.h.f. tuned input filters to gate 1 of an input MOSFET tetrode (with internal gate protection against surge).

The input filters are provided with an i.f. and f.m. suppression circuit. The drain load of the MOSFET tetrode is formed by a double tuned switchable bandpass filter, transferring the r.f. signal to the emitter of the mixer transistor. The oscillator signal is also fed to the emitter of the mixer transistor.

The collector circuit of the mixer transistor is a single tuned i.f. resonant circuit. The i.f. signal is coupled out via an additional i.f. amplifier. A test point (T.P.) is provided for i.f. injection to align the i.f. output circuit of the tuner together with the i.f. amplifier of the television receiver.

The test point is accessible through a hole in the top of the tuner and is connected to the collector of the mixer transistor.

The single tuned input, the r.f. band pass filter and oscillator circuits are tuned by 4 tuning diodes; band switching is achieved by 5 switching diodes.

The u.h.f. part of the tuner consists of a single tuned input circuit connected to gate 1 of an input MOSFET tetrode (with internal gate protection against surge). The drain load of this MOSFET tetrode is formed by a double tuned circuit transferring the r.f. signal to the Schottky barrier mixer diode. The i.f. signal from the mixer diode is amplified by the v.h.f. mixer transistor, now operating as an i.f. amplifier.

The r.f. bandpass filter and oscillator circuits are tuned by 3 tuning diodes.

In all bands the tuner is gain-controlled via gate 2 of the input MOSFET tetrode.

The electrical circuit contains a frequency divider (division ratio 256 or 64), with inputs from the v.h.f. and u.h.f. oscillators. The complementary outputs are connected to terminals 12 and 13.

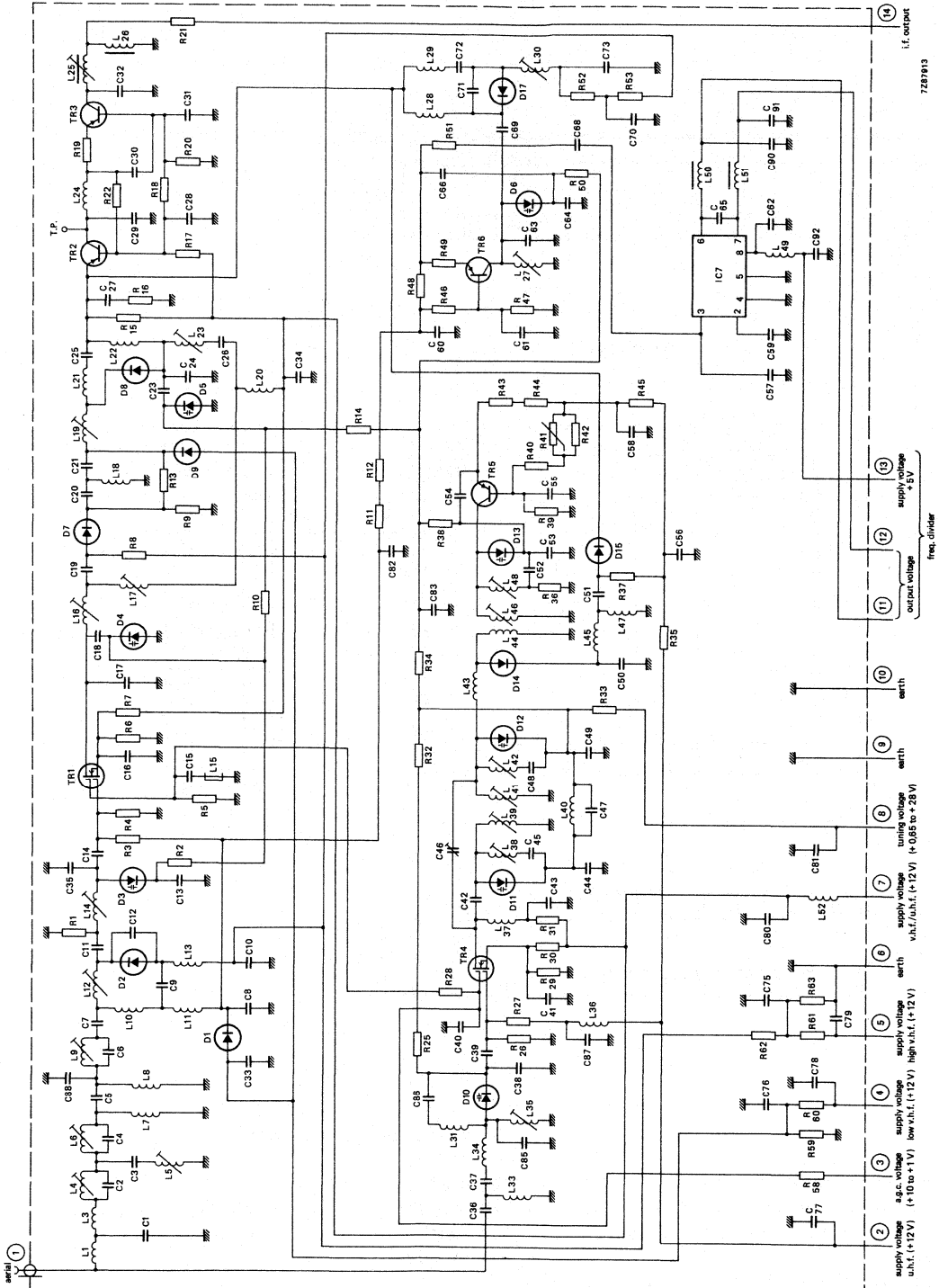

Fig. 1.

MECHANICAL DATA

Dimensions in mm

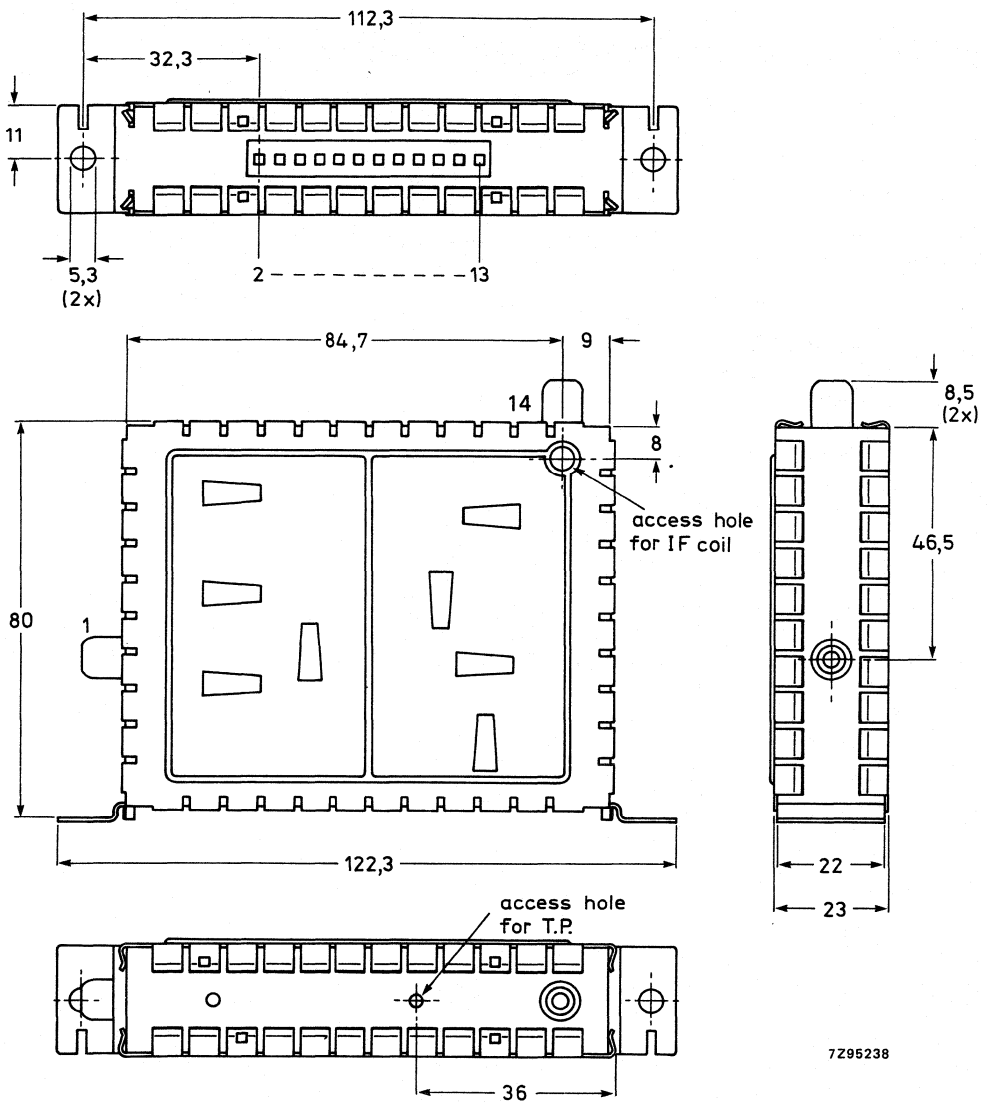

Fig. 2a.

Terminal

- 1 = aerial
- 2 = supply voltage, u.h.f., + 12 V
- 3 = a.g.c. voltage, + 10 to + 1 V
- 4 = supply voltage, low v.h.f., + 12 V
- 5 = supply voltage, high v.h.f., + 12 V
- 6 = earth
- 7 = supply voltage, v.h.f./u.h.f., + 12 V

- 8 = tuning voltage, 0,65 to 28 V
- 9 = earth
- 10 = earth
- 11, 12 = balanced output voltage of frequency divider
- 13 = supply voltage, frequency divider, + 5 V
- 14 = i.f. output

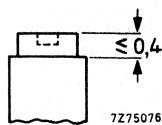

Fig. 2b I.F. output coil.
Torque for alignment: 2 to 20 mNm.
Press-through force: $\leq 10\text{N}$.

Mass approx. 125 g

Mounting

1,14 mm (0,045 in) square pins of the Molex 2161 series must be inserted in holes with a diameter of 1,5 mm in a printed-wiring board of which the piercing diagram is given in Fig. 3. Pins in holes marked A are to protect the tuner against reversed mounting. Height of the pins above the component side of the board should be 10 ± 1 mm.

The tuner can be mounted anywhere in the receiver and fixed by means of bolts and nuts, e.g. M5. There are no restrictions on orientation.

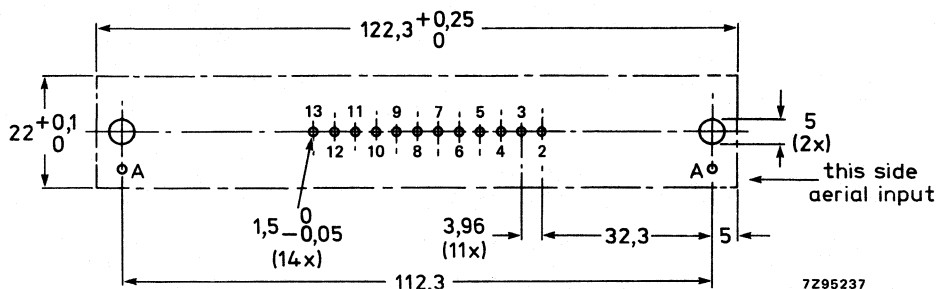

Fig. 3 Piercing diagram viewed from solder side of board.

Marking

The tuner is provided with a label, stuck on the top face, on which the following data are printed:

- type number M34
- catalogue number
- letter code for origin
- change code
- data code (year and week), a belt number can be added.

ELECTRICAL DATA

Unless otherwise specified all electrical values apply at an ambient temperature of $25 \pm 5 \text{ }^\circ\text{C}$, a relative humidity of $60 \pm 15\%$, an air pressure of 86 to 106 kPa, a supply voltage of $12 \pm 0,3 \text{ V}$ and an a.g.c. voltage of $10 \pm 0,2 \text{ V}$.

General

Semiconductors, v.h.f. bands

r.f. amplifier	BF982
mixer/i.f. amplifier	2 x BF324
oscillator	BF926
tuning diodes	4 x BB809
switching diodes	3 x BA482, 1 x BA483, 1 x BA484
d.c. blocking diode	1N4148 or BAS15

Semiconductors, u.h.f. bands

r.f. amplifier	BF980
oscillator	BF970
mixer	1SS99
tuning diodes	4 x OF643
frequency divider	SP4632 ($\div 64$), SP4653 ($\div 256$)

Ambient temperature range

operating	0 to $+ 60 \text{ }^\circ\text{C}$
storage	-25 to $+ 70 \text{ }^\circ\text{C}$

Relative humidity

max. 95%

UL/CSA requirements

All insulating material is UL and CSA recognized.
All parts meet the flammability specification UL94HB.

Voltages and currents

Supply voltage (V_B)

$+ 12 \text{ V} \pm 10\%$

Current drawn from $+ 12 \text{ V}$ supply

v.h.f. bands	max. 50 mA; typ. 44 mA
u.h.f. bands	max. 50 mA; typ. 44 mA

Bandswitch voltages (V_S)

$+ 12 \text{ V} \pm 10\%$, deviation from V_B less than $+ 10/-5\%$

band	terminal			
	2	4	5	7
low v.h.f.	0	$+ 12 \text{ V}$	0	$+ 12 \text{ V}$
high v.h.f.	0	0	$+ 12 \text{ V}$	$+ 12 \text{ V}$
u.h.f.	$+ 12 \text{ V}$	0	0	$+ 12 \text{ V}$

Ripple susceptibility of V_B and V_S

min. 5 mV p-p

Frequency divider supply voltage

$5 \text{ V} \pm 0,5 \text{ V}$

A.G.C. voltage (Figs 4 to 9)			
voltage range		+ 10 to 0 V	
voltage at maximum gain		+ 10 ± 0,2 V	
voltage at minimum gain		+ 1 V	
voltage :			
v.h.f. band at 50 dB gain reduction		+ 1 to + 5 V	
u.h.f. band at 30 dB gain reduction		+ 1 to + 5 V	
A.G.C. current		max. 20 µA	
Slope of a.g.c. characteristic, within channel A2 to A69		max. 200 dB/V	
A.G.C. time constant (when driven from a 10 kΩ source)		max. 8 ms	
Tuning voltage range (Figs 10, 11 and 12)		+ 0,65 to + 28 V	
Max. permissible tuning voltage		35 V (max. 100 µA)	
Tuning voltages	typical	minimum	maximum
channel A2	3 V	2 V	4 V
channel A6	15 V	12 V	19 V
channel A7	11 V	8 V	17 V
channel A13	22 V	20 V	26 V
channel A14	1,5 V	1 V	3 V
channel A83	24 V	20 V	27 V
Current drawn from 28 V tuning voltage supply			
at T _{amb} = 25 °C, R.H. = 60%		max. 0,5 µA	
at T _{amb} = 25 °C, R.H. = 95%		max. 2 µA	
at T _{amb} = 55 °C, R.H. = 60%		max. 2 µA	
The frequency divider operates at tuning voltages between 0 and 30 V.			
Tuning voltage time constant*		max. 1,5 ms	
Frequencies			
Frequency ranges			
low v.h.f.		channel A2 (picture carrier 55,25 MHz) to channel A6 (picture carrier 83,25 MHz). Margin at the extreme channels: min. 2,75 MHz	
high v.h.f.		channel A7 (picture carrier 175,25 MHz) to channel A13 (picture carrier 211,25 MHz). Margin at the extreme channels: min. 3,75 MHz	
u.h.f.		channel A14 (picture carrier 471,25 MHz) to channel A83 (picture carrier 885,25 MHz). Margin at channel A14: min. 3 MHz. Margin at channel A83: min. 4 MHz.	
Intermediate frequencies			
picture		45,75 MHz	
sound		41,25 MHz	
		The oscillator frequency is higher than the aerial signal frequency.	

* When driven from a 10 kΩ source.

Typical a.g.c. characteristics

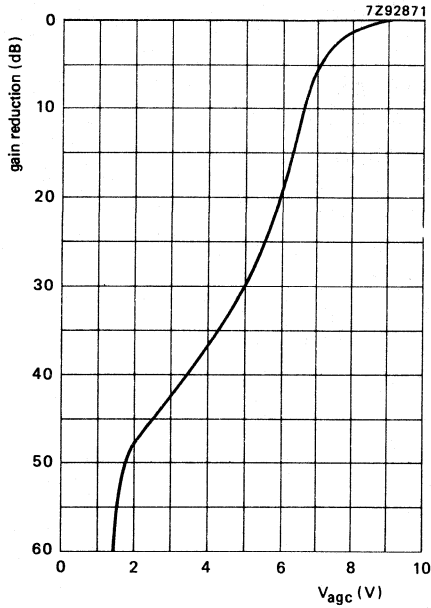

Fig. 4 Channel A2.

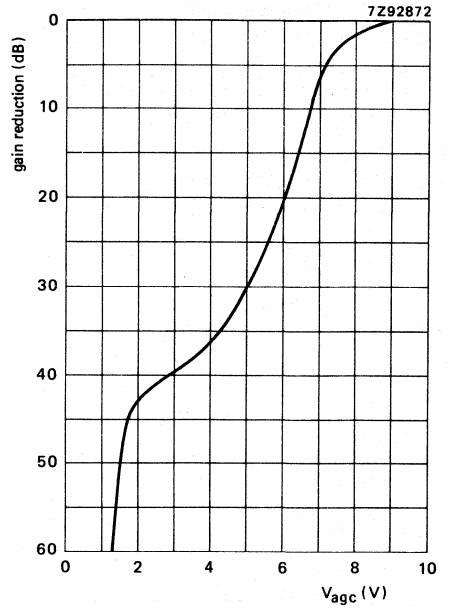

Fig. 5 Channel A6.

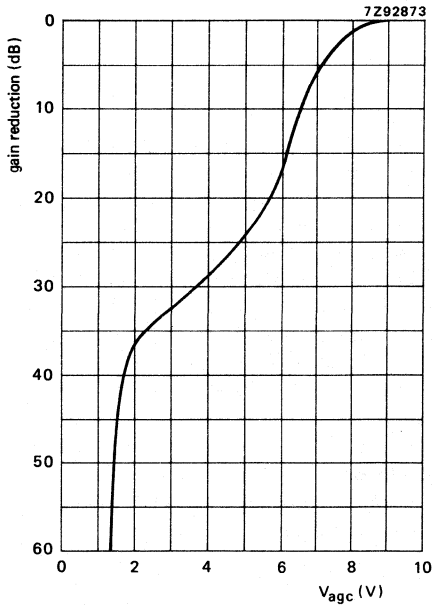

Fig. 6 Channel A7.

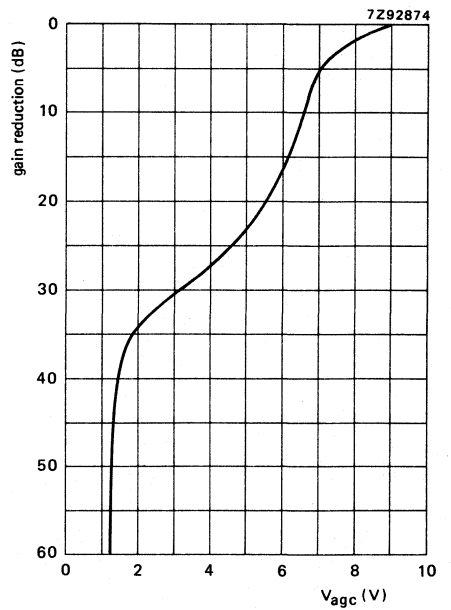

Fig. 7 Channel A13.

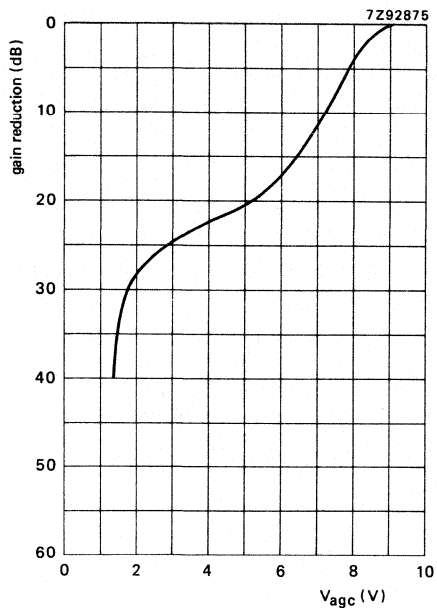

Fig. 8 Channel A14.

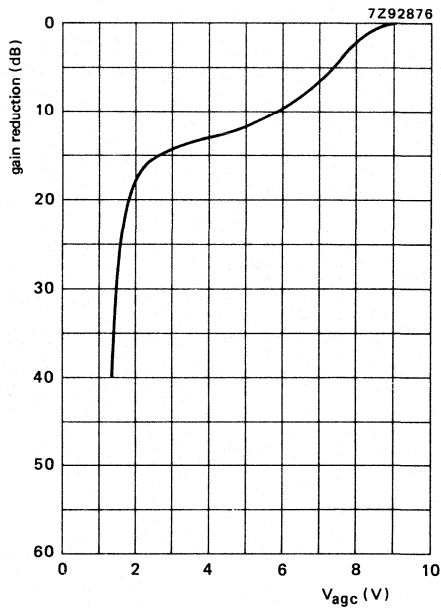

Fig. 9 Channel A70.

Typical tuning characteristics

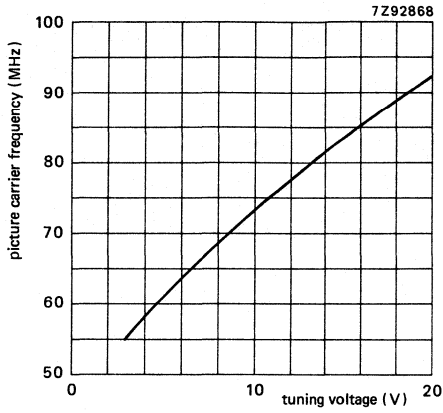

Fig. 10 Low v.h.f. band.

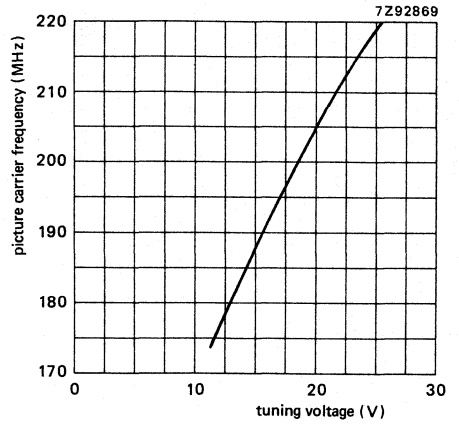

Fig. 11 High v.h.f. band.

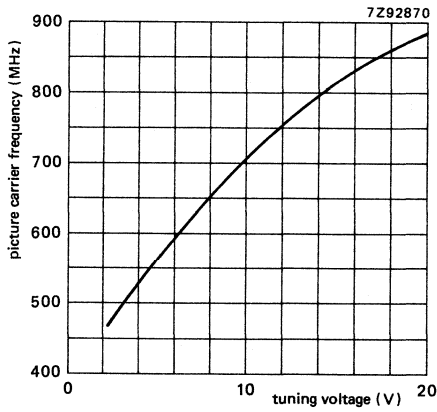

Fig. 12 U.H.F. bands.

Wanted signal characteristics

Input impedance	75 Ω	
V.S.W.R. and reflection coefficient (values between picture and sound carrier, as well as values at picture carrier)		
v.s.w.r.	at nominal gain	during gain control
v.h.f. bands	max. 5	max. 5
u.h.f. bands	max. 5	max. 5
reflection coefficient		
v.h.f. bands	max. 60%	max. 66%
u.h.f. bands	max. 66%	max. 66%
R.F. curves, bandwidth		
low v.h.f.	typ. 11 MHz	max. 15 MHz
high v.h.f.	typ. 13 MHz	max. 15 MHz
u.h.f.	typ. 20 MHz	max. 30 MHz
R.F. curves, tilt	on any channel the amplitude difference between the top of the r.f. resonant curve and the picture frequency, the sound frequency, or any frequency between them will not exceed 3 dB at nominal gain, and 4 dB in the a.g.c. range between nominal gain and 20 dB gain reduction.	
A.G.C. range		
v.h.f. bands	min. 50 dB	
u.h.f. bands	min. 30 dB	
Power gain (see also Measuring method of power gain)		
low v.h.f., 55 MHz	} min. 26 dB, max. 40 dB	
83 MHz		
high v.h.f., 175 MHz		
211 MHz		
u.h.f., 471 MHz		
579 MHz		
885 MHz		
Maximum gain difference		
between any two v.h.f. channels	typ.	3 dB
between any two u.h.f. channels	typ.	4 dB
between any v.h.f. and u.h.f. channel	typ.	5 dB
Noise figure		
low v.h.f., 55 MHz	max.	6 dB
83 MHz	max.	7 dB
high v.h.f., 175 MHz	max.	6 dB
211 MHz	max.	6 dB
u.h.f. 471 MHz	max.	10 dB
801 MHz	max.	10 dB
885 MHz	max.	12 dB
Input signal producing 1 dB gain compression at nominal gain	min. 80 dB (μ V)	

Unwanted signal characteristics

Image rejection (measured at picture carrier frequency)

v.h.f. bands	min. 60 dB; typ. 70 dB
u.h.f. band, channels A14 to A69	min. 45 dB; typ. 58 dB
u.h.f. band, channels A70 to A72	min. 40 dB; typ. 53 dB

I.F. rejection (measured at picture carrier frequency)

v.h.f. bands	min. 60 dB
u.h.f. bands	min. 60 dB

½ i.f. interference

v.h.f. bands	min. 75 dB (µV)
u.h.f. bands	min. 65 dB (µV)

920 kHz beat

channels A2 to A69 (a.g.c. from 0 to 30 dB)	55 dB
channels A55 to A69 (a.g.c. from 0 to 20 dB)	55 dB

FM rejection

channel A6, 90,5 MHz	min. 50 dB
channel A6, 93 MHz to 100 MHz	min. 50 dB

Colour beat, channel A6

min. 50 dB

CB susceptibility

min. 108 dB (µV)

Breakthroughs

min. 70 dB (µV)

Cross modulation

(1% modulation transfer from unwanted to wanted signal).

The undesired carrier level shall be equal to or exceed the desired carrier level for all gain values between maximum gain and 40 dB (v.h.f.), 30 dB (u.h.f.) gain reduction or be:

in v.h.f. channel	min. 70 dB (µV)
in u.h.f. channel	min. 70 dB (µV)
in v.h.f. band (± 12 MHz)	min. 78 dB (µV)
in u.h.f. band (± 5 channels)	min. 84 dB (µV)

Oscillator characteristics**Pulling**

Input signal of tuned frequency producing a shift of the oscillator frequency of 10 kHz, at nominal gain

min. 74 dB (μ V) into 75 Ω

Shift of oscillator frequency at a change of the supply voltage of 5%

v.h.f. bands

max. 250 kHz

u.h.f. channels A14 to A69

max. 400 kHz

u.h.f. channels A70 to A83

max. 700 kHz

Drift of oscillator frequency

during warm-up time (after the tuner has been completely out of operation for 15 min, measured between 5 s and 15 min after switching on)

max. 250 kHz

during warm-up time (after the input stage is in operation for 15 min, measured between 2 s and 15 min after band switching)

max. 250 kHz

at a change of the ambient temperature from + 25 to + 50 °C (measured after 3 cycles from + 25 to + 55 °C)

v.h.f. bands

max. 350 kHz

u.h.f. bands

max. 1000 kHz

Drift of oscillator frequency

at a change of humidity from R.H. = 60 \pm 2% to R.H. = 93 \pm 2%

$T_{amb} = 25 \pm 5$ °C

low v.h.f.

max. 500 kHz

high v.h.f.

max. 1000 kHz

u.h.f. channel A14

max. 1000 kHz

u.h.f. channel A83

max. 1500 kHz

Shift during a.g.c.

v.h.f.

max. 150 kHz

u.h.f. channels A14 to A69

max. 150 kHz

u.h.f. channels A70 to A83

max. 300 kHz

Frequency divider characteristics**Supply voltage**+ 5 V \pm 10%**Current drawn from + 5 V supply**

max. 35 mA; typ. 25 mA

Output voltage, output loaded with 62 Ω and 18 pF in series

min. 440 mV p-p

Interference signal on the i.f. outputmax. 10 μ V

Miscellaneous

Radio interference

Oscillator radiation

low v.h.f. band,

high v.h.f. band

u.h.f. bands, any single frequency

u.h.f. bands, average of ten individual frequencies

max. 50 $\mu\text{V}/\text{m}$

max. 150 $\mu\text{V}/\text{m}$

max. 750 $\mu\text{V}/\text{m}$

max. 350 $\mu\text{V}/\text{m}$

Microphonics

There will be no microphonics, provided the tuner is installed in a professional manner.

Surge protection

Protection against voltages

max. 5 kV

Note: 10 discharges of a 470 pF capacitor into the aerial terminal.

Protection against flashes

max. 30 kV, 400 mWs

Note: A flashover circuit producing flashes with frequencies of 1 to 20 Hz for 30 s is connected to the aerial terminal.

ADDITIONAL INFORMATION

I.F. injection

The test point (T.P.) connected to the collector of the v.h.f. mixer transistor can be used for i.f. injection via a capacitance of 0,3 pF.

The tuner can be switched to either a v.h.f. or a u.h.f. band, with a tuning voltage of at least 5 V. Attenuation of injected signal is 20 dB.

Connection of the i.f. amplifier

No special precautions are required to load and to match the i.f. output of the tuner.

Connection of supply voltages

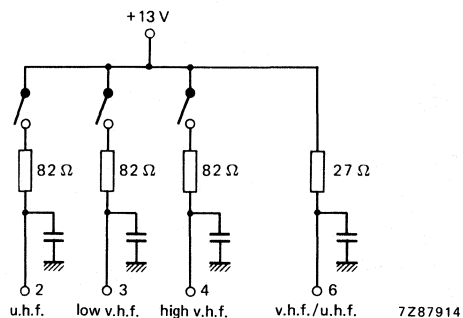

Fig. 13.

Method of measuring power gain

The i.f. output of the tuner should be terminated with 75Ω .

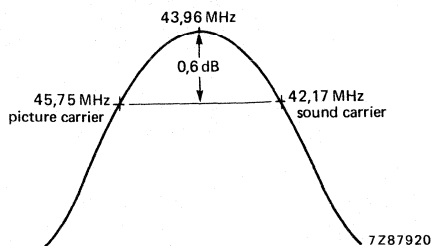

Fig. 14.

No further i.f. alignment is necessary.

Alignment of the i.f. output coil

The i.f. output coil should be adjusted with a brass tool with a blade as shown in Fig. 14. A suitable tool is available under catalogue number 7122 005 47680.

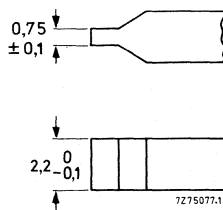

Fig. 15.

U.H.F. TELEVISION TUNERS

QUICK REFERENCE DATA

Systems	C.C.I.R. systems I (United Kingdom), G, H and K	
Channels	E21 to E69	
	<u>systems I and K</u>	<u>systems G and H</u>
Intermediate frequencies		
picture	39.5 MHz	38.9 MHz
sound	33.5 MHz	33.4 MHz

APPLICATION

These tuners are for use in u.h.f. single-standard receivers. In combination with v.h.f. tuner V317 or V334 they can be used in v.h.f./u.h.f. receivers.

The tuners meet the special requirements of the United Kingdom.

The U341LO Mark 2 is a special version of the U341 Mark 2; an output voltage sample from the local oscillator is available for driving digital tuning systems. Apart from this the tuners are identical.

The tuners are pin-compatible with tuners U341 and U341LO; the a.g.c. circuit is voltage driven.

DESCRIPTION

These are u.h.f. tuners with electronic tuning, covering the u.h.f. band from 470 to 860 MHz (channels E21 to E69). The tuner circuit is built on a printed-wiring board and enclosed in a metal housing comprising a rectangular frame and front and rear covers (see Fig.2a). The shielded aerial connection is on one of the shortest frame sides, all other connections (supply voltages, a.g.c., tuning voltage, i.f. injection, i.f. output) are made via terminals on the underside. The mounting method is shown in Figs.3 and 4.

Tuner U341LO Mark 2 has a coaxial socket on the top of the frame for the oscillator output sample.

Electrically, the tuners consist of an input circuit with a high-pass characteristic and a MOS-FET tetrode BF980. This tetrode operates at a drain current of about 10 mA, and has good noise figures and signal handling properties. It also acts as an a.g.c. device, controlled by an a.g.c. voltage fed to gate 2. This combination has good signal handling properties throughout the a.g.c. range. The drain load of the MOS-FET tetrode is formed by a double tuned circuit which transfers the signal to the mixer diode 1SS99. The selectivity of this circuit at the image frequency has been improved by special means. The mixer diode is driven by an oscillator transistor BF970. For the U341LO Mark 2 the oscillator sample is fed out of the oscillator via a resistor.

The i.f. signal, from the mixer is amplified by a transistor BF324 in grounded-base configuration. The combination of the Schottky-barrier diode 1SS99 and the i.f. transistor BF324 ensures good noise figures and signal handling properties. Three capacitance diodes OF643 tune the double tuned circuit and the oscillator.

The i.f. output circuit is single tuned with output coupling from the low impedance side. A d.c. path to earth for the collector current of the i.f. transistor BF324 must be provided outside the tuner, preferably by a choke of about 5 μ H. Damping of the i.f. output circuit and matching to the i.f. circuit of the receiver can be achieved by connecting a series resistance and a parallel capacitance outside the tuner.

An i.f. injection point is provided at the collector of the i.f. transistor, connected to terminal 7. U341LO Mark 2 has a special connection to provide an oscillator output for driving digital tuning systems.

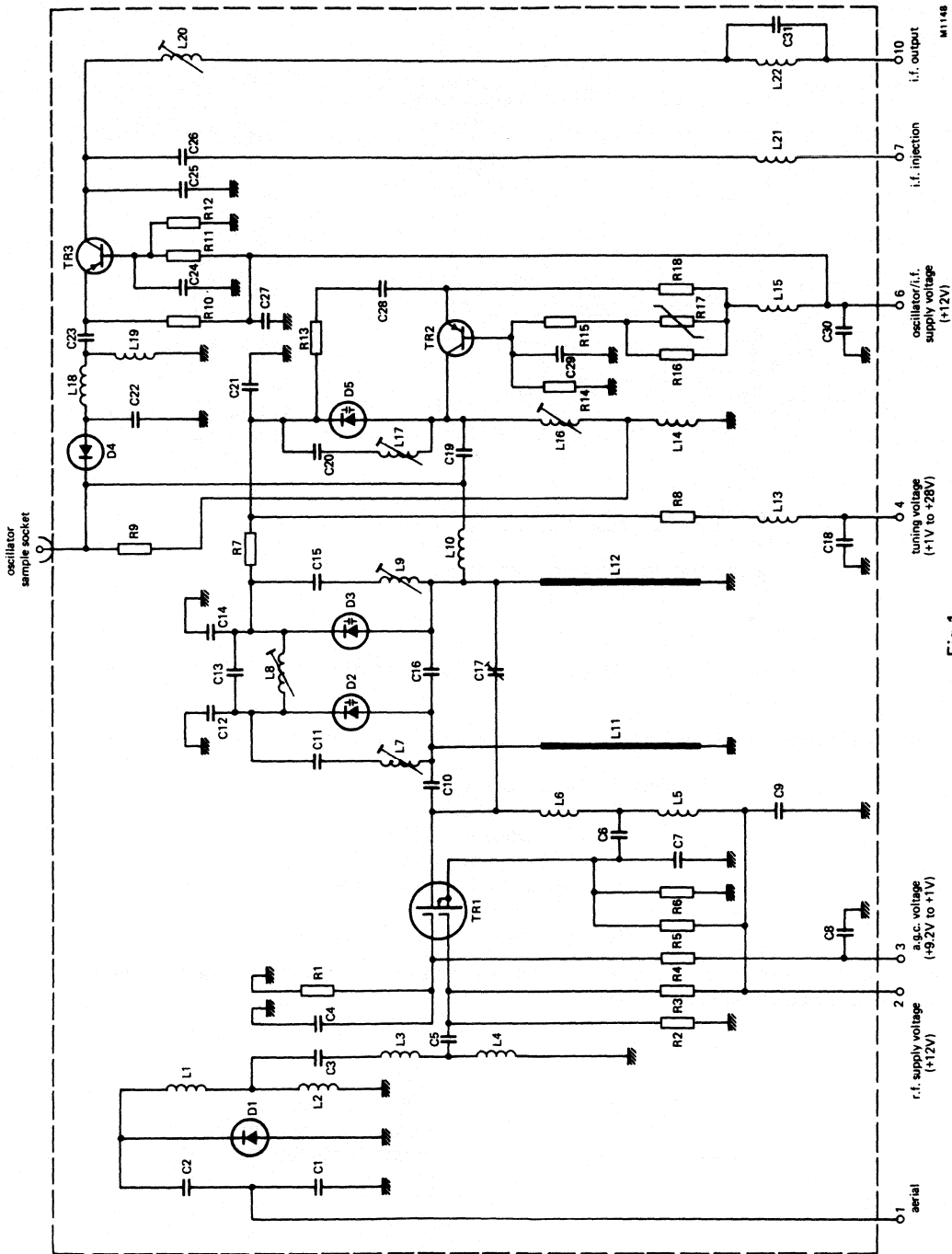

Fig. 1

MECHANICAL DATA

Dimensions in mm

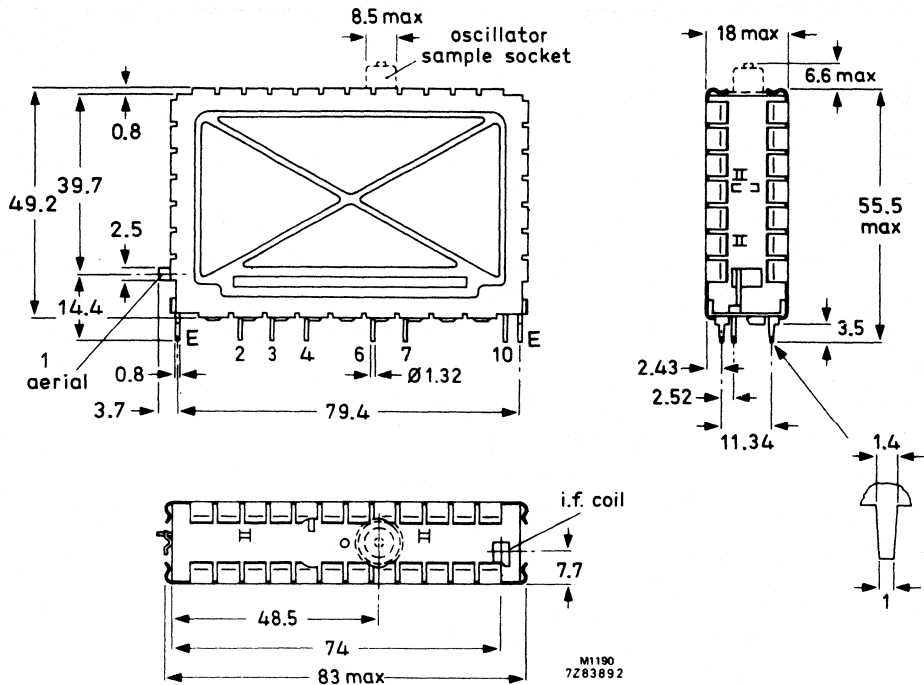

Fig.2a The oscillator sample socket, drawn with dotted lines, applies only to tuner U341LO Mark 2.

- Terminal 1 = aerial connection
 2 = r.f. supply voltage, +12 V
 3 = a.g.c. voltage, +9.2 to +1 V
 4 = tuning voltage, +1 to +28 V
 6 = oscillator/i.f. supply voltage, +12 V
 7 = i.f. injection point
 10 = i.f. output

Note: When the tuner is operated together with a v.h.f. tuner, only the supply voltage at terminal 6 should be switched off during v.h.f. operation.

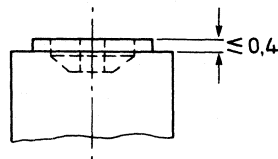

Fig.2b I.F. output coil.
 Torque for alignment: 2 to 15 mNm
 Press-through force: ≥ 10 N

Mass approx. 75 g

Mounting

The tuner may be mounted by soldering it on to a printed-wiring board with connections as shown by the piercing diagram in Fig.3. (The tuner may also be mounted in a socket. See under accessories). It is recommended that the tuner be installed in a cool part of the receiver cabinet and not exposed to the vibrations of the loudspeaker. There are no restrictions on orientation.

The solderability of the terminals and mounting tabs is according to IEC 68-2, test Ta ($230 \pm 10 \text{ }^\circ\text{C}$, $2 \pm 0.5 \text{ s}$). The resistance to soldering heat is according to IEC 68-2, test Tb ($260 \pm 5 \text{ }^\circ\text{C}$, $10 \pm 1 \text{ s}$).

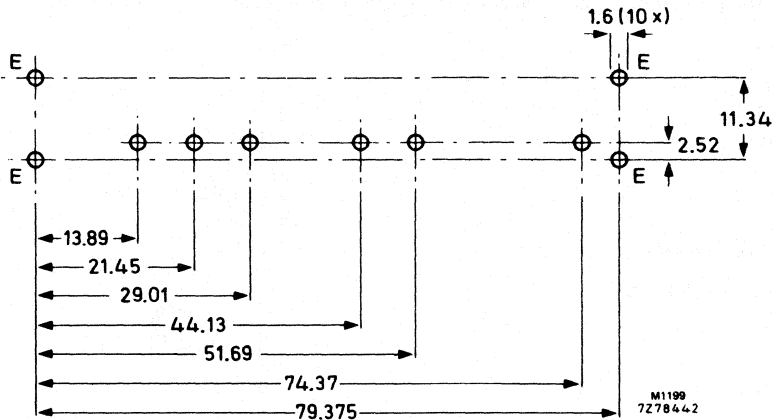

Fig.3 Piercing diagram viewed from solder side of board

A coaxial plug has to be used for connection to the socket on the top of tuner U341LO Mark 2; type 3/2-50 (manufacturer: Daut und Rietz) is recommended. (See under accessories).

The aerial cable should be connected as follows:

- strip the cable according to Fig. 4B;
- fix the cable as indicated in Fig.4 C and solder the inner conductor on the aerial tag;
- insert the lugs on immunity shield under the tabs on tuner body, push the shield into position so that the locating tags snap into place in the tuner body.

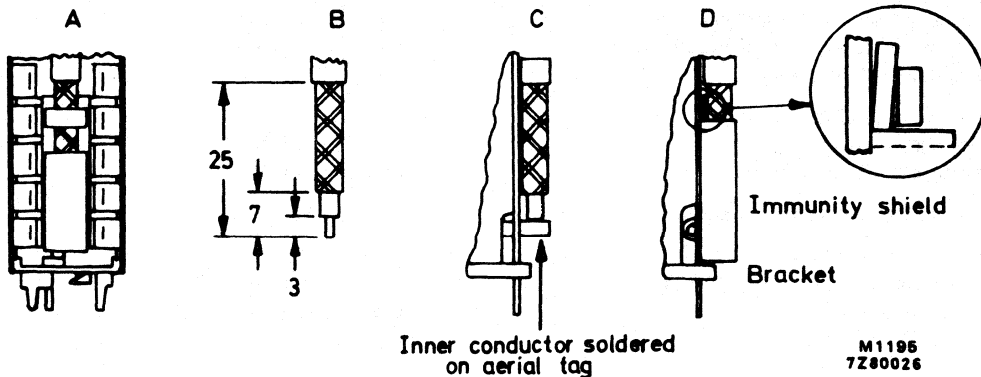

Fig.4 Fixing of the aerial cable.

Recommended cable: DAVU wire CX4004 (outer sheath diameter 5.32 mm).

ELECTRICAL DATA

The electrical values are measured on the u.h.f. tuner alone, but they are also valid for the u.h.f. tuner when used with a v.h.f. tuner V317 or V334, Unless otherwise specified all electrical values apply at an ambient temperature of 25 ± 5 °C, a relative humidity of $60 \pm 15\%$, a supply voltage of 12 ± 0.3 V and an a.g.c. voltage of 9.2 ± 0.2 V.

Within the given tolerance range of supply voltage and a.g.c. voltage only insignificant deviations from the specified values can be expected. Under the extreme conditions of temperature and humidity as given below, the tuner will function normally, but some specified limits may be exceeded.

General

Semiconductors

r.f. amplifier	BF980
mixer diode	1SS99
oscillator	BF970
tuning diodes	3 x OF643
i.f. amplifier	BF324
surge protection diode	BAV10

Ambient temperature range

operating	-10 to +60 °C
storage	-25 to +85 °C

Relative humidity

max. 90%

Voltages and currents

Supply voltage +12 V \pm 10%

Note: The supply voltage at terminal 2 (input stage) should be filtered to avoid hum modulation.

Ripple susceptibility

Defined as the peak-to-peak value of a sine wave signal (20 Hz – 500 kHz) on the supply voltages causing an amplitude modulation with a modulation depth of 0.28% on the picture carrier after passing the Nyquist curve of the i.f. filter of a tv receiver.

ripple susceptibility min. 3 mV peak-to-peak

Current drawn from +12 V supply

r.f. amplifier, at nominal gain	typ.	< 21 mA
r.f. amplifier, at 30 dB gain reduction	typ.	11 mA
oscillator/i.f. amplifier	max.	< 16 mA

A.G.C. voltage (Fig.5)

voltage at nominal gain	+ 9.2 \pm 0.5 V
voltage at 30 dB gain reduction	min. + 1 V

Note: A.G.C. voltages between 0 and +10 V may be applied without risk of damage.

A.G.C. current (Fig.5)

during gain control (0 to 30 dB)	max.	+ 1 mA
at nominal gain	typ.	+ 0.9 mA
at 30 dB gain reduction	typ.	+ 0.1 mA

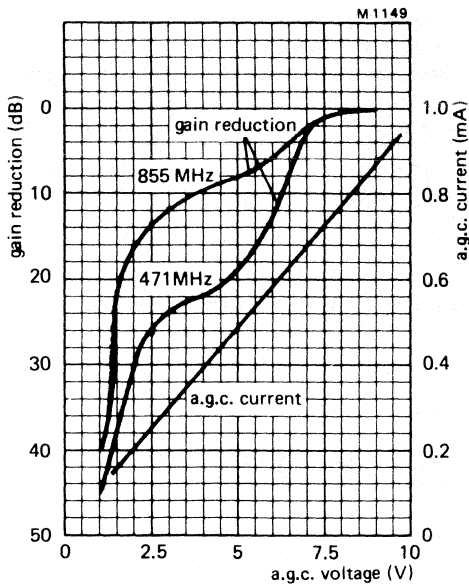

Fig.5

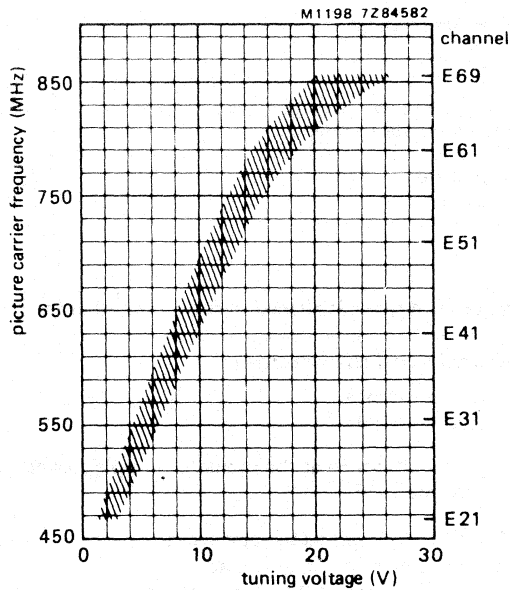

Fig.6

Tuning voltage range (Fig.6)

+ 1 to + 28 V

Current drawn from + 28 V tuning voltage supply
at 25 °C
at 55 °C

max. 0.15 μ A

max. 0.6 μ A

Slope of tuning characteristic

min. 4 MHz/V

Note: The source impedance of the tuning voltage offered to terminal 4 must be maximum 47 k Ω at tuning voltages below 3 V.

Oscillator sample signal; **only valid for U341LO Mark 2**

at + 12 V supply voltage and

$T_{amb} = + 25$ °C

within the given tolerance range of supply
voltage and given operating temperature range,

and within the tuning voltage range + 0.5 to + 30 V

typ. 90 dB (μ V) into 75 Ω

min. 80 dB (μ V) into 75 Ω

max. 105 dB (μ V) into 75 Ω

Note: A tuning voltage higher than + 28 V will not damage the tuner and may be applied at the user's own risk. Under this condition the published reverse voltage limit of the oscillator tuning diode will be exceeded; the oscillator frequency will never decrease with increasing tuning voltage.

Frequencies

Frequency range

channel E21 (picture carrier 471.25 MHz) to channel E69 (picture carrier 855.25 MHz). Margin at the extreme channels: min. 3 MHz.

Intermediate frequencies

picture
sound

systems I, K	systems G, H
39.5 MHz	38.9 MHz
33.5 MHz	33.4 MHz

The oscillator frequency is higher than the aerial signal frequency.

Note: The tuner is aligned in such a way that the i.f. frequencies of the four systems can be applied.

Wanted signal characteristics

Input impedance
asymmetrical

75 Ω

Output impedance at the oscillator sample socket; only valid for U341LO Mark 2
asymmetrical

75 Ω

V.S.W.R. and reflection coefficient
at picture carrier frequency, at
nominal gain and at 30 dB gain reduction

v.s.w.r.
reflection coefficient

max. 6
max. 71%

V.S.W.R. and reflection coefficient* at oscillator sample socket; only valid for U341LO Mark 2
v.s.w.r. at f_{osc} 80 MHz – 900 MHz
reflection coefficient
at f_{osc} 80 MHz – 900 MHz

max. 3.5
max. 56%

R.F. curves, bandwidth

typ. 20 MHz

R.F. curves, tilt (only for i.f. 39.5/33.5 MHz)

on any channel the amplitude difference between the top of the r.f. resonant curve and the picture frequency, the sound frequency, or any frequency between them will not exceed 3 dB at nominal gain, and 4 dB in the a.g.c. range between nominal gain and 20 dB gain reduction.

A.G.C. range

min. 30 dB

*Measured in operational and non-operational condition of the tuner.

Power gain (see also Measuring method of power gain)	min.	20 dB
channel E21	typ.	27 dB
channel E40	typ.	25 dB
channel E69	typ.	27 dB
Gain difference between any two channels	typ.	4 dB
Noise figure	max.	10 dB
channel E21	typ.	5.5 dB
channel E40	typ.	6.5 dB
channel E69	typ.	7 dB
Overloading		
Input signal producing 1 dB gain compression at nominal gain	typ.	90 dB (μ V) into 75 Ω
Input signal producing either a detuning of the oscillator of + 300 kHz or -1000 kHz or stopping of the oscillations at nominal gain	typ.	100 dB (μ V) into 75 Ω
1.6 MHz moiré rejection (for i.f. 39.5/33.5 MHz)		
Wanted signal level of a tv signal (picture to sound ratio of 7 dB and picture to chroma ratio of 16 dB), produces an unwanted i.f. component (37.8 MHz) 52 dB below the i.f. picture carrier, when the tuner is 30 dB gain controlled. I.F. output circuit should be loaded and tuned to 36.15 MHz.		
tv signal (picture carrier)	typ.	100 dB (μ V)
Unwanted signal characteristics		
Image rejection (measured at picture carrier frequency)		
at nominal gain, channels E21 to E60	min.	53 dB; typ. 60 dB
at 20 dB gain reduction, channels E21 to E60	min.	50 dB; typ. 55 dB
Harmonic content of oscillator sample; only valid for U341LO Mark 2		
Suppression of harmonics which fall into the frequency range below 1200 MHz (second harmonics of fundamentals below 600 MHz)		
	min.	15 dB (typ 20 dB) below oscillator fundamental
R.F. rejection at oscillator sample socket; only valid for U341LO Mark 2		
Signal voltage at oscillator sample socket (input signals of wanted frequency 70 dB (μ V) into 75 Ω ; tuner operating at nominal gain)		
	min.	20 dB (typ. 24 to 40 dB) below oscillator fundamental
I.F. rejection (measured at picture carrier and colour sub-carrier frequency)		
	min.	80 dB
I.F. rejection at oscillator sample socket; only valid for U341LO Mark 2		
I.F. signals at oscillator sample socket (converted from input signals of wanted frequency 70 dB (μ V) into 75 Ω ; tuner operating at nominal gain)		
	min.	20 dB (typ. 27 up to 35 dB) below oscillator fundamental

1st repeat spot rejection (for i.f. 39.5/33.5 MHz)

Defined as the input level of the picture carrier of channel N + 2, the sound carrier of which produces an i.f. signal (35.0 MHz); which is 52 dB below the picture carrier of the wanted signal N (picture to sound ratio 7 dB; wanted signal 60 dB (μ V), tuner operating at nominal gain.

interfering signal	typ.	80 dB (μ V)
--------------------	------	------------------

N \pm 4 rejection

Interference signal for an interference ratio of 53 dB referred to wanted picture carrier (picture to sound carrier ratio of 7 dB; wanted signal 60 dB (μ V); tuner operating at nominal gain)

N + 4 rejection	typ.	80 dB (μ V) into 75 Ω
N - 4 rejection	typ.	78 dB (μ V) into 75 Ω

Cross modulation

Input signal producing 1% cross modulation, i.e. 1% of the modulation depth of the interfering signal is transferred to the wanted signal.

In channel cross modulation (wanted signal: picture carrier frequency, interfering signal, sound carrier frequency)

at nominal gain (wanted input level 60 dB (μ V))	typ.	80 dB (μ V) into 75 Ω
at 26 dB gain reduction (wanted input level 86 dB (μ V))	typ.	94 dB (μ V) into 75 Ω

In band cross modulation (wanted signal: picture carrier of channel N; interfering signal: picture carrier of channel N \pm 3 and N \pm 5).

at nominal gain (wanted input level 60 dB (μ V))	typ.	92 dB (μ V) into 75 Ω
at 26 dB gain reduction (wanted input level 86 dB (μ V))	typ.	95 dB (μ V) into 75 Ω

Out of band modulation, at nominal gain

v.h.f. I	min.	108 dB (μ V) into 75 Ω
v.h.f. III	min.	108 dB (μ V) into 75 Ω

Unwanted signal handling capability

The tuner operates together with a standard tv receiver with normal A.G.C. for tuner and i.f. amplifier. Unwanted tv signal 3 channels higher or lower than wanted. Unwanted signal level adjusted for just not visible interference.

Unwanted picture carrier signal	typ.	96 dB (μ V)
---------------------------------	------	------------------

Oscillator characteristic**Pulling**

Input signal of tuned frequency producing a shift of the oscillator frequency of 10 kHz, at nominal gain typ. 85 dB (μ V) into a 75 Ω

Shift of oscillator frequency (Δ F)
at a change of the supply voltage of 5% max. 500 kHz

Drift of oscillator frequency

during warm-up time (after the tuner has been completely out of operation for 15 min, measured between 5 s and 15 min after switching on) max. 250 kHz

during warm-up time (after the input stage is in operation for 15 min, measured between 2 s and 15 min after switching on oscillator/i.f. stage) max. 250 kHz

at a change of the ambient temperature from + 25 to + 50 $^{\circ}$ C and + 25 $^{\circ}$ C to 0 $^{\circ}$ C (measured after 3 cycles from + 25 to + 55 $^{\circ}$ C) channels E21 to E69 max. 1000 kHz

at a change of humidity from 60% \pm 15% to 93% \pm 2% measured at T_{amb} 25 $^{\circ}$ C \pm 5 $^{\circ}$ C, max. 1500 kHz

I.F. characteristics

Bandwidth of i.f. output circuit $5^{+1}_{-0.5}$ MHz

Note: I.F. output of the tuner terminated with the circuit shown in Fig.9, tuning voltage 15 V.

Bandwidth variation of i.f. output circuit as a result of r.f. tuning max. 500 kHz

Note: I.F. output of the tuner terminated with a modified circuit of Fig.9, i.e. a 100 pF capacitor is connected in parallel with C1; tuning voltage 15 V.

Detuning of the i.f. output circuit as a result of r.f. tuning max. 500 kHz

Note: I.F. output of the tuner terminated with a modified circuit of Fig.9, i.e. a 100 pF capacitor is connected in parallel with C1; tuning voltage 15 V.

Minimum tuning range of i.f. output coil 33 to 40 MHz

Note: I.F. output of the tuner terminated with the circuit shown in Fig.10, tuning voltage 15 V.

Attenuation between i.f. injection point and i.f. output of the tuner typ. 23 \pm 3 dB

Miscellaneous

Radio interference

Oscillator radiation and oscillator voltage
at the aerial terminal

Within the limits of C.I.S.P.R. 13 (1975).
Use is made of the relaxed limit of 3 mV/m
(70 dB (μ V/m)).

Immunity from radiated interference

Aerial terminal meets requirements
of BS905, provided the aerial cable is
connected in a professional manner.

Microphonics

There will be no microphonics, provided
the tuner is installed in a professional
manner.

Surge protection

Protection against voltages

max. 5 kV

Note: Ten discharges of a 470 pF capacitor into the aerial terminal.

Protection against flashes

max. 30 kV, 400 mWs

Note: A flashover circuit producing flashes with frequencies of 1 to 20 Hz for 30 s is connected to the aerial terminal.

ADDITIONAL INFORMATION

I.F. injection

The tuner has an i.f. injection point at the collector of the i.f. transistor (coupled via a small capacitor to terminal 7). The i.f. generator can be connected directly to this point (Fig.7).

The tuner needs normal supply voltages and a tuning voltage of 15 V; the i.f. output should be loaded with the circuit shown in Fig.9.

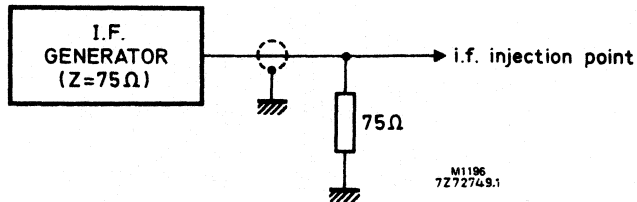
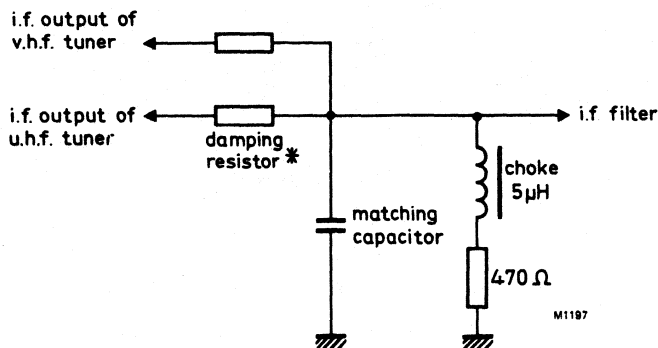

Fig.7

Connection of the i.f. amplifier

The tuner needs a d.c. path from the i.f. output terminal (10) to earth, preferably via a choke of approx. $5 \mu\text{H}$ outside the tuner (Fig.8). Where the tuner is used in combination with a v.h.f. tuner, this choke can be common for both tuners; a resistor in series with the choke can inhibit the i.f. output circuit of the switched-off tuner. For damping the i.f. output circuit and matching the i.f. output impedance of the tuner to the receiver i.f. amplifier, a series resistor and a parallel capacitor as shown in Fig.8 should be used.



* Eventually the two separate damping resistors may be replaced by a common one.

Fig.8

Measuring method of power gain

The i.f. output of the tuner should be terminated with the RC-circuit given in Fig.9.

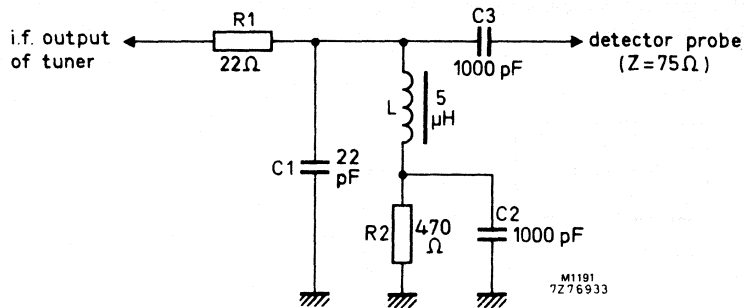

Fig.9

The RC-circuit roughly matches the i.f. output impedance to 75 Ω at the resonant frequency of the i.f. output circuit, which should be tuned to 36.5 MHz; the bandwidth should be approx. 5 MHz (Fig. 10).

Because the input and output impedances of the tuner are now 75 Ω, the power gain can be measured in the conventional manner by inserting tuner and RC-circuit between a 75 Ω source and a 75 Ω detector.

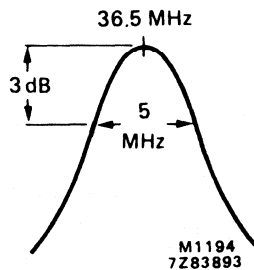

Fig.10

Alignment of the i.f. output coil

The i.f. output coil should be adjusted with a plastic tool, which has a cross head according to Fig.11.
A suitable tool for automatic alignment is available under catalogue number 8104 004 11040.

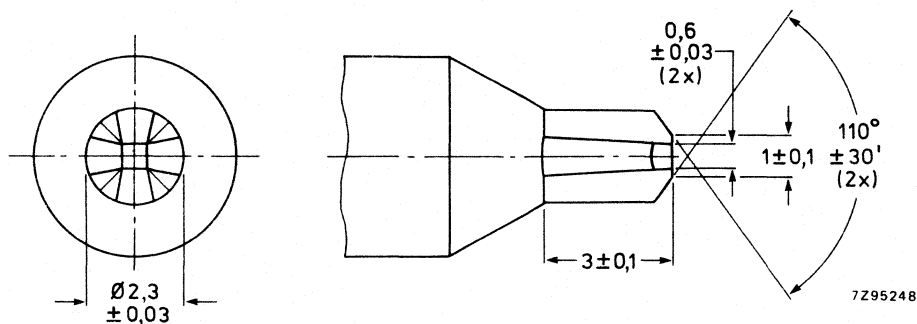

Fig.11

ACCESSORIES

Immunity shield, catalogue number 3122 121 24910

Connector assembly for use of tuner U341 Mark 2 or U341LO Mark 2 in combination with v.h.f. tuner V317 or V334:

connector, catalogue number 3112 200 20720

clamp holder, catalogue number 3122 121 29260

clamp, catalogue number 3112 274 13220

U.H.F. TELEVISION TUNERS

QUICK REFERENCE DATA

Systems	C.C.I.R. systems G, H, I and K	
Channels	E21 to E69	
Intermediate frequencies	systems G and H	systems I and K
	picture	39,5 MHz
	sound	33,5 MHz

APPLICATION

These tuners are designed to cover the u.h.f. channels E21 to E69 of C.C.I.R. systems G, H, I and K. In combination with a suitable v.h.f. tuner, e.g. V317 or V334, they can be used in v.h.f./u.h.f. receivers. The aerial inputs and i.f. outputs of both tuners can then be connected in parallel.

The U342LO is a special version of the U342; an output voltage from the local oscillator is made available for driving digital tuning systems. Apart from this the tuners are identical.

DESCRIPTION

The tuners are u.h.f. tuners with electronic tuning, covering the u.h.f. band from 470 to 860 MHz.

Mechanically, the tuners are built on a printed-wiring board, carrying all components, in a metal housing made of a rectangular frame, and front and rear covers (see Fig. 2a). All connections (aerial, supply voltages, a.g.c. voltage, tuning voltage, i.f. injection, i.f. output) are made via terminals on the underside. The mounting method is shown in Fig. 3. Tuner U342LO has a coaxial socket on the top of the frame for coupling out the oscillator sample.

Electrically, the tuners consist of an input circuit with a high-pass characteristic and a MOS-FET tetrode BF980. This tetrode operates at a drain current of about 10 mA, featuring good noise figures and good signal handling properties. It also acts as an a.g.c. device, controlled by an a.g.c. voltage fed to gate 2. This combination has good signal handling properties throughout the a.g.c. range. The drain load of the MOS-FET tetrode is formed by a double tuned circuit, transferring the signal to the mixer diode 1SS99. The selectivity of this circuit at the image frequency has been improved by special means. The mixer diode is driven by an oscillator, equipped with a transistor BF480. At the U342LO the oscillator sample is coupled out of the mixer via a small capacitor in series with a resistor.

The i.f. signal, originated in the mixer, is amplified by a transistor BF324 in grounded-base configuration. The combination of the Schottky-barrier diode 1SS99 and the i.f. transistor BF324 also features good noise figures and good signal handling properties. Three capacitance diodes BB405B tune the double tuned circuit and the oscillator.

The i.f. output circuit of the tuner is a single tuned one, at the low end of which the i.f. signal is coupled out of the tuner. A d.c. path to earth for the collector current of the i.f. transistor BF324 has to be provided outside the tuner, preferably by a choke of about 5 μ H. Damping of the i.f. output circuit and matching of the i.f. output to the i.f. circuit of the receiver can be achieved by connecting a series resistance and a parallel capacitance outside the tuner.

An i.f. injection point has been provided at the collector of the i.f. transistor, connected to terminal 7.

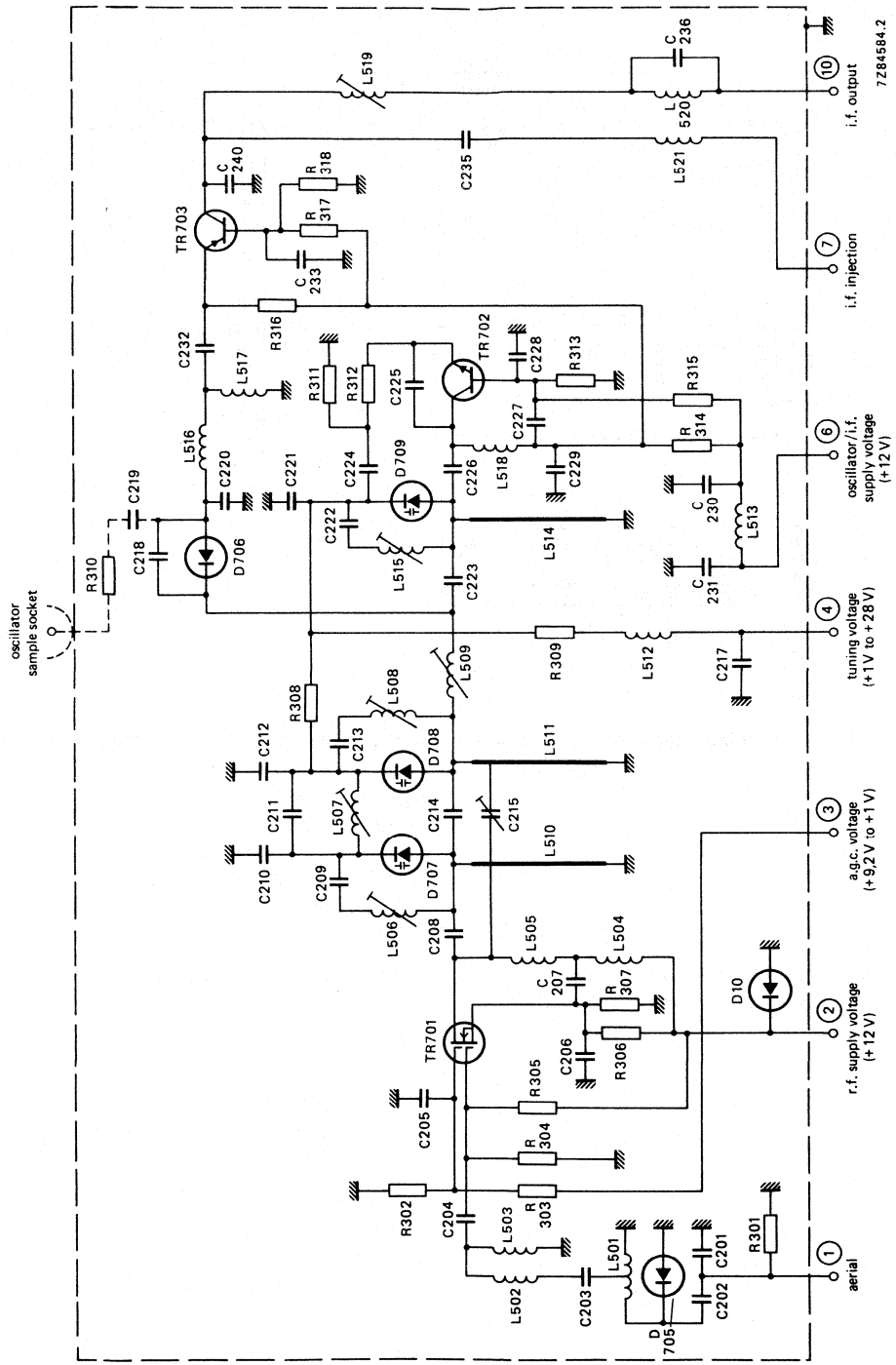

Fig. 1.

MECHANICAL DATA

Dimensions in mm

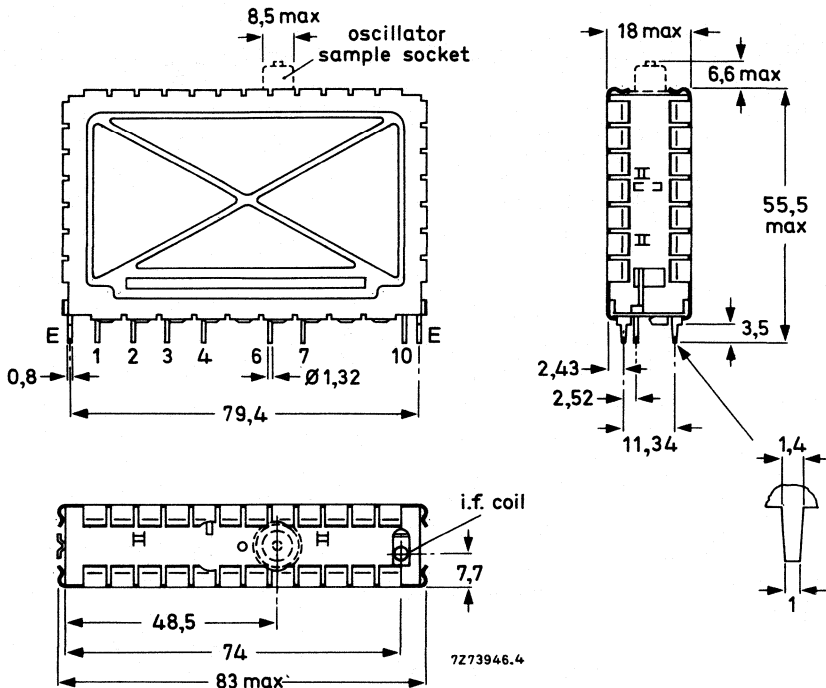

Fig. 2a The oscillator sample socket, drawn with dotted lines, applies only to tuner U342LO.

Terminal 1 = aerial

2 = r.f. supply voltage, + 12 V

3 = a.g.c. voltage, + 9,2 to + 1 V

4 = tuning voltage, + 1 to + 28 V

6 = oscillator/i.f. supply voltage, + 12 V

7 = i.f. injection point

10 = i.f. output

Note: When the tuner is operated together with a v.h.f. tuner, only the supply voltage at terminal 6 should be switched off during v.h.f. operation.

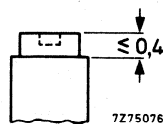

Fig. 2b I.F. output coil.

Torque for alignment: 2 to 15 mNm

Press-through force: ≥ 10 N

Mass approx. 75 g

Mounting

The tuner may be mounted by soldering it on to a printed-wiring board, using the piercing diagram shown in Fig. 3. (The tuner may also be mounted into a socket. Information will be supplied upon request.)

It is recommended that the tuner be installed in the cool part of the receiver cabinet and not exposed to the vibrations of the loudspeaker. There are no restrictions on orientation.

The solderability of the terminals and mounting tabs is according to IEC 68-2, test Ta (230 ± 10 °C, $2 \pm 0,5$ s). The resistance to soldering heat is according to IEC 68-2, test Tb (260 ± 5 °C, 10 ± 1 s).

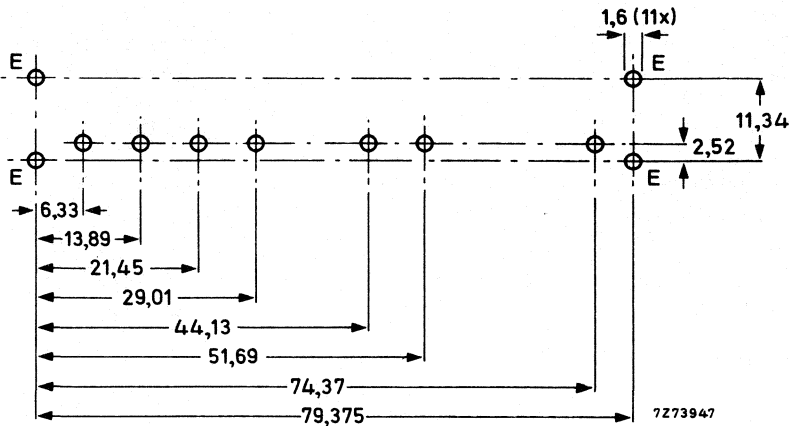

Fig. 3 Piercing diagram viewed from solder side of board.

For connection to the socket on the top of tuner U342LO a coaxial plug has to be used; type 3/2-50 (manufacturer: Daut und Rietz) is recommended.

ELECTRICAL DATA

The electrical values are measured on the u.h.f. tuner alone, but they are also valid for the u.h.f. tuner in combination with a v.h.f. tuner V317 or V334. Unless otherwise specified all electrical values apply at an ambient temperature of 25 ± 5 °C, a relative humidity of $60 \pm 15\%$, a supply voltage of $12 \pm 0,3$ V and an a.g.c. voltage of $9,2 \pm 0,2$ V.

Within the given tolerance range of supply voltage and a.g.c. voltage only insignificant deviations from the specified values can be expected. Under the extreme conditions of temperature and humidity as given below, the tuner will function normally, but some specified limits may be exceeded.

General

Semiconductors

r.f. amplifier	BF980 (3SK87)
mixer diode	1SS99
oscillator	BF480
tuning diodes	3 x BB405B
i.f. amplifier	BF324
surge protection diodes	2 x BAV10

Ambient temperature range

operating	+ 5 to + 55 °C
storage	-25 to + 85 °C

Relative humidity

max. 90%

Voltages and currents

Supply voltage

+ 12 V \pm 10%

Note: The supply voltage at terminal 2 (input stage) should be filtered to avoid hum modulation.

Current drawn from + 12 V supply

r.f. amplifier, at nominal gain	typ. 21 mA
r.f. amplifier, at 30 dB gain reduction	typ. 10 mA
oscillator/i.f. amplifier	max. 16 mA

A.G.C. voltage (Fig. 4), at nominal gain

+ 9,2 \pm 0,5 V

A.G.C. voltage, at 30 dB gain reduction

min. + 1 V

Note: A.G.C. voltages between 0 and + 10 V may be applied without risk of damage.

A.G.C. current (Fig. 4)

during gain control (0 to 30 dB)	max. + 1 mA
at nominal gain	typ. + 0,9 mA
at 30 dB gain reduction	typ. + 0,1 mA

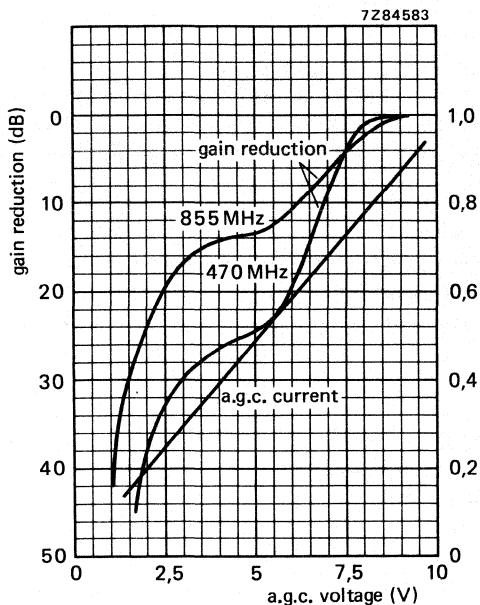

Fig. 4.

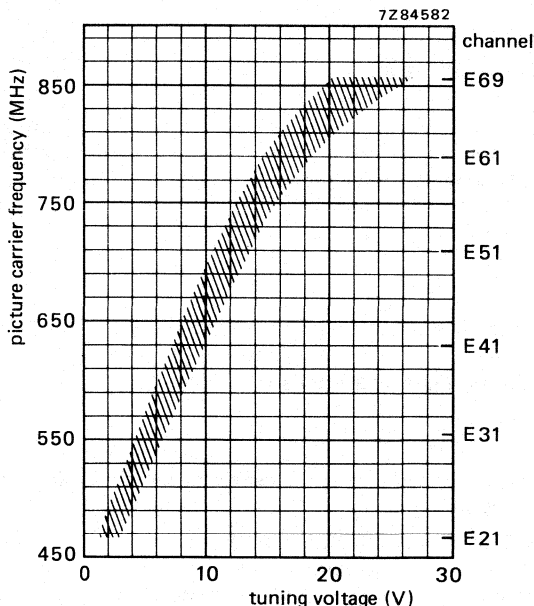

Fig. 5.

Tuning voltage range (Fig. 5)

Current drawn from +28 V tuning voltage supply
at 25 °C
at 55 °C

Slope of tuning characteristic

Note: The source impedance of the tuning voltage offered to terminal 4 must be maximum 47 kΩ at tuning voltages below 3 V.

Oscillator sample signal; **only valid for U342LO**

at +12 V supply voltage and
 $T_{amb} = +25\text{ °C}$
within the given tolerance range of supply
voltage and given operating temperature range,
and within the tuning voltage range +0,5 to +30 V

+1 to +28 V

max. 0,15 μA
max. 0,6 μA
min. 4 MHz/V

typ. 90 dB (μV) into 75 Ω

min. 80 dB (μV) into 75 Ω
max. 100 dB (μV) into 75 Ω

Note: A tuning voltage higher than +28 V will not be harmful for the tuner and may be applied at the user's own risk. Under this condition the published reverse voltage limit of the oscillator tuning diode will be exceeded; the oscillator frequency will never decrease with increasing tuning voltage.

Frequencies

Frequency range

channel E21 (picture carrier 471,25 MHz)
to channel E69 (picture carrier 855,25 MHz).
Margin at the extreme channels: min. 3 MHz.

Intermediate frequencies

picture
sound

systems G, H	systems I, K
38,9 MHz	39,5 MHz
33,4 MHz	33,5 MHz

The oscillator frequency is higher than the
aerial signal frequency.

Note: The tuner is aligned in such a way that the i.f. frequencies of the four systems can be applied.

Wanted signal characteristics

Input impedance
asymmetrical

75 Ω

Output impedance at the oscillator sample socket; **only valid for U342LO**
asymmetrical

75 Ω

V.S.W.R. and reflection coefficient
at picture carrier frequency, at
nominal gain and at 30 dB gain reduction

v.s.w.r.
reflection coefficient

max. 6
max. 71%

V.S.W.R. and reflection coefficient* at oscillator sample socket: **only valid for U342LO**

v.s.w.r. at $f_{osc} < 600$ MHz
v.s.w.r. at $f_{osc} > 600$ MHz
reflection coefficient at $f_{osc} < 600$ MHz
reflection coefficient at $f_{osc} > 600$ MHz

max. 4 (typ. 3)
max. 4 (typ. 2)
max. 60% (typ. 50%)
max. 50% (typ. 33%)

R.F. curves, bandwidth

typ. 18 MHz

R.F. curves, tilt (only for i.f. 38,9/33,4 MHz)

on any channel the amplitude difference
between the top of the r.f. resonant curve and
the picture frequency, the sound frequency,
or any frequency between them will
not exceed 3 dB at nominal gain, and 4 dB in
the a.g.c. range between nominal gain and
20 dB gain reduction.

A.G.C. range

min. 30 dB

* Measured in operational and non-operational condition of the tuner.

Power gain (see also Measuring method of power gain)	min.	20 dB
channel E21	typ.	25 dB
channel E40	typ.	24 dB
channel E69	typ.	27 dB
Gain difference between any two channels	typ.	4 dB
Noise figure	max.	10 dB
channel E21	typ.	6 dB
channel E40	typ.	6 dB
channel E69	typ.	6,5 dB
Overloading		
Input signal producing 1 dB gain compression at nominal gain	typ.	90 dB (μ V) into 75 Ω
Input signal producing either a detuning of the oscillator of +300 kHz or -1000 kHz or stopping of the oscillations at nominal gain	typ.	100 dB (μ V) into 75 Ω
Unwanted signal characteristics		
Image rejection (measured at picture carrier frequency)		
channels E21 to E60	min.	46 dB; typ. 53 dB
Harmonic content of oscillator sample; only valid for U342LO		
Suppression of harmonics which fall into the frequency range below 1200 MHz (second harmonics of fundamentals below 600 MHz)	min.	15 dB (typ. 20 dB) below oscillator fundamental
R.F. rejection at oscillator sample socket; only valid for U342LO		
Signal voltage at oscillator sample socket (input signals of wanted frequency 70 dB (μ V) into 75 Ω ; tuner operating at nominal gain)	min.	17 dB (typ. 24 to 34 dB) below oscillator fundamental
I.F. rejection (measured at picture carrier and colour sub-carrier frequency)	min.	60 dB
I.F. rejection at oscillator sample socket; only valid for U342LO		
I.F. signals at oscillator sample socket (converted from input signals of wanted frequency 70 dB (μ V) into 75 Ω ; tuner operating at nominal gain)	min.	20 dB (typ. 35 dB) below oscillator fundamental

N ± 4 rejection

Interference signal for an interference ratio of 53 dB referred to wanted picture carrier (picture to sound carrier ratio of 10 dB; wanted signal 60 dB(μV); tuner operating at nominal gain)

typ. 80 dB (μV) into 75 Ω

Cross modulation

Input signal producing 1% cross modulation, i.e. 1% of the modulation depth of the interfering signal is transferred to the wanted signal.

In channel cross modulation (wanted signal: picture carrier frequency; interfering signal: sound carrier frequency)

at nominal gain (wanted input level 60 dB (μV)) typ. 80 dB (μV) into 75 Ω

at 26 dB gain reduction (wanted input level 86 dB (μV)) typ. 100 dB (μV) into 75 Ω

In band cross modulation (wanted signal: picture carrier of channel N; interfering signal: picture carrier of channel N ± 5)

at nominal gain (wanted input level 60 dB (μV)) typ. 92 dB (μV) into 75 Ω

at 26 dB gain reduction (wanted input level 86 dB (μV)) typ. 100 dB (μV) into 75 Ω

Out of band cross modulation, at nominal gain

v.h.f. I min. 108 dB (μV) into 75 Ω

v.h.f. III min. 108 dB (μV) into 75 Ω

Oscillator characteristics

Pulling

Input signal of tuned frequency producing a shift of the oscillator frequency of 10 kHz, at nominal gain

typ. 80 dB (μV) into 75 Ω

Shift of oscillator frequency

at a change of the supply voltage of 5%

max. 550 kHz

Drift of oscillator frequency

during warm-up time (after the tuner has been completely out of operation for 15 min, measured between 5 s and 15 min after switching on)

max. 250 kHz

during warm-up time (after the input stage is in operation for 15 min, measured between 2 s and 15 min after switching on the oscillator/i.f. stage)

max. 250 kHz

at a change of the ambient temperature from +25 to +40 °C (measured after 3 cycles from +25 to +55 °C)

channels E21 to E60
channels E61 to E65
channels E66 to E69

U342	U342LO
max. 500 kHz	max. 500 kHz
max. 650 kHz	max. 800 kHz
max. 750 kHz	max. 1000 kHz

I.F. characteristics

Bandwidth of i.f. output circuit

$5^{+1}_{-0,5}$ MHz

Note: I.F. output of the tuner terminated with the circuit shown in Fig. 6; tuning voltage 15 V.

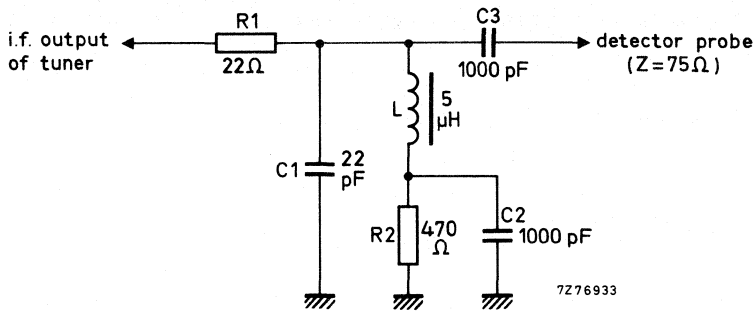

Fig. 6.

Bandwidth variation of i.f. output circuit as a result of r.f. tuning

max. 500 kHz

Note: I.F. output of the tuner terminated with a modified circuit of Fig. 6, i.e. a 100 pF capacitor is connected in parallel with C1; tuning voltage 15 V.

Detuning of the i.f. output circuit as a result of r.f. tuning

max. 500 kHz

Note: I.F. output of the tuner terminated with a modified circuit of Fig. 6, i.e. a 100 pF capacitor is connected in parallel with C1; tuning voltage 15 V.

Minimum tuning range of i.f. output coil

33 to 40 MHz

Note: I.F. output of the tuner terminated with the circuit shown in Fig. 6; tuning voltage 15 V.

Attenuation between i.f. injection point and i.f. output of the tuner

typ. 23 ± 3 dB

Miscellaneous

Radio interference

Oscillator radiation and oscillator voltage at the aerial terminal

Within the limits of C.I.S.P.R. 13 (1975) and VDE 0872/7.72*

Microphonics

There will be no microphonics, provided the tuner is installed in a professional manner.

Surge protection

Protection against voltages

max. 5 kV

Note: Three discharges of a 470 pF capacitor into the aerial terminal.

Protection against flashes

max. 30 kV, 400 mWs

Note: A flashover circuit producing flashes with frequencies of 1 to 20 Hz for 30 s is connected to the aerial terminal.

* For U342LO: when the oscillator sample socket is either open or terminated with a coaxial plug (75Ω impedance, e.g. type 3/2-50, Daut und Rietz).

ADDITIONAL INFORMATION

I.F. injection

The tuner is provided with an i.f. injection point at the collector of the i.f. transistor (coupled via a small capacitor to terminal 7). The i.f. generator can be connected directly to this point (Fig. 7). The tuner needs normal supply voltages and a tuning voltage of 15 V; the i.f. output should be loaded with the circuit shown in Fig. 6.

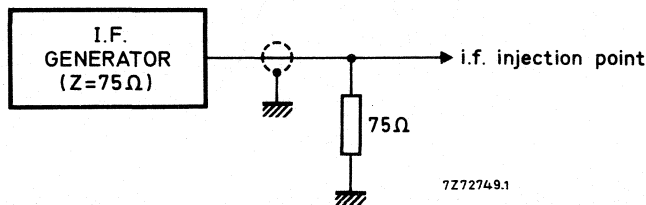

Fig. 7.

Connection of the i.f. amplifier

The tuner needs a d.c. path from the i.f. output terminal (10) to earth, preferably via a choke of approx. $5\ \mu\text{H}$ outside the tuner (Fig. 8). Where the tuner is used in combination with a v.h.f. tuner, this choke can be common for both tuners; a resistor in series with the choke can make ineffective the i.f. output circuit of the switched-off tuner. For damping the i.f. output circuit and matching the i.f. output impedance of the tuner to the i.f. amplifier, a series resistor and a parallel capacitor as shown in Fig. 8 should be used.

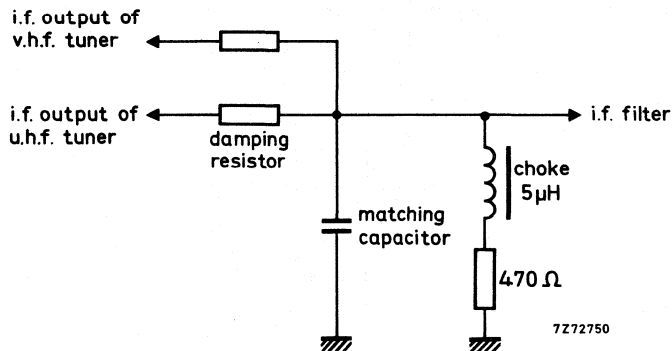

Fig. 8.

Measuring method of power gain

The i.f. output of the tuner should be terminated with the RC-circuit given in Fig. 6.

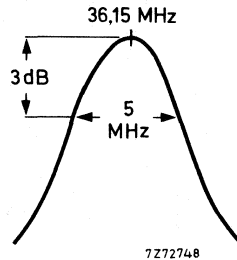

Fig. 9.

The RC-circuit roughly matches the i.f. output impedance to 75Ω at the resonant frequency of the i.f. output circuit, which should be tuned to 36,15 MHz; the bandwidth should be approx. 5 MHz (Fig. 9).

Because the input and output impedances of the tuner are now 75Ω , the power gain can be measured in the conventional manner by inserting tuner and RC-circuit between a 75Ω source and a 75Ω detector.

Alignment of the i.f. output coil

The i.f. output coil should be adjusted with a brass tool with a blade as shown in Fig. 10. A suitable tool is available under catalogue number 7122 005 47680.

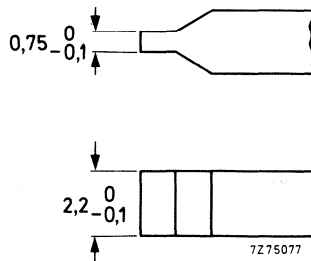

Fig. 10.

ACCESSORIES

Connector assembly for use of tuner U342 or U342LO in combination with v.h.f. tuner V317 or V334:
connector, catalogue number 3112 200 20720;
washer, catalogue number 3112 221 01220;
clamp, catalogue number 3112 274 13220.

U.H.F. TELEVISION TUNERS

QUICK REFERENCE DATA

Systems	C.C.I.R. systems I (United Kingdom), G and H	
Channels	E21 to E69	
	<u>system I</u>	<u>systems G and H</u>
Intermediate frequencies		
picture	39.5 MHz	38.9 MHz
sound	33.5 MHz	33.4 MHz

APPLICATION

Tuners U343 and U344 are further developments of tuner U341 Mark 2. The U343 is identical to the U344 but without frequency divider, necessary to drive digital tuning systems.

They are meant for use in u.h.f. single standard receivers and have been designed to drive an i.f. surface acoustic wave (SAW) filter. For this purpose the tuners have been provided with a doubled tuned i.f. filter with post-amplifier to compensate for the losses of the SAW filter.

The pinning arrangements of the tuners are compatible with tuner U341 Mark 2 for pins 2, 3, 4, 6 and 10 but differ for pins 7, 8 and 9.

SURVEY OF TYPES

tuner type	code number	aerial socket	frequency divider
U344	3122 127 37390	phono	256
U344/IEC	3122 127 36700	IEC	256
U343	3122 127 37520	phono	—
U343/IEC	3122 127 37220	IEC	—

Tuners U343/IEC and U344/IEC are identical to tuners U343 and U344 respectively, but with an IEC aerial socket which meets the IEC 169-2 requirements. It is recommended that plugs which comply with this standard are used.

DESCRIPTION

The tuners are u.h.f. tuners with electronic tuning covering the u.h.f. band from 470 to 860 MHz (channels E21 to E69).

Mechanically the tuners are built on a printed-wiring board and enclosed in a metal housing, comprising a rectangular frame and front and rear covers (see Fig.2). The aerial connection (phono or IEC) is on one of the frame sides, the supply voltage and i.f. connections are on the bottom side and the i.f. injection point on the top side.

Electrically the tuners consist of an input circuit with a high-pass characteristic and a MOS-FET tetrode BF980. The tetrode acts as an r.f. amplifier and as an a.g.c. device controlled by an a.g.c. voltage, fed to gate 2. The drain of the MOS-FET is connected to a double tuned circuit which transfers the signal to the mixer Schottky diode 1SS99. The r.f. selectivity of this circuit at the image frequency has been improved by special means. The mixer diode is driven by an oscillator transistor BF970. The i.f. signal from the mixer is amplified by a transistor BF324, followed by a double-tuned i.f. band-pass filter and a BF370 post-amplifier.

The combination of the Schottky-barrier diode 1SS99 and the i.f. post-amplifier ensures good noise figures and signal handling properties.

Three capacitance diodes OF643 tune the r.f. band-pass filter and oscillator circuit.

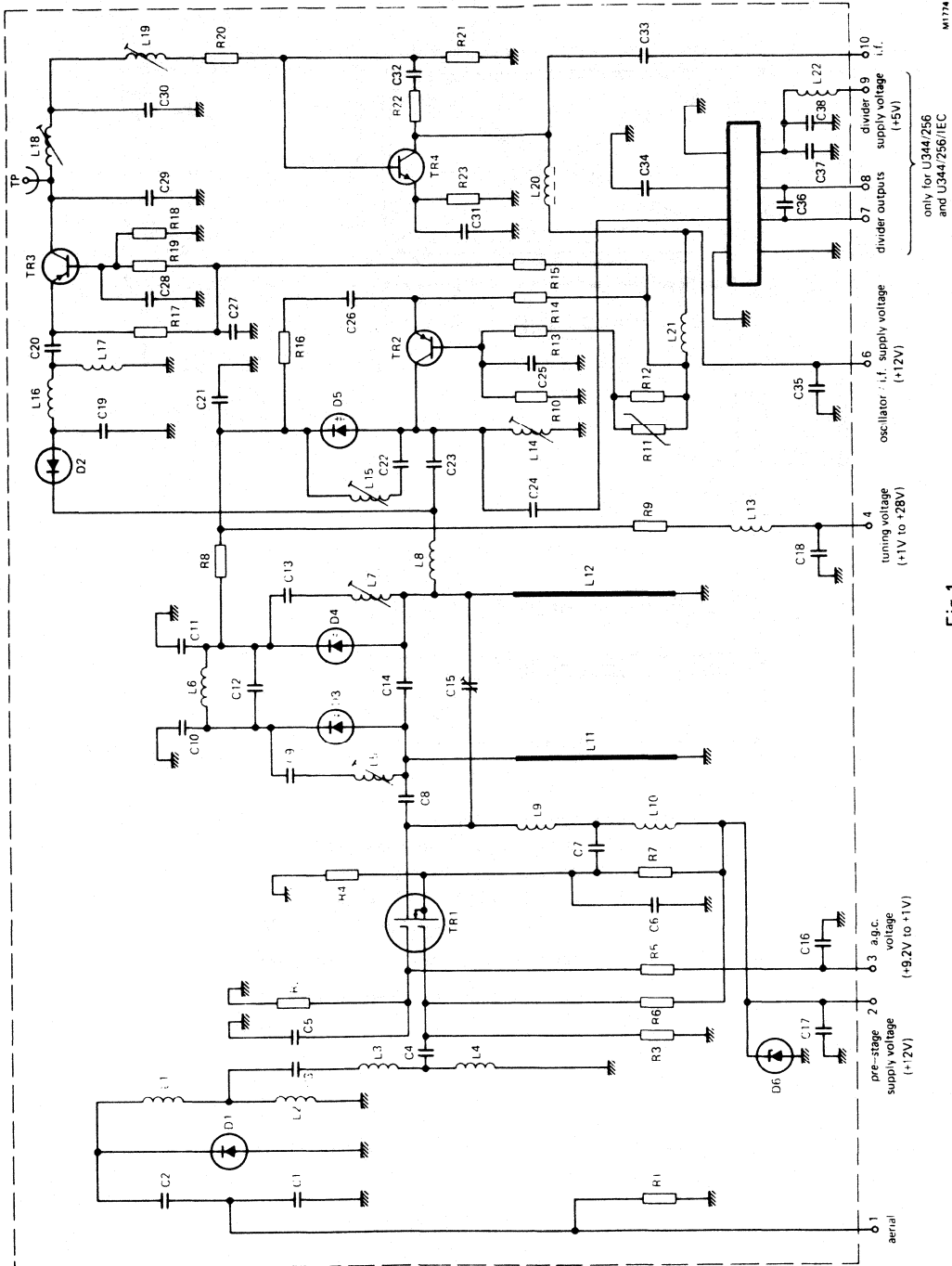

W1774

Fig.1

U343
U344

MECHANICAL DATA

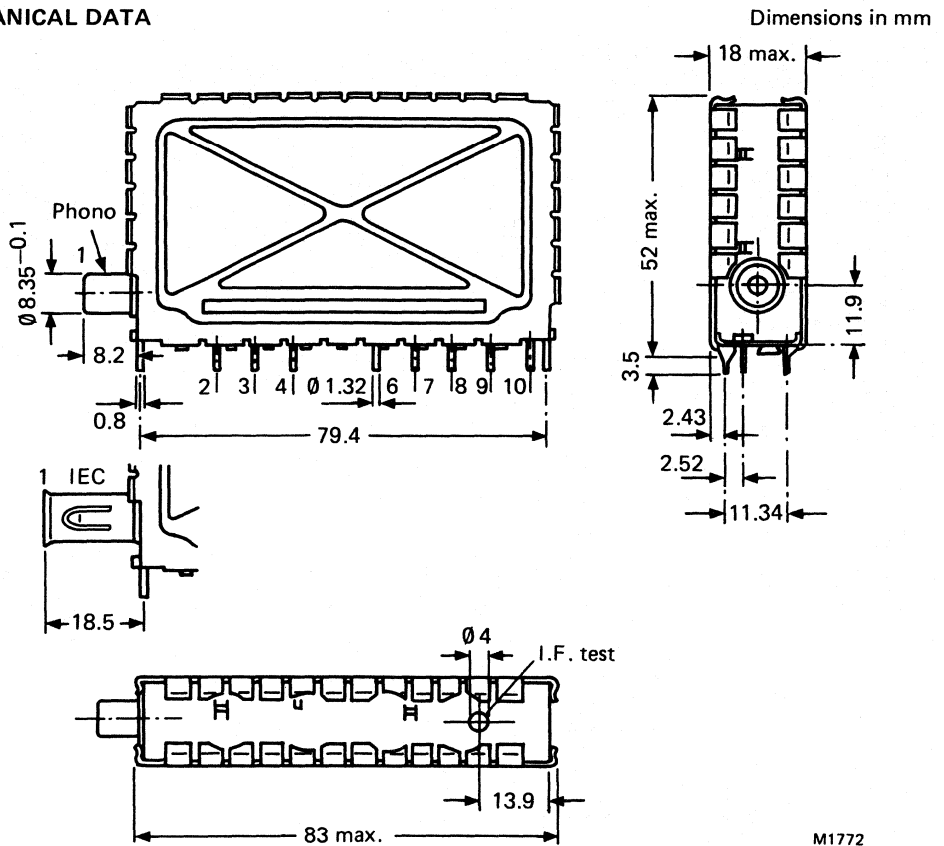

M1772

Fig.2

- Terminal 1 = aerial connection
- 2 = supply voltage, pre-stage, +12 V
- 3 = a.g.c. voltage, +9.2 to +1 V
- 4 = tuning voltage, +1 to +28 V
- 6 = oscillator/i.f. supply voltage, +12 V
- 7 = balanced frequency divider output*
- 8 = supply voltage frequency divider, +5 V*
- 9 = supply voltage frequency divider, +5 V*
- 10 = i.f. output

*only for U344/256 and U344/256/IEC

Mass approx. 75g

Mounting

The tuner may be mounted by soldering it on to a printed-wiring board with connections as shown by the piercing diagram in Fig.3.

It is recommended that the tuner be installed in a cool part of the receiver cabinet and not exposed to the vibrations of the loudspeaker. There are no restrictions on orientation.

The solderability of the terminals and mounting tabs is according to IEC 68-2, test Ta ($230 \pm 10 \text{ }^\circ\text{C}$, $2 \pm 0.5 \text{ s}$). The resistance to soldering heat is according to IEC 68-2, test Tb ($260 \pm 5 \text{ }^\circ\text{C}$, $10 \pm 1 \text{ s}$).

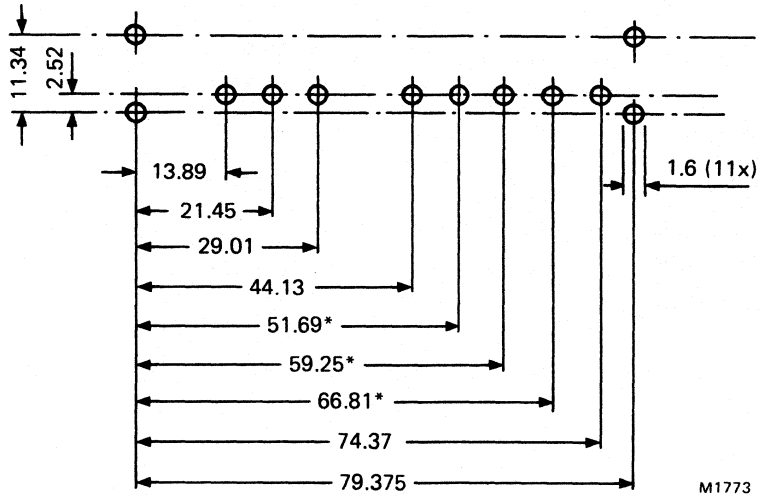

*only for U344/256 and U344/256/IEC

Fig.3 Piercing diagram viewed from solder side of board.

In cold chasses where no mains isolation is required the tuner is situated such that the IEC serial socket projects beyond the back plate of the cabinet. Direct access from the aerial cable to the tuner input is then possible. In that case it is advised to provide the tuner with a stress relief around the aerial socket fixed to the set frame.

ELECTRICAL DATA

Unless otherwise specified all electrical values apply at an ambient temperature of 25 ± 5 °C, a relative humidity of $60 \pm 15\%$, a supply voltage of 12 ± 0.3 V, an a.g.c. voltage of 9.2 ± 0.2 V, and a divider supply voltage of 5 ± 0.2 V.

Within the given tolerance range of supply voltage and a.g.c. voltage only insignificant deviations from the specified values can be expected. Under the extreme conditions of temperature and humidity as given below, the tuner will function normally, but some specified limits may be exceeded.

General

Semiconductors

r.f. amplifier	BF980
mixer diode	1SS99
oscillator	BF970
tuning diodes	3 x OF643
i.f. pre-amplifier	BF324
i.f. post-amplifier	BF370
frequency divider	SP4653
surge protection diode	BAV10
surge protection diode	OF719

Ambient temperature range

operating	-10 to +60 °C
storage	-25 to +85 °C

Relative humidity

max. 90%

Voltages and currents

Supply voltage	+12 V \pm 10% (+10%, -15%)
----------------	------------------------------

Note: Supply voltages of +12 V -15% are admissible if a deterioration of gain, noise figure, signal handling, oscillator shift and drift is accepted. In this case the min. a.g.c. voltage has to be decreased to 0.8 V to cover the specified a.g.c. range.

Ripple susceptibility

Defined as the peak-to-peak value of a sine wave signal (20 Hz - 500 kHz) on the supply voltages causing an amplitude modulation with a modulation depth of 0.28% on the picture carrier after passing the Nyquist curve of the i.f. filter of a tv receiver.

ripple susceptibility	min. 3 mV peak-to-peak
-----------------------	------------------------

Current drawn from +12 V supply

r.f. amplifier, at nominal gain	max.	21	mA
r.f. amplifier, at 30 dB gain reduction	typ.	11	mA
oscillator/i.f. amplifier	max.	36	mA

A.G.C. voltage (Fig.4)

voltage at nominal gain	+9.2 \pm 0.5	V
voltage at 30 dB gain reduction	min.	+1 V

Note: A.G.C. voltages between 0 and +10.5 V may be applied without risk of damage.

A.G.C. current (Fig.4)

during gain control (0 to 30 dB)	max.	+15	μ A
at nominal gain	typ.	+11	μ A

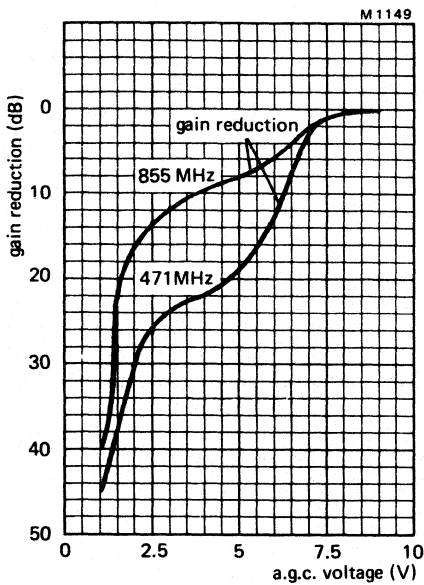

Fig.4

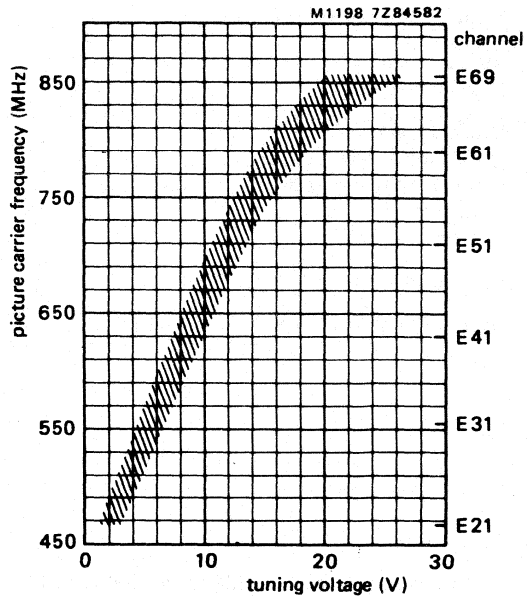

Fig.5

Tuning voltage range (Fig.5)

+1 to +28 V

Current drawn from +28 V tuning voltage supply

at 25 °C

max. 0.15 μ A

at 60 °C

max. 0.6 μ A

at 25 °C (relative humidity 95%)

max. 0.6 μ A

Slope of tuning characteristic

min. 4 MHz/V

Frequencies

Frequency range

channel E21 (picture carrier 471.25 MHz)
to channel E69 (picture carrier 855.25 MHz).
Margin at the extreme channels: min. 3 MHz.

Intermediate frequencies

picture

system I	systems G, H
39.5 MHz	38.9 MHz
33.5 MHz	33.4 MHz

sound

The oscillator frequency is higher than the aerial signal frequency.

Note: The tuner is aligned in such a way that the i.f. frequencies of the three systems can be applied.

Wanted signal characteristics

Input impedance asymmetrical	75 Ω
V.S.W.R. and reflection coefficient at picture carrier frequency, at nominal gain and at 30 dB gain reduction v.s.w.r. reflection coefficient	max. 6 max. 71%
R.F. bandwidth	typ. 20 MHz
Overall curves, tilt R.F. in – I.F. out	on any channel the amplitude difference between the top of the overall curve and the picture carrier, the sound carrier, or any frequency between them will not exceed 3 dB at nominal gain, and 4 dB in the a.g.c. range between nominal gain and 20 dB gain reduction.
A.G.C. range	min. 30 dB
Voltage gain (i.f. load = 1200 Ω in parallel to 15 pF) channel E21 channel E40 channel E69	min. 40 dB typ. 49 dB typ. 47 dB typ. 49 dB
Gain difference between any two channels	typ. 4 dB
Noise figure channel E21 channel E40 channel E69	max. 10 dB typ. 6.0 dB typ. 6.5 dB typ. 7.5 dB
Overloading	
Input signal producing 1 dB gain compression at nominal gain	typ. 88 dB (μ V) into 75 Ω
Input signal producing either a detuning of the oscillator of +300 kHz or –1000 kHz or stopping of the oscillations at nominal gain	typ. 100 dB (μ V) into 75 Ω
1.6 MHz moiré rejection (for i.f. 39.5/33.5 MHz)	
Wanted signal level of a tv signal (picture to sound ratio of 7 dB and picture to chroma ratio of 16 dB), which produces an unwanted i.f. component (37.8 MHz) 52 dB below the i.f. picture carrier, when the tuner is 30 dB gain controlled.	
tv signal (picture carrier)	typ. 100 dB (μ V) into 75 Ω

Unwanted signal characteristics

Image rejection (measured at picture carrier frequency)

at nominal gain, channels E21 to E60	min.	53 dB; typ. 60 dB
at 20 dB gain reduction, channels E21 to E60	min.	50 dB; typ. 55 dB

I.F. rejection (measured at picture carrier and colour sub-carrier frequency)

min.	80 dB
------	-------

1st repeat spot rejection (for i.f. 39.5/33.5 MHz)

Defined as the input level of the picture carrier of channel $N + 2$, the sound carrier of which produces an i.f. signal (35.0 MHz), which is 52 dB below the picture carrier of the wanted signal N (picture to sound ratio 7 dB; wanted signal 60 dB (μV), tuner operating at nominal gain.

interfering signal	typ.	80 dB (μV) into 75 Ω
--------------------	------	--

$N \pm 4$ rejection

Interference signal for an interference ratio of 53 dB referred to wanted picture carrier (picture to sound carrier ratio of 7 dB; wanted signal 60 dB (μV); tuner operating at nominal gain)

$N + 4$ rejection	typ.	80 dB (μV) into 75 Ω
$N - 4$ rejection	typ.	78 dB (μV) into 75 Ω

Cross modulation

Input signal producing 1% cross modulation, i.e. 1% of the modulation depth of the interfering signal is transferred to the wanted signal.

In channel cross modulation (wanted signal: picture carrier frequency; interfering signal; sound carrier frequency)

at nominal gain (wanted input level 60 dB (μV))	typ.	80 dB (μV) into 75 Ω
at 26 dB gain reduction (wanted input level 86 dB (μV))	typ.	94 dB (μV) into 75 Ω

In band cross modulation (wanted signal: picture carrier of channel N ; interfering signal: picture carrier of channel $N \pm 5$).

at nominal gain (wanted input level 60 dB (μV))	typ.	92 dB (μV) into 75 Ω
at 26 dB gain reduction (wanted input level 86 dB (μV))	typ.	95 dB (μV) into 75 Ω

Out of band modulation, at nominal gain

v.h.f. I	min.	108 dB (μV) into 75 Ω
v.h.f. III	min.	108 dB (μV) into 75 Ω

Unwanted signal handling capability

The tuner operates together with a standard tv receiver with normal A.G.C. for tuner and i.f. amplifier. Unwanted tv signal 3 channels higher or lower than wanted. Unwanted signal level adjusted for just not visible interference.

Unwanted picture carrier signal	typ.	96 dB (μV)
---------------------------------	------	-------------------------

Oscillator characteristic

Pulling

Input signal of tuned frequency producing a shift of the oscillator frequency of 10 kHz, at nominal gain typ. 85 dB (μ V) into a 75 Ω

Shift of oscillator frequency (Δ F) at a change of the supply voltage of 5% max. 500 kHz

Drift of oscillator frequency during warm-up time (after the tuner has been completely out of operation for 15 min, measured between 5 s and 15 min after switching on) max. 250 kHz

at a change of the ambient temperature from +25 to +50 $^{\circ}$ C and +25 $^{\circ}$ C to 0 $^{\circ}$ C (measured after 3 cycles from +25 to +55 $^{\circ}$ C) channels E21 to E69 max. 1000 kHz

at a change of humidity from 60% \pm 15% to 93% \pm 2% measured at T_{amb} 25 $^{\circ}$ C \pm 5 $^{\circ}$ C, max. 1500 kHz

I.F. characteristics

Bandwidth of i.f. output circuit typ. 11 MHz

Note: I.F. output of the tuner terminated with the circuit shown in Fig.7, tuning voltage 10 V.

IF output impedance approx. 100 Ω

Attenuation from i.f. injection point to tuner i.f. output typ. 16 dB

Frequency divider characteristics

Values valid in the tuning voltage range 0.5 to 30 V

Supply voltage 5 V \pm 10%

Supply current max. 35 mA

Output voltages (probe 10 M Ω //11 pF)
open voltage, pin 7 min. 0.5 V peak-to-peak
open voltage, pin 8 min. 0.5 V peak-to-peak

Output unbalance max. 0.1 V

Signal to interference ratio at an aerial input level of 100 μ V min. 46 dB

Miscellaneous

Radio interference

Oscillator radiation and oscillator voltage at the aerial terminal

Within the limits of C.I.S.P.R. 13 (1975).
Use is made of the relaxed limit of 3 mV/m (70 dB (μ V/m)).

Immunity from radiated interference

Aerial terminal meets requirements of BS905, provided the aerial cable is connected in a professional manner.

Microphonics

There will be no microphonics, provided the tuner is installed in a professional manner.

Surge protection

Protection against voltages

max. 5 kV



Note: Ten discharges of a 470 pF capacitor into the aerial terminal.

Protection against flashes

min. 30 kV, 400 mWs

Note: A flashover circuit producing flashes with frequencies of 1 to 20 Hz for 30 s is connected to the aerial terminal.

E.S.D. protection

min. 2 kV

Note: acc. to MIL STD 003C

ADDITIONAL INFORMATION

I.F. injection

The tuner has an i.f. injection point at the collector of BF324 i.f. transistor located at the top side of the tuner. The i.f. generator can be connected directly to this point (Fig.6), via a 0.3 pF capacitor. The tuner needs normal supply voltages and a tuning voltage of 15 V. A probe according to Fig.6 is available under code 7622 468 17940.

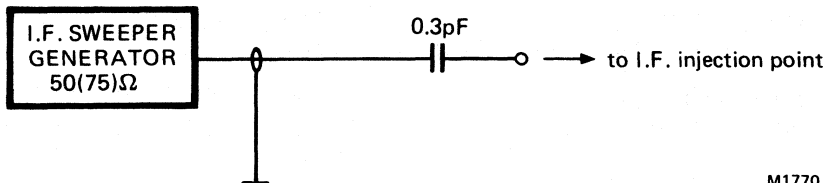

M1770

Fig.6

Voltage gain

Since the r.f. input and the i.f. output load impedances differ, the gain of the U343 U344 tuners are expressed in terms of voltage gain. It is defined as the ratio between the i.f. output and the corresponding r.f. input voltage.

The i.f. output of the tuner is loaded with an impedance of 1200 Ω in parallel with a 15 pF capacitor representing a standard replacement of the input impedance of a SAW filter.

To be able to carry out tuner measurements with existing 75 Ω equipment a matching circuit is connected to the i.f. output of the tuner. The input gives the required load to the tuner output while the output represents a source impedance suitable to connect to standard 75 Ω equipment, see Fig.7.

Total losses of the circuit are 26 dB.

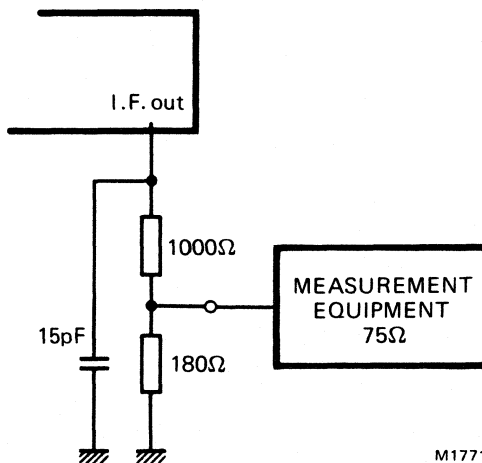

M1771

Fig.7

U.H.F. TELEVISION TUNERS

QUICK REFERENCE DATA

Systems	C.C.I.R. systems I (United Kingdom), G, H and K	
Channels	E21 to E69	
Intermediate frequencies	systems G and H	systems I and K
picture	38,9 MHz	39,5 MHz
sound	33,4 MHz	33,5 MHz

APPLICATION

Designed to cover the u.h.f. channels of C.C.I.R. systems I, G, H and K in u.h.f. single standard receivers. They meet the special requirements of the United Kingdom. The tuners of the U412 series are equipped with a frequency divider, which makes them suitable for digital tuning systems based on frequency synthesis; for the remainder they are equal to type U411.

Available versions

	aerial input connector	frequency divider (IC)	division ratio	catalogue number
U411	phono	—		3112 218 51790
U411/IEC	IEC	—		3112 218 52400
U412/256	phono	8-pin	256	3112 218 51810
U412/256/IEC	IEC	8-pin	256	3112 218 52410
U412/64	phono	8-pin	64	3112 218 52290
U412/64/IEC	IEC	8-pin	64	3112 218 52420

U411 SERIES U412 SERIES

DESCRIPTION

The U411 and U412 are u.h.f. tuners with electronic tuning. They meet the special requirements of the United Kingdom and are pin-compatible with the UV411, UV417 and the UV412 and UV418 respectively. Mechanically, the tuners are built on a low-loss printed-wiring board, carrying all components, in a metal housing made of a rectangular frame and front and rear covers (see Fig. 2a). The coaxial aerial connector (phono or IEC) of 75Ω is on one of the frame sides, all other connections (supply voltages, a.g.c. voltage, tuning voltage, i.f. output) are made via terminals in the underside. The mounting method is shown in Fig. 3.

Electrically (see Fig. 1), the tuners consist of a bandpass input circuit connected to gate 1 of an input MOSFET tetrode (with internal gate protection against surge). The drain load of this MOSFET tetrode is formed by a double tuned circuit transferring the r.f. signal to the Schottky barrier mixer diode.

The selectivity of this circuit at the image frequency is such that it meets the stringent requirements of the U.K.

The i.f. signal from the mixer is amplified by an i.f. transistor connected in grounded-base configuration. The combination of Schottky barrier diode and i.f. transistor ensures good noise figures and good signal handling properties.

The double tuned circuit and the oscillator circuit are tuned by 3 BB405B capacitance diodes. The i.f. output circuit of the tuner is a single tuned circuit, at the low end of which the i.f. signal is coupled out of the tuner. A test point (terminal 4) is provided for i.f. injection to align the i.f. output circuit of the tuner together with the i.f. amplifier of the television receiver. An additional test point, which is accessible through a hole in the top of the tuner, is connected to the collector of the i.f. amplifier transistor. The tuner is gain controlled via gate 2 of the input MOSFET tetrode.

The electrical circuit of the U412 series is extended with a frequency divider (division ratio of 64 or 256) the inputs of which are connected to the oscillator. The outputs are balanced; they are connected to terminals 12 and 13.

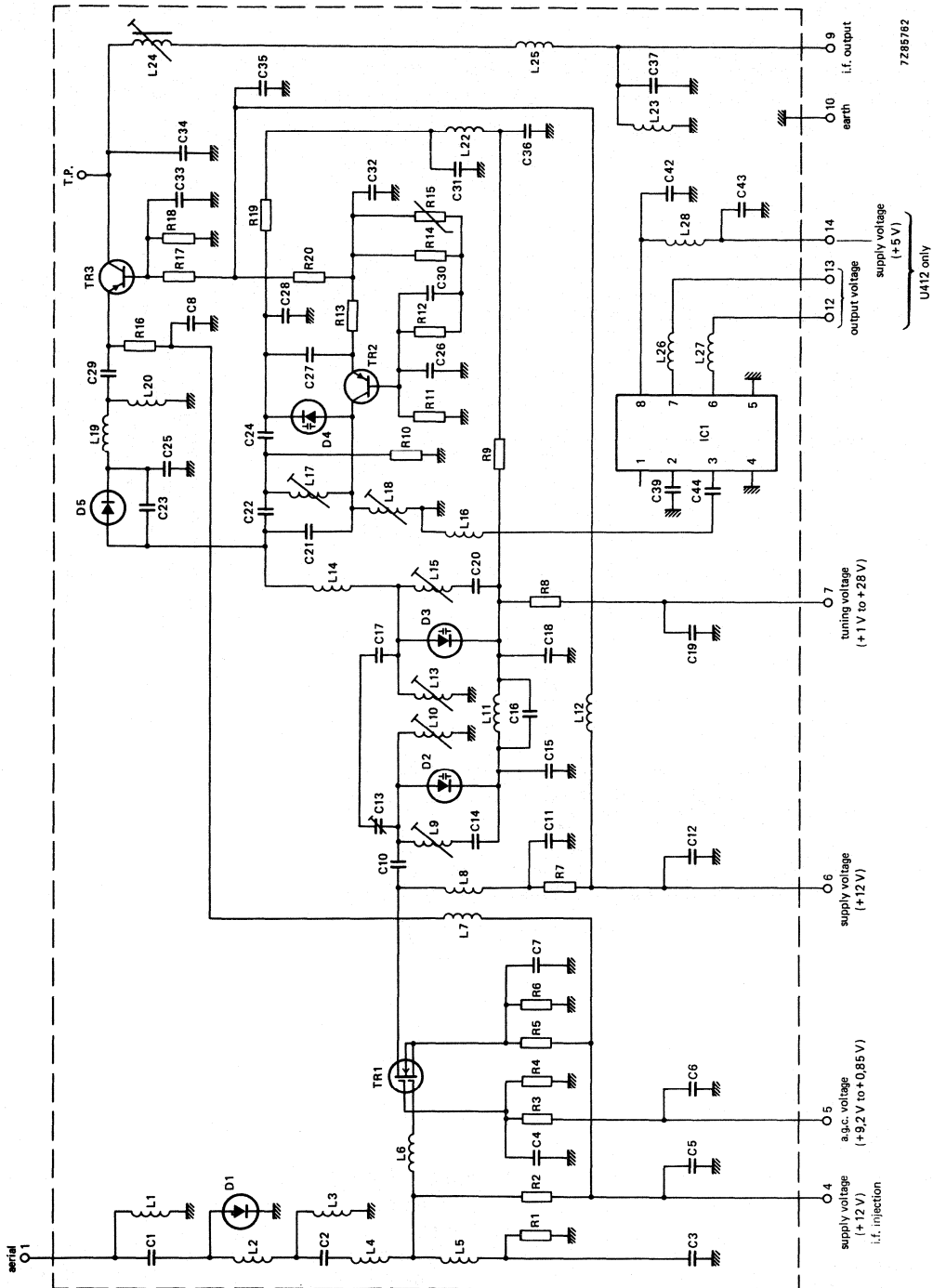
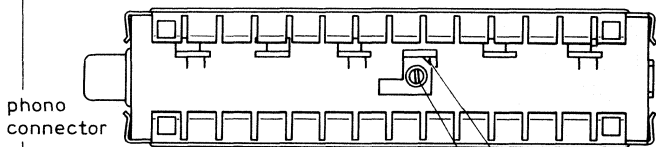
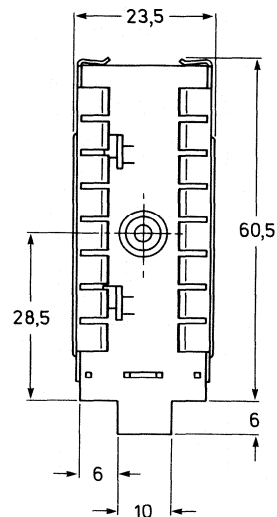
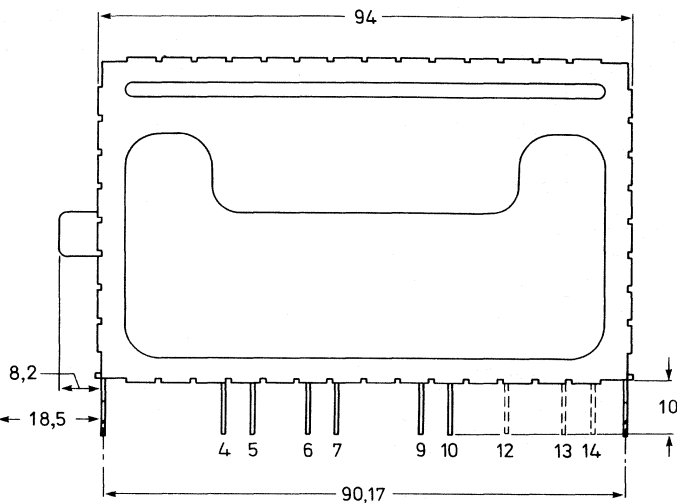
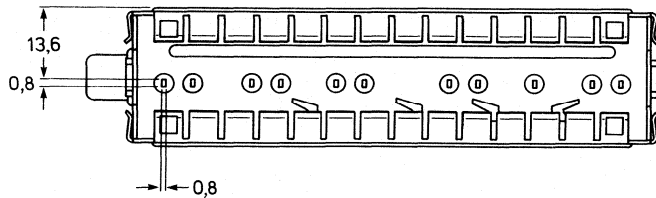

Fig. 1.

U411 SERIES U412 SERIES

MECHANICAL DATA

Dimensions in mm



phono connector

test point
i.f. coil

7Z85763.1

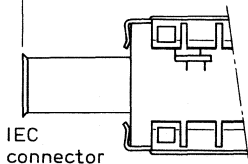

IEC connector

Fig. 2a.

Terminal

- 1 = aerial
- 4 = supply voltage, + 12 V; i.f. injection
- 5 = a.g.c. voltage, + 9,2 to 0,85 V
- 6 = supply voltage, + 12 V

- 7 = tuning voltage, + 1 to + 28 V
 - 9 = i.f. output
 - 10 = earth
 - 12, 13 = balanced output voltage of frequency divider
 - 14 = supply voltage, frequency divider, + 5 V
- } only for U412

Fig. 2b I.F. output coil.
Torque for alignment: 2 to 15 mNm.
Press-through force: ≥ 10 N.

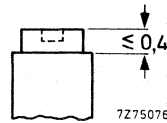

Mass approx. 99 g

Mounting

The tuner may be mounted by soldering it on to a printed-wiring board, using the piercing diagram shown in Fig. 3. The tuner may be mounted anywhere in the receiver and there are no restrictions on orientation. However it is recommended that it is placed in the cool part of the cabinet and away from loudspeaker vibrations.

The solderability of the terminals and mounting tabs (except cut edges) is according to IEC 68-2, test Ta (230 ± 10 °C, $2 \pm 0,5$ s). The resistance to soldering heat is according to IEC 68-2, test Tb (260 ± 5 °C, 10 ± 1 s).

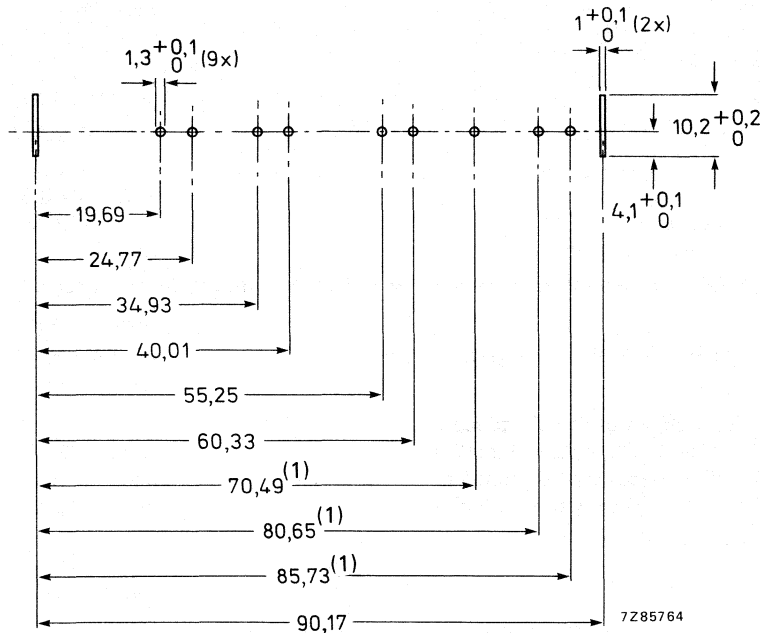

Dimensions in mm

(1) only for U412.

Fig. 3 Piercing diagram viewed from solder side of board. Unless otherwise stated the tolerance is $\pm 0,05$ mm.

ELECTRICAL DATA

Unless otherwise specified all electrical values apply at an ambient temperature of 25 ± 5 °C, a relative humidity of $60 \pm 15\%$, a supply voltage of $12 \pm 0,3$ V and an a.g.c. voltage of $9,2 \pm 0,2$ V.

General

Semiconductors

r.f. input MOSFET transistor	BF980 (3SK87)
oscillator transistor	BF970
i.f. amplifier transistor	BF324
mixer diode	1SS99
tuning diodes	3 x BB405B
surge protection diode	BAV10
frequency divider	SP4653 or SP4632

Ambient temperature range

operating	0 to + 55 °C
storage	-25 to + 70 °C

Relative humidity

max. 95%

Voltages and currents

Supply voltage

+ 12 V \pm 10%

Current drawn from + 12 V supply

max. 45 mA; typ. 34 mA

A.G.C. voltage

voltage range	+ 9,2 to + 0,85 V
voltage at nominal gain	+ 9,2 \pm 0,5 V
voltage at 30 dB gain reduction	min. 1 V

Note: A.G.C. voltages between 0 and + 10,5 V may be applied without risk of damage.

A.G.C. current

max. 0,2 mA

Slope of a.g.c. characteristic at end of specified range

typ. 50 dB/V

Tuning voltage range

+ 1 to + 28 V

Current drawn from 28 V tuning voltage supply

at $T_{amb} = 25$ °C and 60% relative humidity	max. 0,25 μ A
at $T_{amb} = 25$ °C and 95% relative humidity	max. 1,0 μ A
at $T_{amb} = 55$ °C and 60% relative humidity	max. 1,0 μ A

Slope of tuning characteristic

channel E21	typ. 22 MHz/V
channel E69	typ. 5 MHz/V

Note: the source impedance of the tuning voltage must be maximum 47 k Ω .

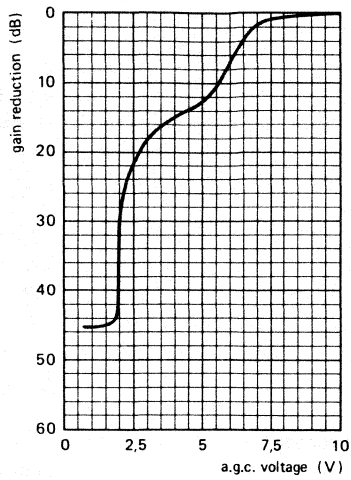

Fig. 4 Typical a.g.c. characteristics, bands IV and V.

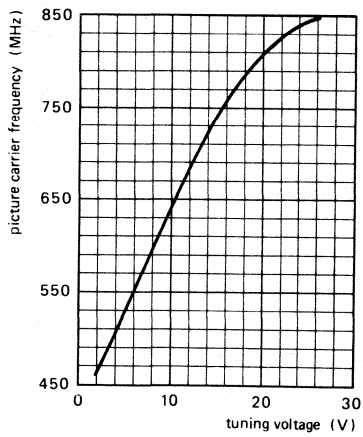

Fig. 5 Typical tuning characteristic, bands IV and V.

U411 SERIES U412 SERIES

Frequencies

Frequency range
bands IV and V

Intermediate frequencies
picture
sound

Wanted signal characteristics

Input impedance

V.S.W.R. and reflection coefficient
(values between picture and sound carrier,
as well as values at picture carrier)

v.s.w.r.
reflection coefficient

R.F. curves, bandwidth

R.F. curves, tilt

A.G.C. range

Power gain

Maximum gain difference between any two channels

Noise figure

Overloading:

Input signal producing 1 dB gain compression
at nominal gain

Input signal producing either a detuning of the oscillator
of + 300 kHz or -1000 kHz or stopping of the
oscillations at nominal gain

Unwanted signal characteristics

Image rejection (measured at picture carrier frequency)

I.F. rejection (measured at picture carrier frequency)

Channel E21 (picture carrier
471,25 MHz) to channel E69 (picture
carrier 855,25 MHz). Margin at the
extreme channels: min. 3 MHz.

systems G and H	systems I and K
38,9 MHz	39,5 MHz
33,4 MHz	33,5 MHz

The oscillator frequency is higher than
the aerial signal frequency.

75 Ω

at nominal gain	during gain control
max. 5	max. 6
max. 66%	max. 71%

typ. 24 MHz

on any channel the amplitude
difference between the top of the
r.f. resonant curve and either the
picture frequency, or the sound
frequency, or any frequency between
them will not exceed 3 dB at nominal
gain, and 4 dB in the a.g.c. range
between nominal gain and 20 dB gain
reduction.

min. 30 dB

min. 20 dB

typ. 4 dB

max. 10 dB

typ. 90 dB (μ V) into 75 Ω

typ. 100 dB (μ V) into 75 Ω

min. 53 dB; typ. 50 dB

min. 60 dB

$N \pm 4$ rejection

Interference signal for an interference ratio of 53 dB referred to wanted picture carrier (picture to sound carrier ratio of 7 dB; wanted signal 60 dB (μV); tuner operating at nominal gain)

interfering signal $N + 4$

typ. 80 dB (μV) into 75 Ω

interfering signal $N - 4$

typ. 73 dB (μV) into 75 Ω

Cross modulation:

Input signal producing 1% cross modulation, i.e. 1% of the modulation depth of the interfering signal is transferred to the wanted signal

Out of band modulation at nominal gain

v.h.f. I

typ. 108 dB (μV) into 75 Ω

v.h.f. III

typ. 108 dB (μV) into 75 Ω

Oscillator characteristics

Pulling:

Input signal of tuned frequency producing a shift of the oscillator frequency of 10 kHz, at nominal gain

typ. 80 dB (μV) into 75 Ω

Shift of oscillator frequency at a change of the voltage of 5%

max. 500 kHz

Drift of oscillator frequency during warm-up time (after the tuner has been completely out of operation for 15 min, measured between 5 s and 15 min after switching on).

max. 250 kHz

Drift of oscillator frequency at a change of the ambient temperature from + 25 to + 50 $^{\circ}\text{C}$ (measured after 3 cycles from + 25 to + 55 $^{\circ}\text{C}$)

max. 1000 kHz

Frequency divider characteristics of the U412/64 and U412/256 versions

Supply voltage

+ 5 V \pm 5%

Current drawn from + 5 V supply

max. 35 mA; typ. 25 mA

Output voltage, unloaded, measured with probe 10 M Ω /11 pF

min. 0,7 V p-p

Output impedance

typ. 1 k Ω

Output imbalance

typ. 0,1 V

Interference signal on the i.f. output

U412/256

max. 3 μV

U412/64

max. 20 μV

Note: I.F. output of the tuner terminated with the circuit shown in Fig. 6.

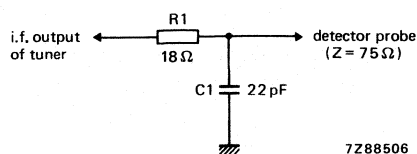

Fig. 6.

I.F. circuit characteristics

Bandwidth of i.f. output circuit

5 ± 1 MHz

Note: I.F. output of the tuner terminated with the circuit shown in Fig. 6, tuning voltage 15 V.

Bandwidth variation of i.f. output circuit as a result of r.f. tuning; tuning voltage 15 V

max. 500 kHz

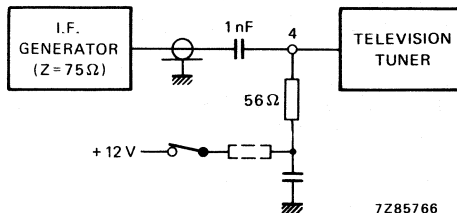

Fig. 7.

Attenuation between i.f. injection point and i.f. output of the tuner

typ. 18 dB

Miscellaneous

Radio interference:

Oscillator radiation and oscillator voltage at the aerial terminal

Within the limits of C.I.S.P.R. 13 (1975)

Immunity from radiated interference

Meets the limits of BS905 (1969) with a reserve of at least 5 dB

Microphonics

There will be no microphonics, provided the tuner is installed in a professional manner.

Surge protection:

Protection against voltages

max. 5 kV

Note: 10 discharges of a 470 pF capacitor into the aerial terminal.

Protection against flashes

max. 30 kV, 400 mWs

Note: A flashover circuit producing flashes with frequencies of 1 to 20 Hz for 30 s is connected to the aerial terminal.

ADDITIONAL INFORMATION

I.F. injection

Terminal 4 (supply voltage) can be used as i.f. injection point, provided the supply voltage is applied to terminal 4 via a resistor of 10 Ω (see Fig. 8). The tuning voltage should be 15 V.

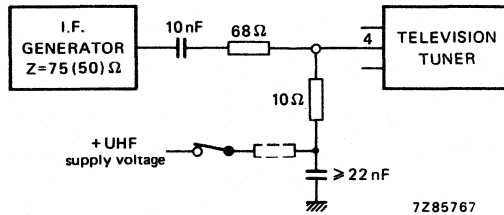

Fig. 8.

Connection of the i.f. amplifier

Connection to the i.f. amplifier should be either by a printed connection of minimum length or by a shielded connection such as a coaxial cable.

Measuring method of power gain

The i.f. output of the tuner should be terminated with the RC-circuit given in Fig. 6.

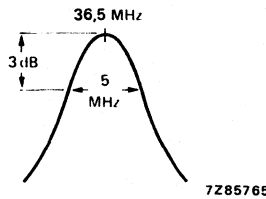

Fig. 9.

The RC-circuit roughly matches the i.f. output impedance to 75Ω at the resonant frequency of the i.f. output circuit, which should be tuned to 36,5 MHz; the bandwidth is approx. 5 MHz (Fig. 9). Because the input and output impedances of the tuner are now 75Ω , the power gain can be measured in the conventional manner by inserting tuner and RC-circuit between a 75Ω source and a 75Ω detector.

Alignment of the i.f. output coil

The i.f. output coil should be adjusted with a brass tool with a blade as shown in Fig. 10. A suitable tool is available under catalogue number 7122 005 47680.

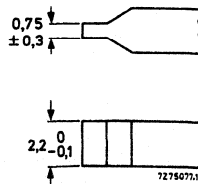

Fig. 10.

U.H.F. TELEVISION TUNERS

QUICK REFERENCE DATA

Systems	C.C.I.R. systems I (United Kingdom)
Channels	E21 to E 69
Intermediate frequencies	
picture	39,5 MHz
sound	33,5 MHz

APPLICATION

Tuners U743 and U744 are intended for use in u.h.f. single standard receivers and to drive an i.f. surface acoustic wave (SAW) filter. For this, the tuners have a post-amplifier to compensate for the losses of the SAW filter.

The U743 is identical to the U744 but without frequency divider, necessary to drive digital tuning systems.

The pinning arrangements of the tuners are compatible with the tuners UV615, UV616, UV617, UV618, and the tuner part of the FE617Q(M) and FE618Q(M)/256, see page 9.

SURVEY OF TYPES

tuner type	aerial input connector	frequency divider (IC)	catalogue number
U743	phono	—	3122 237 00270
U743/IEC	IEC (14,5 mm)	—	3122 237 00280
U743/IEC.L	IEC (32,2 mm)	—	3122 237 00290
U744/256	phono	1 : 256	3122 237 00300
U744/256/IEC	IEC (14,5 mm)	1 : 256	3122 237 00310
U744/256/IEC.L	IEC (32,2 mm)	1 : 256	3122 237 00320

DESCRIPTION

The tuners are u.h.f. tuners with electronic tuning covering the u.h.f. band from 470 to 860 MHz (channels E21 to E69).

Mechanically the tuners are built on a printed-wiring board and enclosed in a metal housing, comprising a rectangular frame and front and rear covers (see Fig. 2). The aerial connection (phono or IEC) is on one of the frame sides, the supply voltage and i.f. connections are on the bottom side and the i.f. injection point is accessible through a hole in the cover as shown in Fig. 2.

Electrically the tuners consist of an input circuit with a high-pass characteristic and a MOS-FET tetrode BF990. The tetrode acts as an r.f. amplifier and as an a.g.c. device controlled by an a.g.c. voltage, fed to gate 2. The drain of the MOS-FET is connected to a double tuned circuit which transfers the signal to the mixer transistor 2SC3545. The r.f. selectivity of this circuit at the image frequency has been improved by special means. The mixer transistor is driven by an oscillator transistor BF569. The i.f. signal from the mixer is connected to a tuned i.f. filter and amplified by a BF370 post-amplifier, suitable to drive a surface acoustic wave filter (asymmetric), and to compensate for the SAW losses.

The combination of the r.f. MOS-FET, the 2 GHz mixer transistor and the i.f. post-amplifier ensures good noise figures and signal handling properties.

→ Three capacitance diodes BB405 tune the r.f. band-pass filter and oscillator circuit.

The electrical circuit of type U744 is extended with a frequency divider (division ratio of 256), the input of which is connected to the oscillator. The symmetrical outputs are connected to terminals 13 and 14.

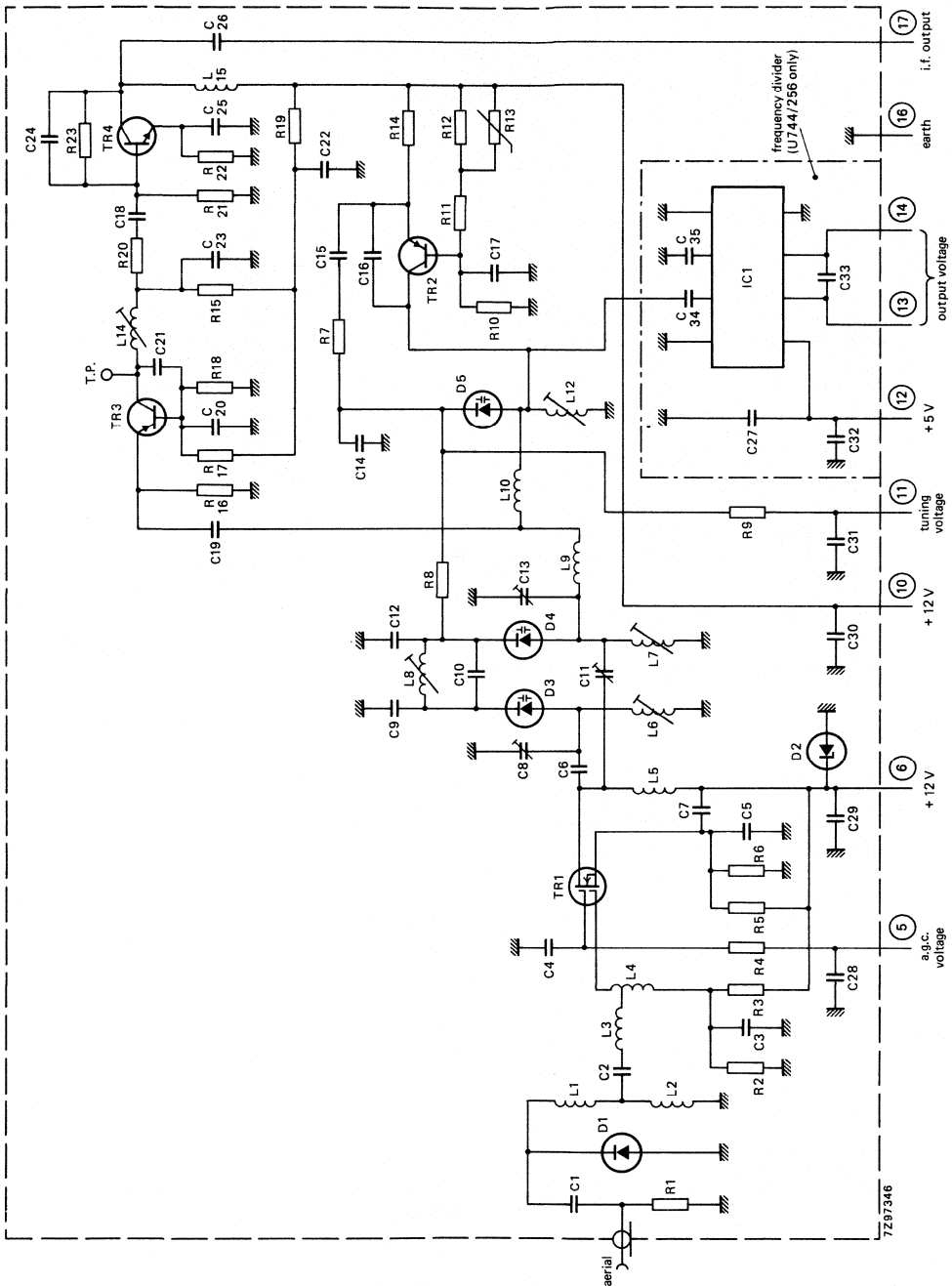

Fig. 1 For connections see also next page. T.P. = test point (i.f. injection).

MECHANICAL DATA

Dimensions in mm

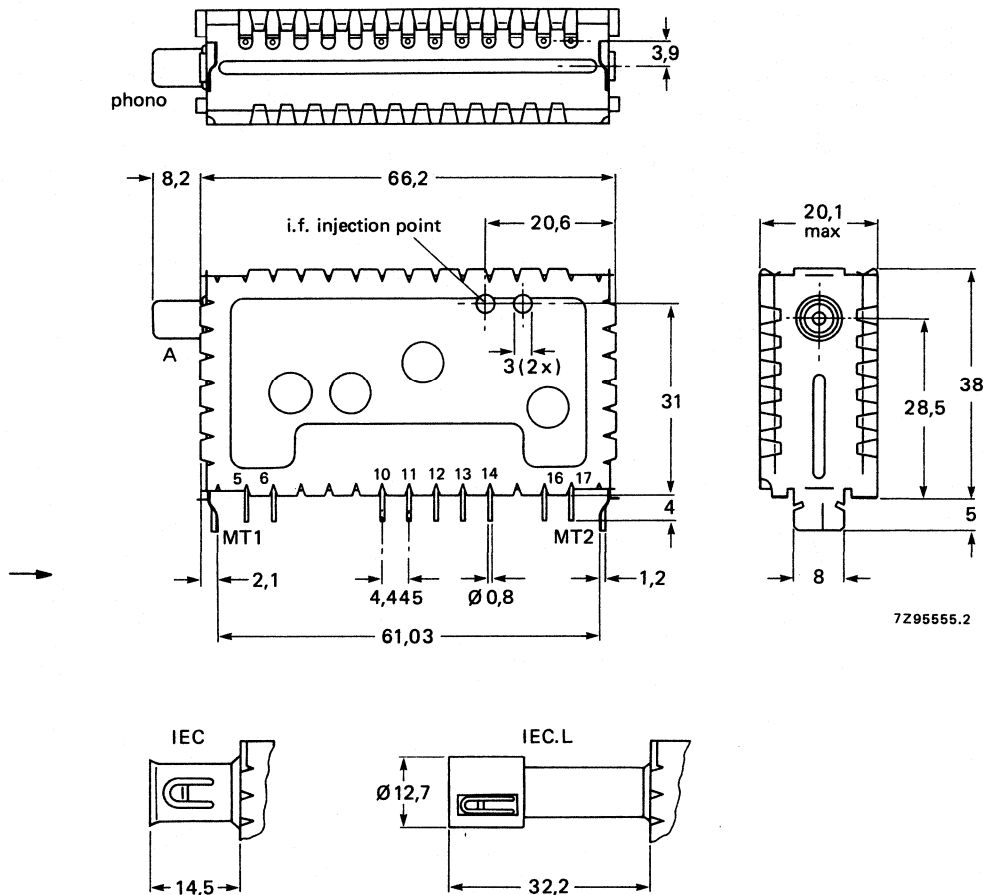

Fig. 2.

Terminal

- A = aerial input (phono/IEC female 75 Ω)
- 5 = a.g.c. voltage, + 9,2 to 0,85 V
- 6 = supply voltage, prestage, + 12 V
- 10 = supply voltage, oscillator, mixer, i.f., + 12 V
- 11 = tuning voltage, + 1 to + 28 V
- 12 = supply voltage frequency divider, + 5 V
- 13, 14 = balanced frequency divider output } U744 only
- 16 = earth
- 17 = i.f. output

Mass approx. 45 g

Mounting

The tuner may be mounted by soldering it on to a printed-wiring board (using the piercing diagram shown in Fig. 3) without clearance between tuner supports and board. It may be mounted anywhere in the receiver and there are no restrictions on orientation.

The solderability of the terminals and mounting tabs is according to IEC 68-2, test Ta ($230 \pm 10 \text{ }^\circ\text{C}$, $2 \pm 0,5 \text{ s}$). The resistance to soldering heat is according to IEC 68-2, test Tb ($260 \pm 5 \text{ }^\circ\text{C}$, $10 \pm 1 \text{ s}$).

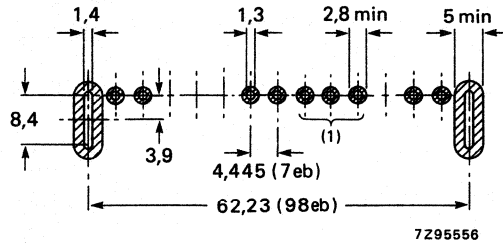

(1) Only for U744

1 eb = 0,025 inch

Fig. 3 Piercing diagram viewed from solder side of board.
Unless otherwise stated the tolerance is $\pm 0,05 \text{ mm}$.

In order to prevent any stress to the printed-wiring board, the tuner should be supported at its aerial connector.

ELECTRICAL DATA

Unless otherwise specified all electrical values apply at an ambient temperature of 25 ± 5 °C, a relative humidity of $60 \pm 15\%$, a supply voltage of $12 \pm 0,3$ V, an a.g.c. voltage of $9,2 \pm 0,2$ V, and a divider supply voltage of $5 \pm 0,2$ V.

Within the given tolerance range of supply voltage and a.g.c. voltage only insignificant deviations from the specified values can be expected. Under the extreme conditions of temperature and humidity as given below, the tuner will function normally, but some specified limits may be exceeded.

General

Semiconductors

r.f. amplifier	BF990
mixer transistor	2SC3545
oscillator	BF569
tuning diodes	3 x BB405
→ i.f. post-amplifier	BF370
surge protection diode	BAV10
surge protection diode	BZX79
Frequency divider	SP4653
Ambient temperature range	
operating	-10 to + 60 °C
storage	-25 to + 85 °C
Relative humidity	max. 100%

Voltages and currents

Supply voltage $+ 12 \text{ V} \pm 10\%$ (+ 10%, -15%)

Note: Supply voltages of $+ 12 \text{ V} - 15\%$ are admissible if a deterioration of gain, noise figure, signal handling, oscillator shift and drift is accepted. In this case the min. a.g.c. voltage has to be decreased to 0,8 V to cover the specified a.g.c. range.

Ripple susceptibility

Defined as the peak-to-peak value of a sine wave signal (20 Hz – 500 kHz) on the supply voltages causing an amplitude modulation with a modulation depth of 0,28% on the picture carrier after passing the Nyquist curve of the i.f. filter of a tv receiver.

ripple susceptibility	min. 3 mV peak-to-peak
Current drawn from + 12 V supply	
r.f. amplifier, at nominal gain	max. 21 mA
r.f. amplifier, at 30 dB gain reduction	typ. 11 mA
oscillator/i.f. amplifier	max. 36 mA
A.G.C. voltage (Fig. 4)	
voltage at nominal gain	$+ 9,2 \pm 0,5 \text{ V}$
voltage at 30 dB gain reduction	min. + 1 V

Note: A.G.C. voltages between 0 and $+ 10,5 \text{ V}$ may be applied without risk of damage.

A.G.C. current

during gain control (0 to 30 dB)	max. + 15 μA
at nominal gain	typ. + 11 μA

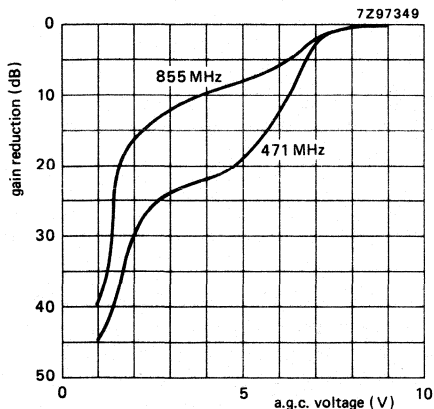

Fig. 4.

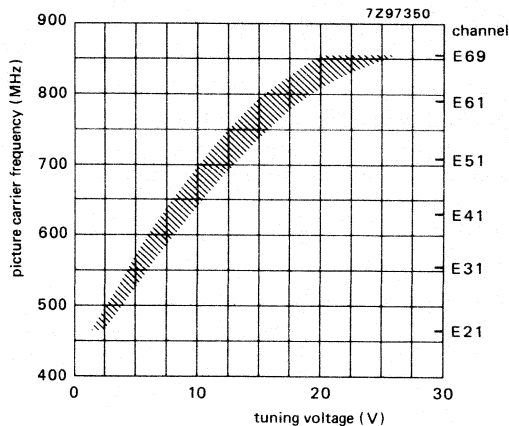

Fig. 5.

Tuning voltage range (Fig. 5)

Current drawn from + 28 V tuning voltage supply

at 25 °C

at 60 °C

at 25 °C (relative humidity 95%)

Slope of tuning characteristic

Frequencies

Frequency range

Intermediate frequencies

picture

sound

+ 1 to + 28 V

max. 0,15 μ A

max. 0,6 μ A

max. 0,6 μ A

min. 4 MHz/V

channel E21 (picture carrier 471,25 MHz)
to channel E69 (picture carrier 855,25 MHz).
Margin at the extreme channels: min. 3 MHz.

39,5 MHz

33,5 MHz

The oscillator frequency is higher than the
aerial signal frequency.

Wanted signal characteristics

Input impedance asymmetrical	75 Ω
V.S.W.R. and reflection coefficient at picture carrier frequency, at nominal gain and at 30 dB gain reduction v.s.w.r. reflection coefficient	typ. 4 typ. 60%
R.F. bandwidth	typ. 20 MHz
Overall curves, tilt R.F. in -I.F. out	on any channel the amplitude difference between the top of the overall curve and the picture carrier, the sound carrier, or any frequency between them will not exceed 3 dB at nominal gain, and 4 dB in the a.g.c. range between nominal gain and 20 dB gain reduction.
A.G.C. range	min. 30 dB
Voltage gain (i.f. load = 1200 Ω // 15 pF, see Fig. 7)	min. 40 dB
→ channel E21	typ. 40 dB
channel E40	typ. 41 dB
channel E69	typ. 42 dB
Gain difference between any two channels	typ. 4 dB
Noise figure	max. 10 dB
channel E21	typ. 6,0 dB
channel E40	typ. 6,5 dB
channel E69	typ. 7,5 dB
Overloading	
Input signal producing 1 dB gain compression at nominal gain	typ. 85 dB (μ V) into 75 Ω
Input signal producing either a detuning of the oscillator of + 300 kHz or -1000 kHz or stopping of the oscillations at nominal gain	typ. 100 dB (μ V) into 75 Ω
1,6 MHz moire rejection (for i.f. 39,5/33,5 MHz)	
Wanted signal level of a tv signal (picture to sound ratio of 7 dB and picture to chroma ratio of 16 dB), which produces an unwanted i.f. component (37,8 MHz) 52 dB below the i.f. picture carrier, when the tuner is 30 dB gain controlled.	
tv signal (picture carrier)	typ. 100 dB (μ V) into 75 Ω

Unwanted signal characteristics

Image rejection (measured at picture carrier frequency)

at nominal gain, channels E21 to E60	min.	53 dB; typ. 60 dB	
at 20 dB gain reduction, channels E21 to E60	typ.	50 dB	←

I.F. rejection (measured at picture carrier and colour sub-carrier frequency)

min. 80 dB

1st repeat spot rejection (for i.f. 39,5/33,5 MHz)

Defined as the input level of the picture carrier of channel N + 2, the sound carrier of which produces an i.f. signal (35,0 MHz), which is 52 dB below the picture carrier of the wanted signal N (picture to sound ratio 7 dB; wanted signal 60 dB (μV), tuner operating at nominal gain.

interfering signal typ. 80 dB (μV) into 75 Ω

N \pm 4 rejection

Interference signal for an interference ratio of 53 dB referred to wanted picture carrier (picture to sound carrier ratio of 7 dB; wanted signal 60 dB (μV); tuner operating at nominal gain)

N + 4 rejection typ. 80 dB (μV) into 75 Ω

N - 4 rejection typ. 78 dB (μV) into 75 Ω

Cross modulation

Input signal producing 1% cross modulation, i.e. 1% of the modulation depth of the interfering signal is transferred to the wanted signal.

In channel cross modulation (wanted signal: picture carrier frequency; interfering signal: sound carrier frequency)

at nominal gain (wanted input level 60 dB (μV)) typ. 80 dB (μV) into 75 Ω

at 26 dB gain reduction (wanted input level 86 dB (μV)) typ. 94 dB (μV) into 75 Ω

In band cross modulation (wanted signal: picture carrier of channel N; interfering signal: picture carrier of channel N \pm 5).

at nominal gain (wanted input level 60 dB (μV)) typ. 92 dB (μV) into 75 Ω

at 26 dB gain reduction (wanted input level 86 dB (μV)) typ. 95 dB (μV) into 75 Ω

Out of band modulation, at nominal gain

typ. 100 dB (μV) into 75 Ω ←

Unwanted signal handling capability

The tuner operates together with a standard tv receiver with normal A.G.C. for tuner and i.f. amplifier. Unwanted tv signal 3 channels higher or lower than wanted. Unwanted signal level adjusted for just not visible interference.

Unwanted picture carrier signal typ. 96 dB (μV)

Oscillator characteristics

Pulling

Input signal of tuned frequency producing a shift of the oscillator frequency of 10 kHz, at nominal gain typ. 85 dB (μV) into 75 Ω

Shift of oscillator frequency
at a change of the supply voltage of 5% max. 500 kHz

Drift of oscillator frequency
during warm-up time (after the tuner has been completely out of operation for 15 min, measured between 5 s and 15 min after switching on) max. 250 kHz

at a change of the ambient temperature
from + 25 to + 50 $^{\circ}\text{C}$ and + 25 $^{\circ}\text{C}$ to 0 $^{\circ}\text{C}$ (measured after 3 cycles from + 25 to + 55 $^{\circ}\text{C}$)
channels E21 to E69 max. 1000 kHz

at a change of humidity from 60% \pm 15% to 93% \pm 2% measured at $T_{\text{amb}} = 25^{\circ}\text{C} \pm 5^{\circ}\text{C}$ max. 1500 kHz

I.F. characteristics

Bandwidth of i.f. output circuit typ. 9 MHz

Note: I.F. output of the tuner terminated with the circuit shown in Fig. 7, tuning voltage 10 V.

I.F. output impedance approx. 100 Ω

Frequency divider characteristics

Values valid in the tuning voltage range 0,5 to 30 V

Supply voltage 5 V \pm 10%

Supply current max. 35 mA, typ. 25 mA

Output voltages (probe 10 M Ω //11 pF)
at pin 7 min. 0,5 V peak-to-peak

at pin 8 min. 0,5 V peak-to-peak

Output unbalance max. 0,1 V

Signal to interference ratio at an aerial input level of 100 μV , measured at i.f. output min. 46 dB

Miscellaneous

Radio interference

Oscillator radiation and oscillator voltage
at the aerial terminal

Within the limits of C.I.S.P.R. 13 (1975)
+ amendment 1 (1983).
Use is made of the relaxed limit of 3 mV/m
(70 dB ($\mu\text{V/m}$)).

Immunity from radiated interference

Aerial terminal meets requirements of BS905, provided the aerial cable is connected in a professional manner.

Microphonics

There will be no microphonics, provided the tuner is installed in a professional manner.

Surge protection

Protection against voltages

max. 5 kV



Note: Ten discharges of a 470 pF capacitor into the aerial terminal.

E.S.D. protection

min. 2 kV

Note: acc. to MIL STD 003C

ADDITIONAL INFORMATION

I.F. injection

The tuner has an i.f. injection point at the collector of the mixer transistor (see Figs 1 and 2). The i.f. generator can be connected directly to this point (Fig. 6), via a 0,3 pF capacitor. The tuner needs normal supply voltages and a tuning voltage of 10 V.

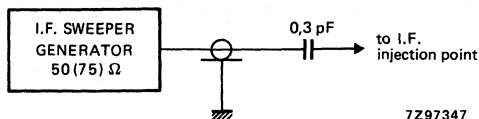

Fig. 6.

Voltage gain

Since the r.f. input and the i.f. output load impedances differ, the gain of the U743 U744 tuners are expressed in terms of voltage gain. It is defined as the ratio between the i.f. output voltage and the corresponding r.f. input voltage.

The i.f. output of the tuner is loaded with an impedance of 1200 Ω in parallel with a 15 pF capacitor representing a standard replacement of the input impedance of a SAW filter.

To be able to carry out tuner measurements with existing 75 Ω equipment a matching circuit is connected to the i.f. output of the tuner. The input gives the required load to the tuner output while the output represents a source impedance suitable to connect to standard 75 Ω equipment, see Fig. 7.

Total losses of the circuit are 26 dB.

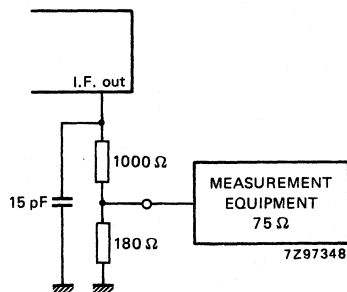

Fig. 7.

V.H.F./U.H.F. TELEVISION TUNERS

QUICK REFERENCE DATA

Systems	C.C.I.R. systems L and L'
Channels	
low v.h.f.	E2 to E4
high v.h.f.	C to Q
u.h.f.	L21 to L69
Intermediate frequencies	
picture	32,7 MHz
sound	39,2 MHz

APPLICATION

Designed to cover the v.h.f. and u.h.f. channels of C.C.I.R. systems L and L', with extended v.h.f. range including channels for French cable television (CCETT 12 MHz frequency plan).

The tuner USF10A is equipped with a frequency divider (1 : 256), which makes it suitable for digital tuning systems based on frequency synthesis; otherwise this tuner is equal to type USF10.

DESCRIPTION

The USF10 is a combined v.h.f./u.h.f. tuner with electronic tuning and band switching covering the low v.h.f. band including the European channel E4 (frequency range 48 to 68 MHz), the high v.h.f. band including the Moroccan channel M4 and the European channel E12 (frequency range 128 to 306 MHz) and the u.h.f. band (frequency range 470 to 861 MHz).

Mechanically, the tuner is built on a low-loss printed-wiring board, carrying all components, in a metal housing made of a rectangular frame and front and rear covers (see Fig. 1). The common aerial connection (v.h.f. and u.h.f.) with standard coaxial termination is on one of the frame sides, all other connections (supply voltages, a.g.c. voltage, tuning and switching voltages, i.f. output) are made via terminals in the underside. The mounting method is shown in Fig. 2.

Electrically, the tuner consists of v.h.f. and u.h.f. parts. The v.h.f. aerial signal is fed via switchable v.h.f. band wideband input filters to gate 1 of an input MOSFET tetrode (with internal gate protection against surge).

The drain load of the MOSFET tetrode is formed by a double tuned switchable bandpass filter, transferring the r.f. signal to the emitter of the mixer transistor. The oscillator signal is also fed to the emitter of the mixer transistor.

The collector circuit of the mixer transistor is a single tuned i.f. resonant circuit, at the low end of which the i.f. signal is coupled out of the tuner. A test point (terminal 4) is provided for i.f. injection to align the output circuit of the tuner together with the i.f. amplifier of the television receiver.

The input tuned circuit, the r.f. bandpass filter and oscillator circuit are tuned by 8 tuning diodes, band switching is achieved by 9 switching diodes.

The u.h.f. part of the tuner consists of a tuned input circuit connected to gate 1 of an input MOSFET tetrode (with internal gate protection against surge). The drain load of this MOSFET tetrode is formed by a double tuned circuit transferring the r.f. signal to the Schottky barrier mixer diode. The i.f. signal from the mixer diode is amplified by the v.h.f. mixer transistor, now operating as an i.f. amplifier.

The input tuned circuit, the r.f. bandpass filter and oscillator circuits are tuned by 4 tuning diodes.

In all bands the tuner is gain controlled via gate 2 of the input MOSFET tetrodes.

MECHANICAL DATA

Dimensions in mm

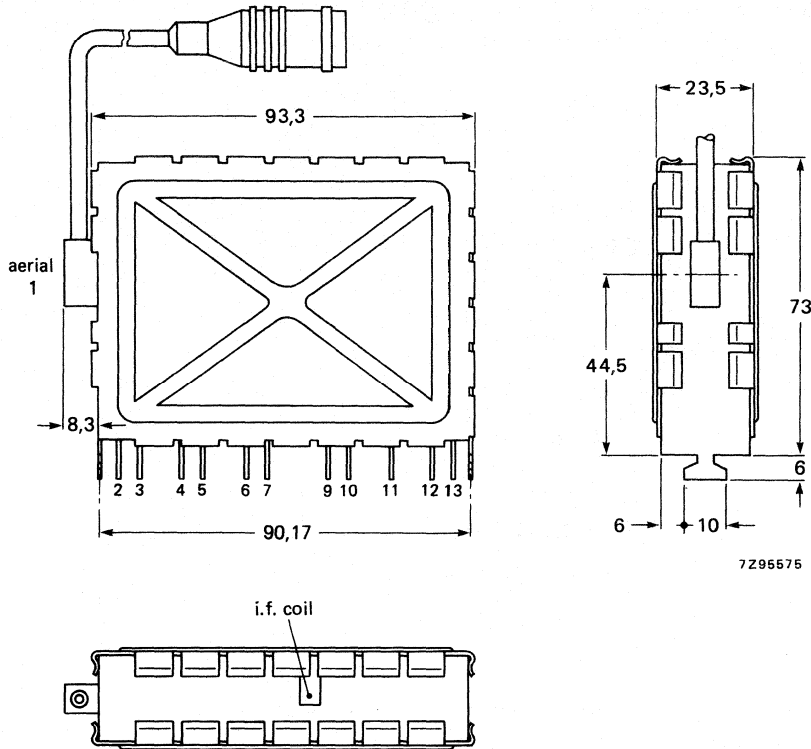

7295575

Fig. 1a.

Terminal

- 1 = aerial
 - 2 = supply voltage, low v.h.f., + 12 V
 - 3 = supply voltage, high v.h.f., + 12 V
 - 4 = supply voltage, u.h.f., + 12 V; i.f. injection
 - 5 = a.g.c. voltage, + 8,25 to + 0,85 V
 - 6 = supply voltage, v.h.f. and u.h.f., + 12 V
 - 7 = tuning voltage, + 0,5 to + 28 V
 - 9 = i.f. output
 - 10 = earth
 - 11/12 = balanced output voltage of frequency divider
 - 13 = supply voltage, frequency divider, 5 V ± 5%
- } USF10A
only

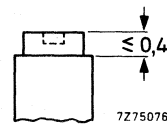

7275076

Fig. 1b I.F. output coil.
Torque for alignment: 2 to 15 mNm
Press-through force: ≥ 10 N.

Mass approx. 130 g

Mounting

The tuner may be mounted by soldering it onto a printed-wiring board, using the piercing diagram shown in Fig. 2. (The tuner may also be mounted by means of a socket. Information will be supplied upon request.) The tuner may be mounted anywhere in the receiver and there are no restrictions on orientation.

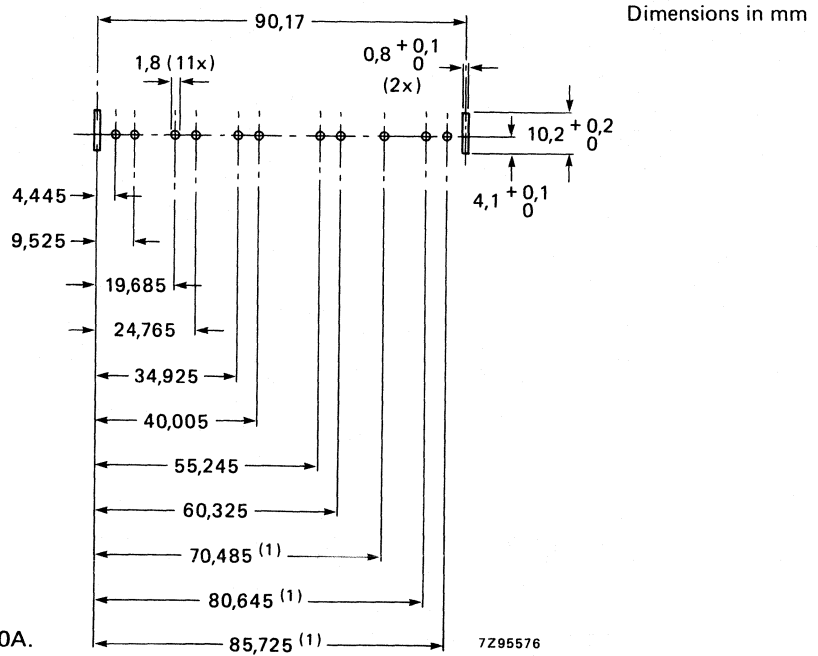

Fig. 2 Piercing diagram for tuner USF10A viewed from solder side of board. Unless otherwise stated the tolerance is $\pm 0,05$ mm.

ELECTRICAL DATA

Unless otherwise specified all electrical values apply at an ambient temperature of 25 ± 5 °C, a relative humidity of $60 \pm 15\%$, a supply voltage of $12 \pm 0,3$ V and an a.g.c. voltage of $8,25 \pm 0,2$ V.

Voltages and currents

Supply voltage	+ 12 V \pm 1 V
Current drawn from + 12 V supply	
low v.h.f. band	max. 45 mA; typ. 40 mA
high v.h.f. band	max. 80 mA; typ. 76 mA
u.h.f. bands	max. 50 mA; typ. 45 mA

Bandswitching

For operation in all bands the supply voltage is permanently connected to terminal 6. Additionally the supply voltage is connected to:

- terminal 2 and -12 V to terminal 3 for operation in the low v.h.f. band
- terminal 3 and -12 V to terminal 2 for operation in the high v.h.f. band
- terminal 4 and -12 V to terminals 2 and 3 for operation in the u.h.f. bands.

A.G.C. voltage (Figs 3, 4 and 5)

voltage range	+ 8,25 to + 0,85 V
voltage at nominal gain	+ 8,25 \pm 0,5 V
voltage at 40 dB gain reduction	
low v.h.f. band	typ. 2 V
high v.h.f. band	typ. 1,2 V

Note: A.G.C. voltages between 0 and + 10,5 V may be applied without risk or damage.

A.G.C. current	max. 0,3 μ A
Tuning voltage range	+ 0,5 to + 28 V

Current drawn from 28 V tuning voltage supply

at $T_{amb} = 25$ °C	max. 0,8 μ A
at $T_{amb} = 55$ °C	max. 3 μ A

Slope of tuning characteristics (typical values)

low v.h.f. band, channel 2	2 MHz/V
channel 4	1,5 MHz/V
high v.h.f. band, channel C	12 MHz/V
channel Q	2 MHz/V
u.h.f. bands, channel L21	30 MHz/V
channel L69	6 MHz/V

Frequencies

Frequency ranges	
low v.h.f. band	channel E2 (picture carrier 48,25 MHz) Margin: min. tuning voltage 2 V
	channel E4 (picture carrier 62,25 MHz) Margin: max. tuning voltage 22 V

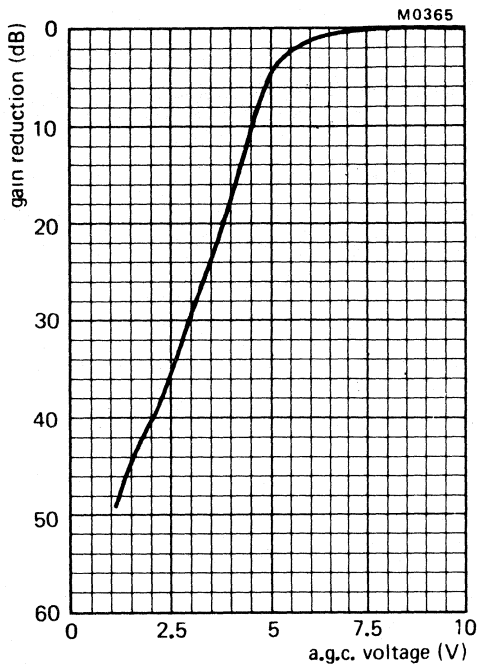

Fig. 3 Typical a.g.c. characteristic, low v.h.f. band.

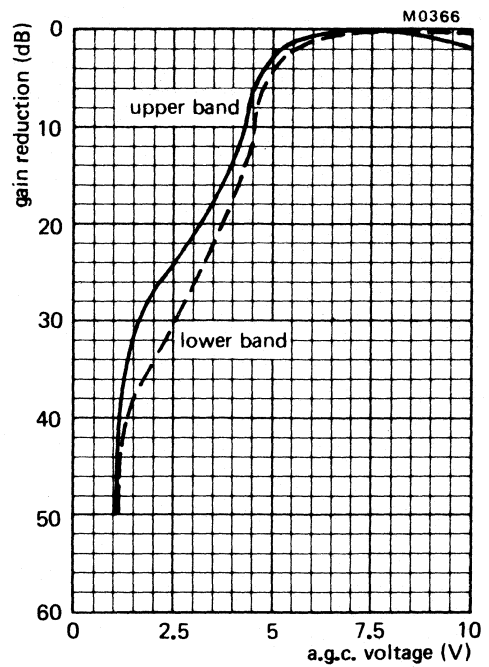

Fig. 4 Typical a.g.c. characteristic, high v.h.f. band.

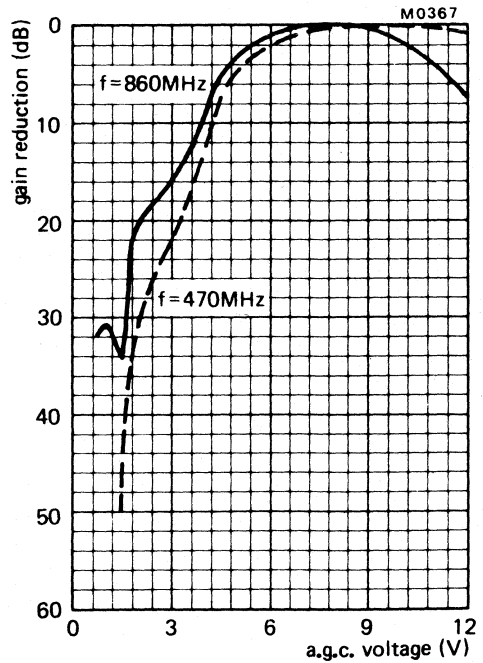

Fig. 5 Typical a.g.c. characteristic, u.h.f. bands.

Frequencies (continued)

Frequency range

high v.h.f. band (cable)

channel C (picture carrier 128,75 MHz)
Margin: min. 0,75 MHzchannel Q (picture carrier 296,75 MHz)
Margin: min. 1,8 MHz

u.h.f. bands

channel L21 (picture carrier 471,25 MHz) to
channel L69 (picture carrier 855,25 MHz)
Margin at the extreme channels: 2 MHz

Intermediate frequencies

picture

32,7 MHz

sound

39,2 MHz

Wanted signal characteristics

Input impedance

75 Ω

V.S.W.R. and reflection coefficient

(values between picture and sound carrier,
as well as values at picture carrier)

at nominal gain

during gain control

v.s.w.r.

v.h.f. bands

max. 4,5

max. 4,5

u.h.f. bands

max. 5

max. 6

reflection coefficient

v.h.f. bands

max. 63%

max. 63%

u.h.f. bands

max. 56%

max. 56%

R.F. curves, bandwidth

low v.h.f. band

typ. 16 MHz

high v.h.f. band

typ. 16 MHz

u.h.f. bands

typ. 30 MHz

R.F. curves, tilt

on any channel the amplitude difference between
the top of the r.f. resonant curve and the picture
frequency, the sound frequency, or any frequency
between them will not exceed:

nominal gain

in the first 20 dB
of the a.g.c. range

low v.h.f. band

3 dB

4 dB

high v.h.f. band

3 dB

4,5 dB

u.h.f. bands

3 dB

4 dB

A.G.C. range

v.h.f. bands

min. 40 dB

u.h.f. bands

min. 30 dB

Wanted signal characteristics (continued)

Power gain (see also measuring method for power gain Figs 7 and 8)

v.h.f. bands	min. 19 dB
u.h.f. bands	min. 19 dB

Maximum gain difference

between any two v.h.f. channels	typ. 6 dB
between any two u.h.f. channels	typ. 6 dB

Noise figure

v.h.f. bands	max. 9 dB, channel C: max. 10 dB
low v.h.f. band	typ. 6 dB
high v.h.f. band	typ. 6 dB, channel C: typ. 7 dB
u.h.f. bands	max. 10 dB
channel L21	typ. 5,5 dB
channel L40	typ. 6,5 dB
channel L69	typ. 7,5 dB

Unwanted signal characteristics

Image rejection (measured at picture carrier frequency)

low v.h.f. band	min. 60 dB
high v.h.f. band	min. 55 dB, typ. 60 dB
u.h.f. bands	min. 40 dB, typ. 50 dB

I.F. rejection (measured at picture carrier frequency)

low v.h.f. band	
channel 2	min. 20 dB
channel 4	min. 30 dB
high v.h.f. band	min. 60 dB
u.h.f. bands	min. 60 dB

Cross modulation

Input signal producing 1% cross modulation, i.e. 1% of the modulation depth of the interfering signal is transferred to the wanted signal.

In channel cross modulation (wanted signal: picture carrier frequency; interfering signal: sound carrier frequency)

low v.h.f. band	
at nominal gain(wanted input level 60 dB (μ V))	typ. 67 dB (μ V) into 75 Ω
at 20 dB gain reduction	typ. 85 dB (μ V) into 75 Ω
high v.h.f. band	
at nominal gain	typ. 70 dB (μ V) into 75 Ω
at 20 dB gain reduction	typ. 90 dB (μ V) into 75 Ω
u.h.f. bands	
at nominal gain	typ. 70 dB (μ V) into 75 Ω
at 20 dB gain reduction	typ. 90 dB (μ V) into 75 Ω

In band cross modulation (wanted signal: picture carrier of channel N; interfering signal: picture carrier of channel $N \pm 3$ for all bands).

high v.h.f. band at nominal gain (wanted input level 60 dB (μ V))	typ. 95 dB (μ V) into 75 Ω
u.h.f. bands at nominal gain	typ. 85 dB (μ V) into 75 Ω

Oscillator characteristics

Shift of oscillator frequency at a change of the supply voltage of 5%

v.h.f. bands	max. 500 kHz
u.h.f. bands	max. 1000 kHz
channel L21	typ. 600 kHz
channel L40	typ. 100 kHz
channel L69	typ. 200 kHz

Drift of oscillator frequency at a change of the ambient temperature from + 25 to + 40 °C (measured after 3 cycles from + 25 to + 55 °C)

v.h.f. bands	max. 350 kHz
u.h.f. bands	max. 600 kHz

I.F. circuit characteristics

Minimum tuning range of i.f. output coil 32 to 40 MHz

Miscellaneous

Oscillator voltage at the aerial terminal

Fundamental and harmonic frequencies up to 1000 MHz	
v.h.f. bands	max. 50 dB (μ V) into 75 Ω
u.h.f. bands	max. 66 dB (μ V) into 75 Ω

ADDITIONAL INFORMATION

I.F. injection

Terminal 4 (supply voltage u.h.f.) can be used as i.f. injection point, provided the u.h.f. supply voltage is applied to terminal 4 via a resistor of $56\ \Omega$ (see Fig. 6). The u.h.f. band should be switched on; a tuning voltage of $-12\ \text{V}$ is applied to terminal 7.

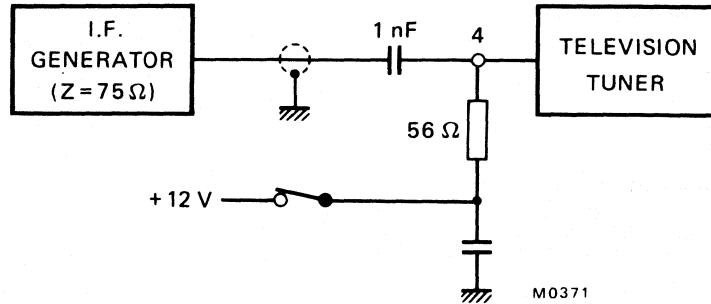

Fig. 6.

Connection of the i.f. amplifier

No special precautions are required to load and to match the i.f. output of the tuner.

Measuring method of power gain

The i.f. output of the tuner should be terminated with the circuit given in Fig. 7.

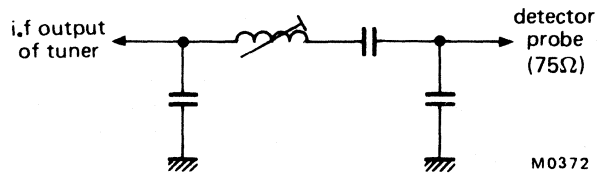

Fig. 7.

This circuit roughly matches the i.f. output impedance to $75\ \Omega$ at the resonant frequency of the i.f. output circuit (Fig. 8).

Because the input and output impedances of the tuner are now $75\ \Omega$, the power gain can be measured in the conventional manner by inserting tuner and the circuit between a $75\ \Omega$ source and a $75\ \Omega$ detector.

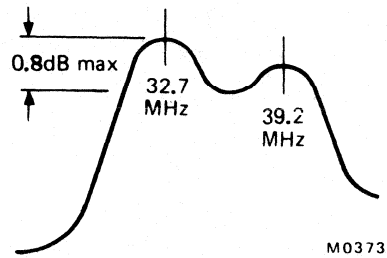

Fig. 8.

Alignment of the i.f. output coil

The i.f. output coil should be adjusted with a brass tool with a blade as shown in Fig. 9. A suitable tool is available under catalogue number 7122 005 47680.

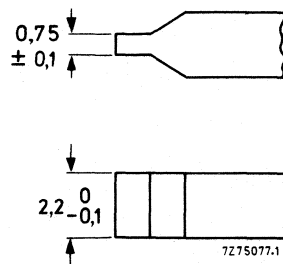

Fig. 9.

V.H.F./U.H.F. TELEVISION TUNERS

QUICK REFERENCE DATA

Systems	C.C.I.R. systems B and G
Channels	
v.h.f. I	NZ1 to C
v.h.f. III	M4 to E12
u.h.f.	E21 to E69
Intermediate frequencies	
picture	38,9 MHz
sound	33,4 MHz

APPLICATION

Designed to cover the v.h.f. and u.h.f. channels of C.C.I.R. systems B and G, with extended v.h.f. frequency ranges.

The tuners of the UV412 series are equipped with a frequency divider, which makes them suitable for digital tuning systems based on frequency synthesis; for the remainder they are equal to type UV411.

Available versions

	aerial input connector	frequency divider (IC)	division ratio	catalogue number
UV411	phono	—	—	3122 127 24360
UV411/IEC	IEC	—	—	3122 127 08870
UV412	phono	14-pin	256	3122 127 42010
UV412/256	phono	8-pin	256	3122 127 09060
UV412/256/IEC	IEC	8-pin	256	3122 127 08880
UV412/64	phono	8-pin	64	3122 127 08900
UV412/64/IEC	IEC	8-pin	64	3122 127 08890

UV411 SERIES UV412 SERIES

DESCRIPTION

The UV411 and UV412 are combined v.h.f./u.h.f. tuners with electronic tuning and band switching, covering the v.h.f. band I including the New Zealand channel 1, and the Italian channel C (frequency range 44 to 92 MHz), the v.h.f. band III including the Morocco channel M4 (frequency range 162 to 230 MHz), and the u.h.f. band (frequency range 470 to 861 MHz).

Mechanically, the tuners are built on a low-loss printed-wiring board, carrying all components, in a metal housing made of a rectangular frame and front and rear covers (see Fig. 2). The common phono or IEC aerial connector (v.h.f. and u.h.f.) is on one of the frame sides, all other connections (supply voltages, a.g.c. voltage, tuning and switching voltages, i.f. output) are made via terminals in the underside. The mounting method is shown in Fig. 3.

Electrically, the tuners consist of v.h.f. and u.h.f. parts. The v.h.f. aerial signal is fed via switchable v.h.f. band I/III wide band input filters to gate 1 of an input MOSFET tetrode (with internal gate protection against surge).

The input filters are provided with an i.f. and f.m. suppression circuit. The drain load of the MOSFET tetrode is formed by a double tuned switchable bandpass filter, transferring the r.f. signal to the emitter of the mixer transistor. The oscillator signal is also fed to the emitter of the mixer transistor.

The collector circuit of the mixer transistor is a single tuned i.f. resonant circuit, at the low end of which the i.f. signal is coupled out of the tuner. A test point (terminal 4) is provided for i.f. injection to align the i.f. output circuit of the tuner together with the i.f. amplifier of the television receiver. An additional test point, which is accessible through a hole in the top of the tuner, is connected to the collector of the mixer transistor.

The r.f. band pass filter and oscillator circuits are tuned by 3 tuning diodes; band switching is achieved by 5 switching diodes.

The u.h.f. part of the tuner consists of a high-pass input circuit connected to gate 1 of an input MOSFET tetrode (with internal gate protection against surge). The drain load of this MOSFET tetrode is formed by a double tuned circuit transferring the r.f. signal to the Schottky barrier mixer diode. The i.f. signal from the mixer diode is amplified by the v.h.f. mixer transistor, now operating as an i.f. amplifier.

The r.f. band pass filter and oscillator circuits are tuned by 3 tuning diodes.

In all bands the tuner is gain controlled via gate 2 of the input MOSFET tetrode.

The electrical circuit of the UV412 series is extended with a frequency divider (division ratio of 64 or 256), which inputs are connected to the v.h.f. and u.h.f. oscillator. The complementary outputs are connected to terminals 12 and 13.

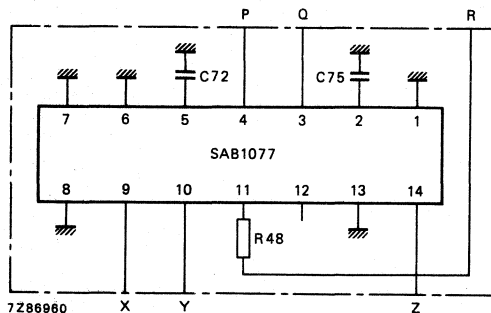

Fig. 1a.

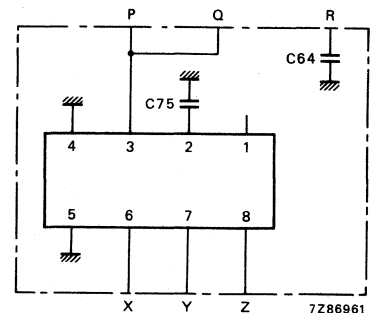

Fig. 1b.

See Fig. 1c.

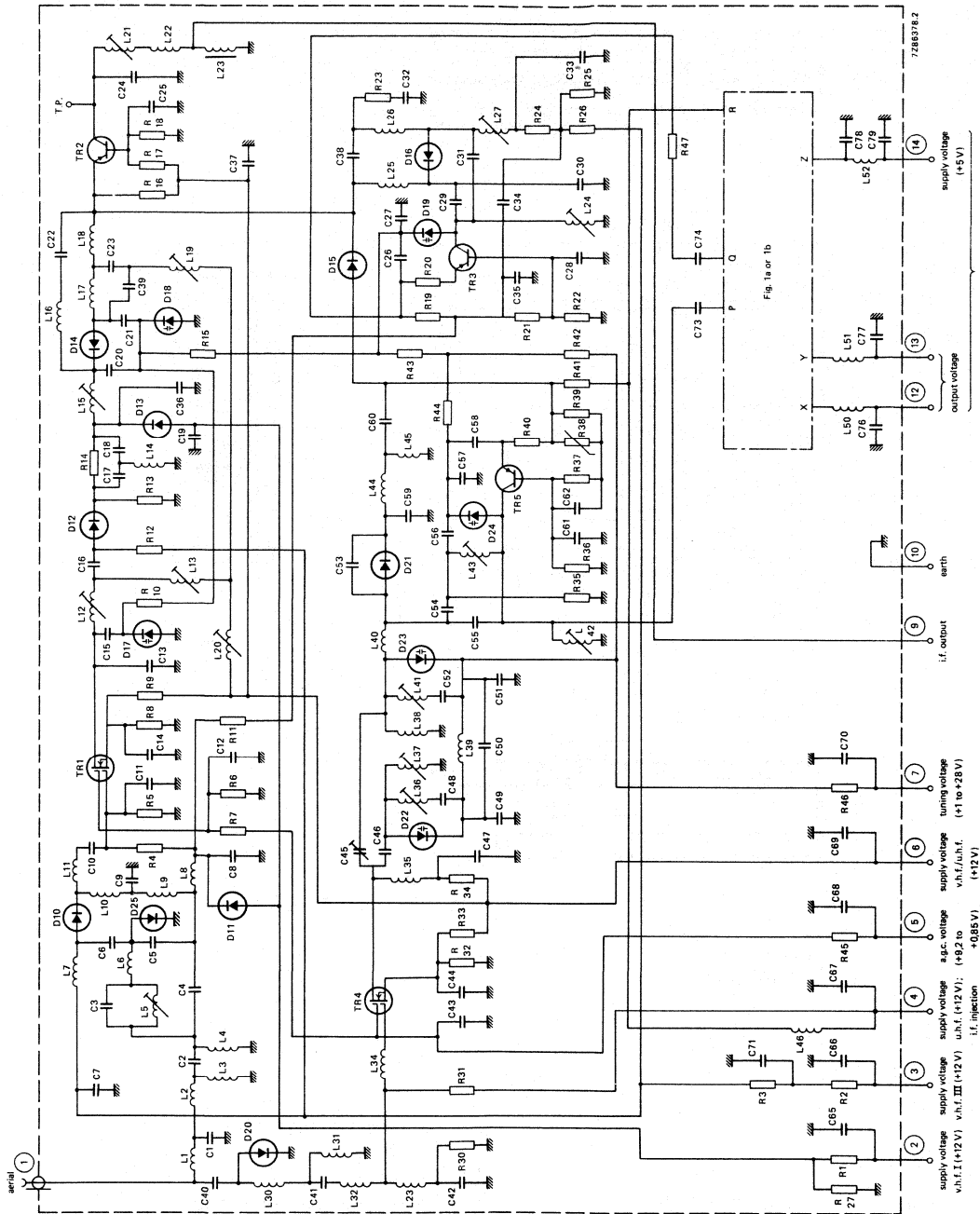

Fig. 1c.

* C64 only in versions with IC of Fig. 1b.

UV411 SERIES UV412 SERIES

MECHANICAL DATA

Dimensions in mm

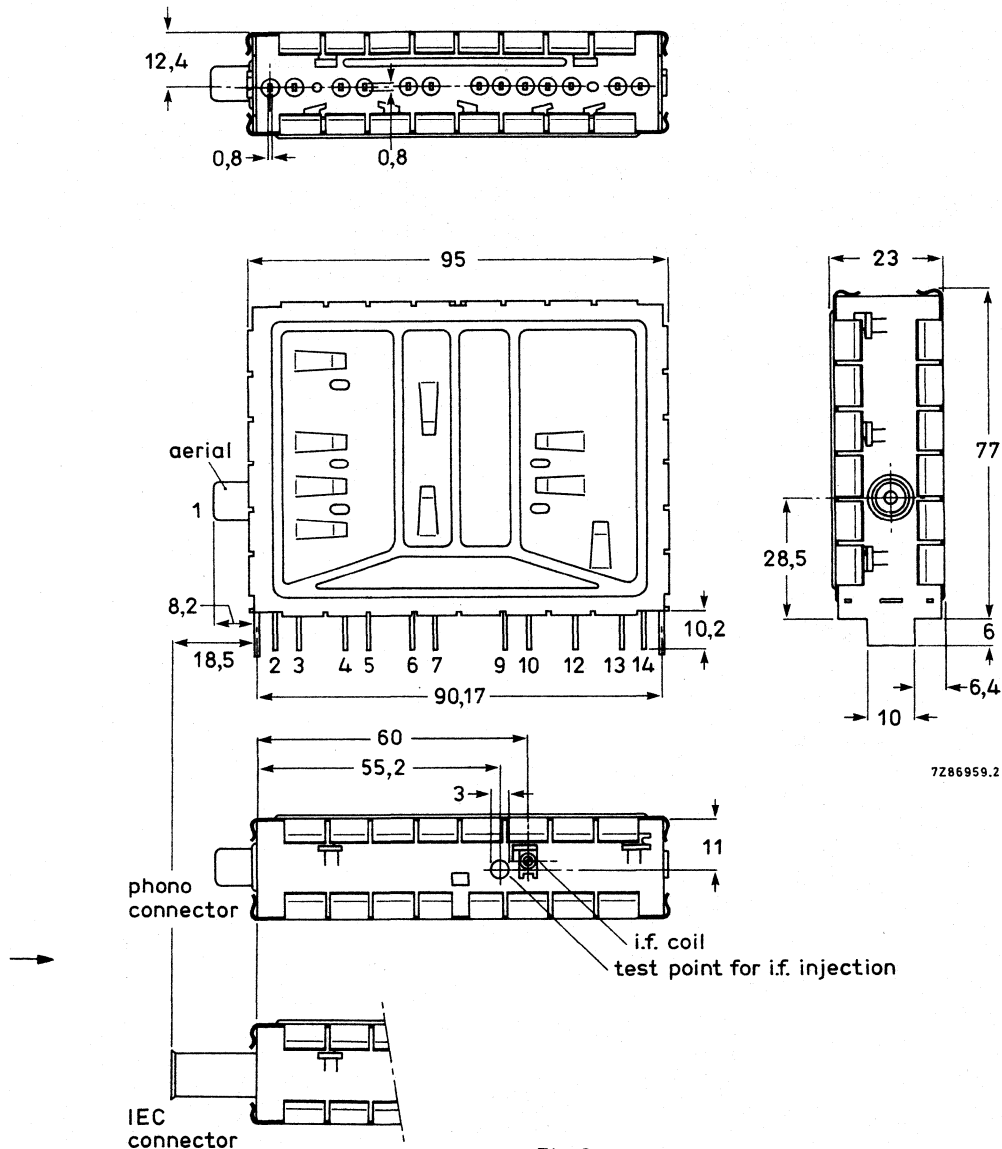
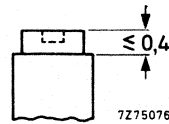

Fig. 2a.

Terminal

- | | | |
|--|--|------------------|
| 1 = aerial | 7 = tuning voltage, + 1 to + 28 V | |
| 2 = supply voltage, v.h.f. I, + 12 V | 9 = i.f. output | |
| 3 = supply voltage, v.h.f. III, + 12 V | 10 = earth | |
| 4 = supply voltage, u.h.f., + 12 V; i.f. injection | 12,13 = balanced output voltage of frequency divider | } only for UV412 |
| 5 = a.g.c. voltage, + 9,2 to + 0,85 V | 14 = supply voltage, frequency divider, + 5 V | |
| 6 = supply voltage, v.h.f. and u.h.f., + 12 V | | |

Fig. 2b I.F. output coil.
Torque for alignment: 2 to 15 mNm.
Press-through force: ≥ 10 N.



Mass approx. 127 g

Mounting

The tuner may be mounted by soldering it on to a printed-wiring board, using the piercing diagram shown in Fig. 3. (The tuner may also be mounted by means of a bracket. Information will be supplied upon request.) The tuner may be mounted anywhere in the receiver and there are no restrictions on orientation.

The solderability of the terminals and mounting tabs is according to IEC 68-2, test Ta (230 ± 10 °C, $2 \pm 0,5$ s). The resistance to soldering heat is according to IEC 68-2, test Tb (260 ± 5 °C, 10 ± 1 s).

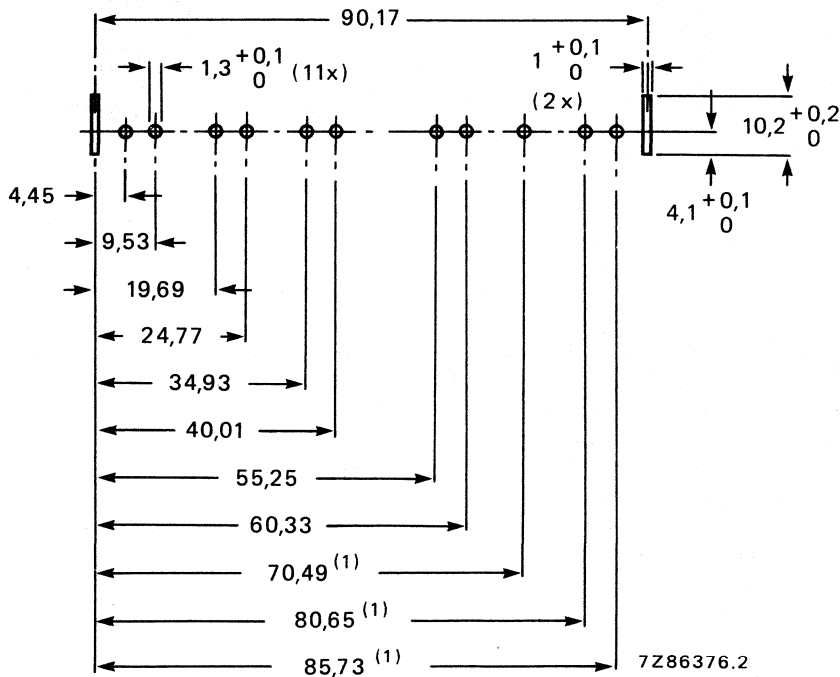

(1) Only for UV412.

Fig. 3 Piercing diagram viewed from solder side of board. Unless otherwise stated the tolerance is $\pm 0,05$ mm.

UV411 SERIES UV412 SERIES

ELECTRICAL DATA

Unless otherwise specified all electrical values apply at an ambient temperature of 25 ± 5 °C, a relative humidity of 60 ± 15 %, a supply voltage of $12 \pm 0,3$ V and an a.g.c. voltage of $9,2 \pm 0,2$ V.

General

Semiconductors, bands I and III

r.f. amplifier	BF982
mixer	BF324
oscillator	BF926
tuning diodes	3 x BB809
switching diodes	5 x BA482/483/484
d.c. blocking diodes	2 x BAW62

Semiconductors, bands IV and V

r.f. amplifier	BF980 (3SK87)
oscillator	BF970
mixer	1SS99
tuning diodes	3 x BB405B
surge protection diodes	2 x BAV10
frequency divider	SP4653 or SP4632

Ambient temperature range

operating	0 to + 55 °C
storage	-25 to + 70 °C

Relative humidity

max. 95%

Voltages and currents

Supply voltage

+ 12 V \pm 10%

Current drawn from + 12 V supply

bands I and III	max. 55 mA; typ. 44 mA
bands IV and V	max. 50 mA; typ. 40 mA

Bandswitching

For operation in all bands the supply voltage is permanently connected to terminal 6. Additionally the supply voltage is connected to:

- terminal 2 for operation in band I,
- terminal 3 for operation in band III,
- terminal 4 for operation in bands IV and V.

A.G.C. voltage (Figs 4, 5 and 6)

voltage range	+ 9,2 to + 0,85 V
voltage at nominal gain	+ 9,2 \pm 0,5 V
voltage at 40 dB gain reduction	
band I	typ. 3 V
band III	typ. 1,5 V
voltage at 30 dB gain reduction	typ. 2 V

Note: A.G.C. voltages between 0 and + 10,5 V may be applied without risk of damage.

A.G.C. current

max. 0,3 mA

Slope of a.g.c. characteristic, at the end of the specified a.g.c. range

bands I and III	typ. 25 dB/V
bands IV and V	typ. 50 dB/V

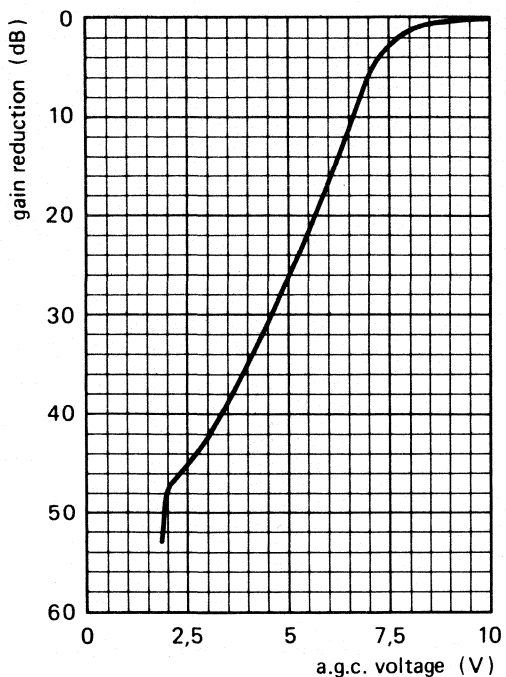

Fig. 4 Typical a.g.c. characteristic, band I.

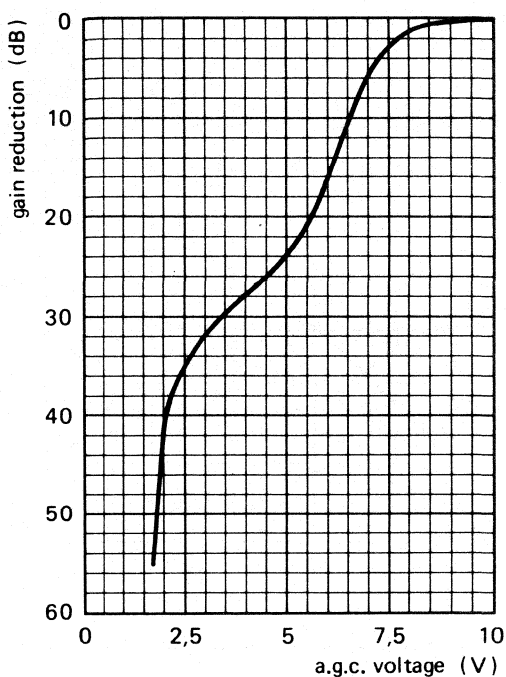

Fig. 5 Typical a.g.c. characteristic, band III.

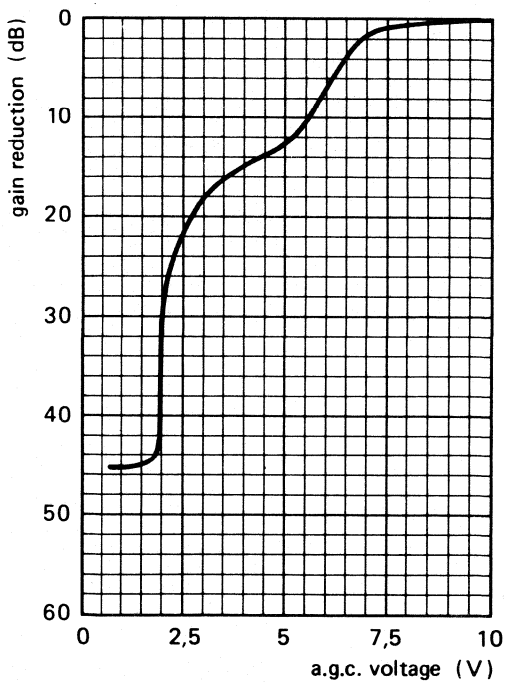

Fig. 6 Typical a.g.c. characteristic, bands IV and V.

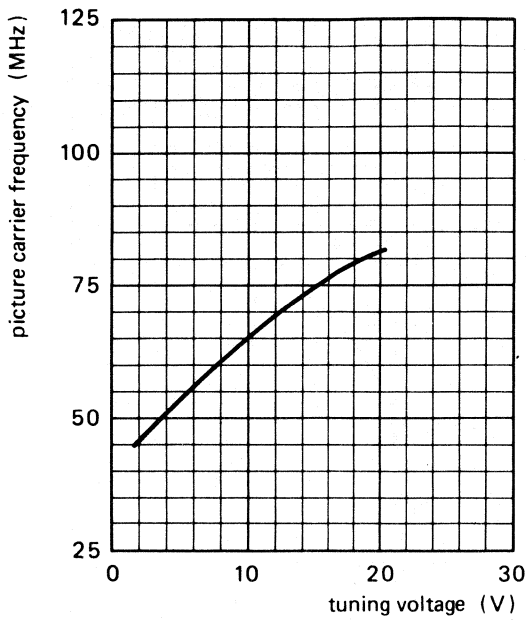

Fig. 7 Typical tuning characteristic, band I.

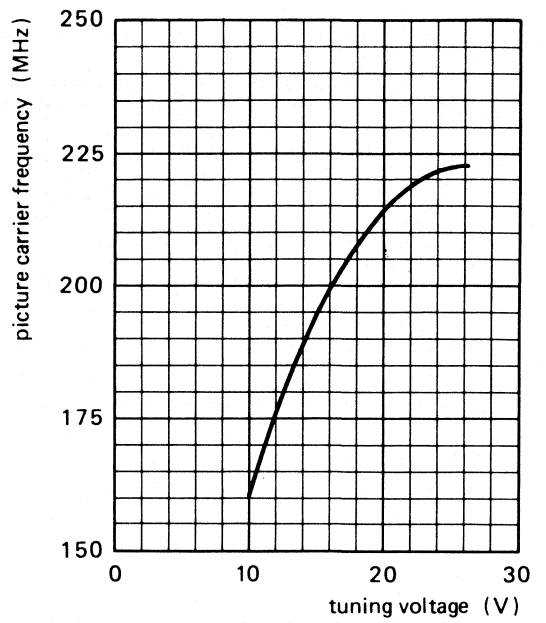

Fig. 8 Typical tuning characteristic, band III.

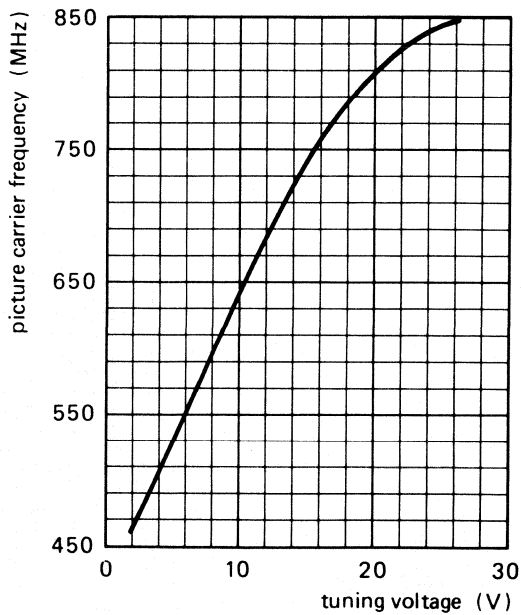

Fig. 9 Typical tuning characteristic, bands IV and V.

Tuning voltage range (Figs 7, 8 and 9)	+ 1 to + 28 V
Current drawn from 28 V tuning voltage supply	
at $T_{amb} = 25^{\circ}C$	max. 0,5 μA
at $T_{amb} = 55^{\circ}C$	max. 2 μA

Note: The source impedance of the tuning voltage offered to terminal 7 must be maximum 47 k Ω .

Slope of tuning characteristic		
band I, channel E2	3 MHz/V	} typical values
channel E4	2 MHz/V	
band III, channel E5	7 MHz/V	
channel E12	2 MHz/V	
bands IV and V, channel E21	22 MHz/V	
channel E69	5 MHz/V	

Frequencies

Frequency ranges	
band I	channel NZ1 (picture carrier 45,25 MHz) to channel C (picture carrier 82,25 MHz).*
	Margin at the extreme channels: min. 1,5 MHz.
band III	channel M4 (picture carrier 163,25 MHz) to channel E12 (picture carrier 224,25 MHz).
	Margin at the extreme channels: min. 2 MHz.
bands IV and V	channel E21 (picture carrier 471,25 MHz) to channel E69 (picture carrier 855,25 MHz).
	Margin at the extreme channels: min. 3 MHz.
Intermediate frequencies	
picture	38,9 MHz
sound	33,4 MHz
	The oscillator frequency is higher than the aerial signal frequency.

Wanted signal characteristics

Input impedance	75 Ω	
V.S.W.R. and reflection coefficient (values between picture and sound carrier, as well as values at picture carrier)		
v.s.w.r.	at nominal gain	during gain control
bands I and III	max. 4,5	max. 5,5
bands IV and V	max. 5	max. 7
reflection coefficient		
bands I and III	max. 64%	max. 69%
bands IV and V	max. 66%	max. 75%
R.F. curves, bandwidth		
band I	typ. 11 MHz	
band III	typ. 13 MHz	
bands IV and V	typ. 20 MHz	

* Channel R4 (picture carrier 85,25 MHz) is within the frequency range, but not specified.

UV411 SERIES UV412 SERIES

R.F. curves, tilt

on any channel the amplitude difference between the top of the r.f. resonant curve and the picture frequency, the sound frequency, or any frequency between them will not exceed 3 dB at nominal gain, and 4 dB in the a.g.c. range between nominal gain and 20 dB gain reduction.

A.G.C. range

bands I and III
bands IV and V

min. 40 dB
min. 30 dB

Power gain (see also Measuring method of power gain)

bands I and III
channel E3
channel E5
channel E12
bands IV and V
channel E21
channel E40
channel E69

min. 22 dB
typ. 28 dB
typ. 28 dB
typ. 28 dB
min. 20 dB
typ. 28 dB
typ. 27 dB
typ. 26 dB

Maximum gain difference

between any two v.h.f. channels
between any two u.h.f. channels
between any v.h.f. and u.h.f. channel

typ. 2 dB
typ. 3 dB
typ. 4 dB

Noise figure

bands I and III, except channels NZ1 and M4
channels NZ1 and M4
channel E3
channel E5
channel E12
bands IV and V
channel E21
channel E40
channel E69

max. 7 dB
max. 10 dB
typ. 4 dB
typ. 4 dB
typ. 5 dB
max. 10 dB
typ. 6 dB
typ. 6 dB
typ. 7 dB

Overloading

Input signal producing 1 dB gain
compression at nominal gain
bands I and III
bands IV and V

typ. 90 dB (μ V) into 75 Ω
typ. 90 dB (μ V) into 75 Ω

Input signal producing either a detuning
of the oscillator of + 300 kHz or
-1000 kHz or stopping of the
oscillations at nominal gain
bands I and III
bands IV and V

typ. 100 dB (μ V) into 75 Ω
typ. 100 dB (μ V) into 75 Ω

Unwanted signal characteristics

Image rejection (measured at picture carrier frequency)
bands I and III, except channels C and R4
channels C and R4
bands IV and V

min. 60 dB; typ. 70 dB
min. 55 dB
min. 44 dB; typ. 53 dB

I.F. rejection (measured at picture

carrier frequency)

channel NZ1

min. 40 dB

channel E2

min. 45 dB

channels E3 to C

min. 50 dB

band III

min. 60 dB

bands IV and V

min. 60 dB

Note: At colour sub-carrier frequency maximum 6 dB less rejection.

N \pm 4 rejection (for u.h.f. only)

Interference signal for an interference

ratio of 53 dB referred to wanted picture

carrier (picture to sound carrier ratio

of 10 dB; wanted signal 60 dB (μ V); tuner

operating at nominal gain)

typ. 75 dB (μ V) into 75 Ω

Cross modulation

Input signal producing 1% cross modulation, i.e. 1% of the modulation depth of the interfering signal is transferred to the wanted signal.

In channel cross modulation (wanted signal: picture carrier frequency; interfering signal: sound carrier frequency)

bands I and III

at nominal gain (wanted input level 60 dB (μ V))typ. 74 dB (μ V) into 75 Ω at 40 dB gain reduction (wanted input level 100 dB (μ V))typ. 94 dB (μ V) into 75 Ω

bands IV and V

at nominal gain (wanted input level 60 dB (μ V))typ. 74 dB (μ V) into 75 Ω at 30 dB gain reduction (wanted input level 90 dB (μ V))typ. 94 dB (μ V) into 75 Ω In band cross modulation (wanted signal: picture carrier of channel N; interfering signal: picture carrier of channel N \pm 2 for v.h.f. I, or channel N \pm 3 for v.h.f. III, or channel N \pm 5 for u.h.f.)

bands I and III

at nominal gain (wanted input level 60 dB (μ V))typ. 82 dB (μ V) into 75 Ω at 40 dB gain reduction (wanted input level 100 dB (μ V))typ. 94 dB (μ V) into 75 Ω

bands IV and V

at nominal gain (wanted input level 60 dB (μ V))typ. 82 dB (μ V) into 75 Ω at 30 dB gain reduction (wanted input level 90 dB (μ V))typ. 94 dB (μ V) into 75 Ω

Out of band cross modulation at nominal gain

v.h.f. I, interfering from v.h.f. III

typ. 94 dB (μ V) into 75 Ω

v.h.f. I, interfering from u.h.f.

typ. 90 dB (μ V) into 75 Ω

v.h.f. III, interfering from v.h.f. I

typ. 94 dB (μ V) into 75 Ω

v.h.f. III, interfering from u.h.f.

typ. 90 dB (μ V) into 75 Ω

u.h.f. interfering from v.h.f. I

typ. 94 dB (μ V) into 75 Ω

u.h.f. interfering from v.h.f. III

typ. 86 dB (μ V) into 75 Ω

Oscillator characteristics

Pulling

Input signal of tuned frequency producing a shift of the oscillator frequency of 10 kHz, at nominal gain

bands I and III
bands IV and V

typ. 80 dB (μ V) into 75 Ω
typ. 80 dB (μ V) into 75 Ω

Shift of oscillator frequency at a change of the supply voltage of 5%

bands I and III
bands IV and V

max. 200 kHz
max. 400 kHz

Drift of oscillator frequency

during warm-up time (after the tuner has been completely out of operation for 15 min, measured between 5 s and 15 min after switching on)

max. 250 kHz

during warm-up time (after the input stage is in operation for 15 min, measured between 2 s and 15 min after band switching)

max. 250 kHz

at a change of the ambient temperature from + 25 to + 40 °C (measured after 3 cycles from + 25 to + 55 °C)

bands I and III
bands IV and V

max. 300 kHz
max. 500 kHz

Frequency divider characteristics of version UV412

Supply voltage

+ 5 V \pm 5%

Current drawn from + 5 V supply

bands I and III
bands IV and V

max. 45 mA; typ. 35 mA
max. 55 mA; typ. 45 mA

Output voltage

3,4 to 10 V, depending on load and supply voltage

Output current

at output voltage 3,4 V
at output voltage 5 V

min. 1 mA
max. 1,5 mA

Interference signal on the i.f. output

max. 3 μ V

Note: I.F. output of the tuner terminated with the circuit shown in Fig. 10.

The output voltage is determined by the external load and the supply voltage, which is connected to this load. They should be chosen such that:

- the output-voltage rating of 10 V is not exceeded;
- the output voltage does not drop more than 1,6 V below 5 V (supply voltage of frequency divider);
- the output-voltage swing does not exceed 1 V.

Radiation by the output signal may be reduced by transporting the two complementary signals via twisted wires or a flat cable, even if only one signal is to be used to drive the subsequent circuit.

Frequency divider characteristics of the UV412/64 and UV412/256 versions

Supply voltage	+5 V \pm 10%
Current drawn from +5 V supply	max. 35 mA; typ. 25 mA
Output voltage, unloaded, measured with probe 10 M Ω /11 pF	min. 0,8 V p-p
Output impedance	typ. 1 k Ω
Output imbalance	typ. 0,1 V
Interference signal on the i.f. output	
UV412/256	max. 3 μ V
UV412/64	max. 20 μ V

Note: I.F. output of the tuner terminated with the circuit shown in Fig. 10.

I.F. circuit characteristics

Bandwidth of i.f. output circuit 5 ± 1 MHz

Note: I.F. output of the tuner terminated with the circuit shown in Fig. 10; tuning voltage 2 V; u.h.f. band switched on.

Bandwidth variation of i.f. output circuit as a result of r.f. tuning and band switching (reference: u.h.f.; tuning voltage 2 V) max. 650 kHz

Note: I.F. output of the tuner terminated with a modified circuit of Fig. 10, i.e. a 100 pF capacitor is connected in parallel with the i.f. output of the tuner.

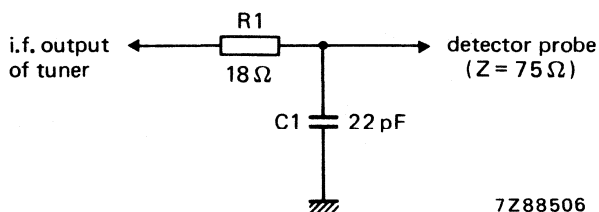

Fig. 10.

Detuning of the i.f. output circuit as a result of r.f. tuning and band switching (reference: u.h.f.; tuning voltage 2 V) max. 500 kHz

Note: I.F. output of the tuner terminated with a modified circuit of Fig. 10, i.e. a 100 pF capacitor is connected in parallel with the i.f. output of the tuner.

Minimum tuning range of i.f. output coil 33 to 40 MHz

Note: I.F. output of the tuner terminated with the circuit shown in Fig. 10.

Attenuation between i.f. injection point and i.f. output of the tuner typ. 16 dB

**UV411 SERIES
UV412 SERIES**

Miscellaneous

Radio interference

**Oscillator radiation and oscillator
voltage at the aerial terminal**

**Within the limits of C.I.S.P.R. 13
(1975) and VDE0872/7.72.**

Microphonics

**There will be no microphonics,
provided the tuner is installed
in a professional manner.**

Surge protection

Protection against voltages

max. 5 kV

Note: 10 discharges of a 470 pF capacitor into the aerial terminal.

Protection against flashes

max. 30 kV, 400 mWs

Note: A flashover circuit producing flashes with frequencies of 1 to 20 Hz for 30 s is connected to the aerial terminal.

ADDITIONAL INFORMATION

I.F. injection

Terminal 4 (supply voltage u.h.f.) can be used as i.f. injection point, provided the u.h.f. supply voltage is applied to terminal 4 via a resistor of $10\ \Omega$ (see Fig. 11). The u.h.f. band should be switched on; tuning voltage should be $2\ \text{V}$.

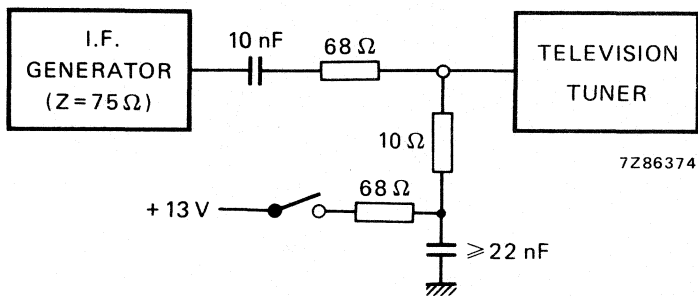

Fig. 11.

Connection of the i.f. amplifier

No special precautions are required to load and to match the i.f. output of the tuner.

Connection of supply voltages

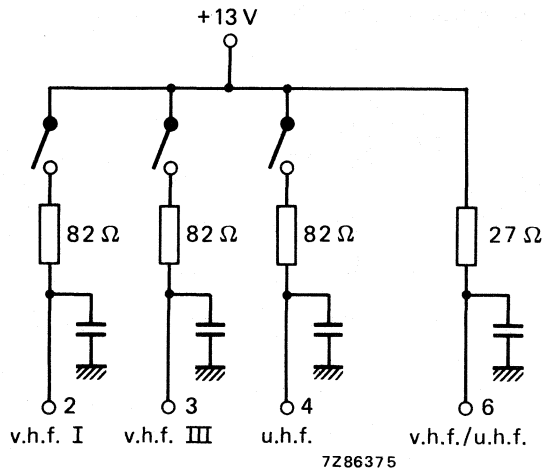

Fig. 12.

Measuring method of power gain

The i.f. output of the tuner should be terminated with the RC-circuit given in Fig. 10.

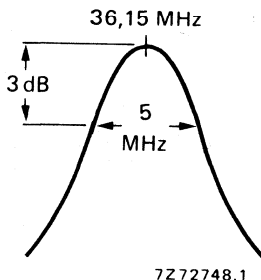

Fig. 13.

The RC-circuit roughly matches the i.f. output impedance to 75Ω at the resonant frequency of the i.f. output circuit, which should be tuned to 36,15 MHz; the bandwidth is approx. 5 MHz (Fig. 13).

Because the input and output impedances of the tuner are now 75Ω , the power gain can be measured in the conventional manner by inserting tuner and RC-circuit between a 75Ω source and a 75Ω detector.

Alignment of the i.f. output coil

The i.f. output coil should be adjusted with a brass tool with a blade as shown in Fig. 14. A suitable tool is available under catalogue number 7122 005 47680.

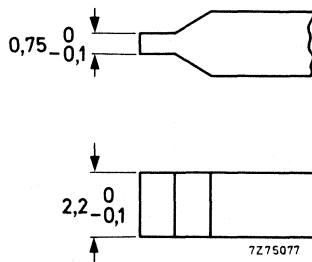

Fig. 14.

V.H.F./U.H.F. TELEVISION TUNER**QUICK REFERENCE DATA**

Systems	C.C.I.R. system D
Channels	
low v.h.f.	C1 to C5
high v.h.f.	C6 to C12
u.h.f.	C13 to C57
Intermediate frequencies	
picture	37,00 MHz
sound	30,50 MHz

APPLICATION

Designed to cover the v.h.f. and u.h.f. channels of C.C.I.R. system D.

A tuner UV412HKM/256/IEC with a frequency divider (1 : 256) is available under catalogue number 3122 237 00240. This version is suitable for digital tuning systems based on frequency synthesis.

DESCRIPTION

The UV411 HKM/IEC is a combined v.h.f./u.h.f. tuner with electronic tuning and band switching, covering the low v.h.f. band (frequency range 48 to 92 MHz), the high v.h.f. band (frequency range 167 to 224 MHz), and the u.h.f. band (frequency range 470 to 870 MHz).

Mechanically, the tuner is built on a low-loss printed-wiring board, carrying all components, in a metal housing made of a rectangular frame and front and rear covers (see Fig. 2). The common IEC aerial connector (v.h.f. and u.h.f.) is on one of the frame sides, all other connections (supply voltages, a.g.c. voltage, tuning and switching voltages, i.f. output) are made via terminals in the underside. The mounting method is shown in Fig. 3.

Electrically, the tuner consists of v.h.f. and u.h.f. parts. The v.h.f. aerial signal is fed via switchable wide band input filters to gate 1 of an input MOSFET tetrode (with internal gate protection against surge).

The input filters are provided with an i.f. and f.m. suppression circuit. The drain load of the MOSFET tetrode is formed by a double tuned switchable bandpass filter, transferring the r.f. signal to the emitter of the mixer transistor. The oscillator signal is also fed to the emitter of the mixer transistor.

The collector circuit of the mixer transistor is a single tuned i.f. resonant circuit, at the low end of which the i.f. signal is coupled out of the tuner. A test point (terminal 4) is provided for i.f. injection to align the i.f. output circuit of the tuner together with the i.f. amplifier of the television receiver. An additional test point, which is accessible through a hole in the top of the tuner, is connected to the collector of the mixer transistor.

The r.f. band pass filter and oscillator circuits are tuned by 3 tuning diodes; band switching is achieved by 5 switching diodes.

The u.h.f. part of the tuner consists of a high-pass input circuit connected to gate 1 of an input MOSFET tetrode (with internal gate protection against surge). The drain load of this MOSFET tetrode is formed by a double tuned circuit transferring the r.f. signal to the Schottky barrier mixer diode. The i.f. signal from the mixer diode is amplified by the v.h.f. mixer transistor, now operating as an i.f. amplifier.

The r.f. band pass filter and oscillator circuits are tuned by 3 tuning diodes.

In all bands the tuner is gain controlled via gate 2 of the input MOSFET tetrodes.

MECHANICAL DATA

Dimensions in mm

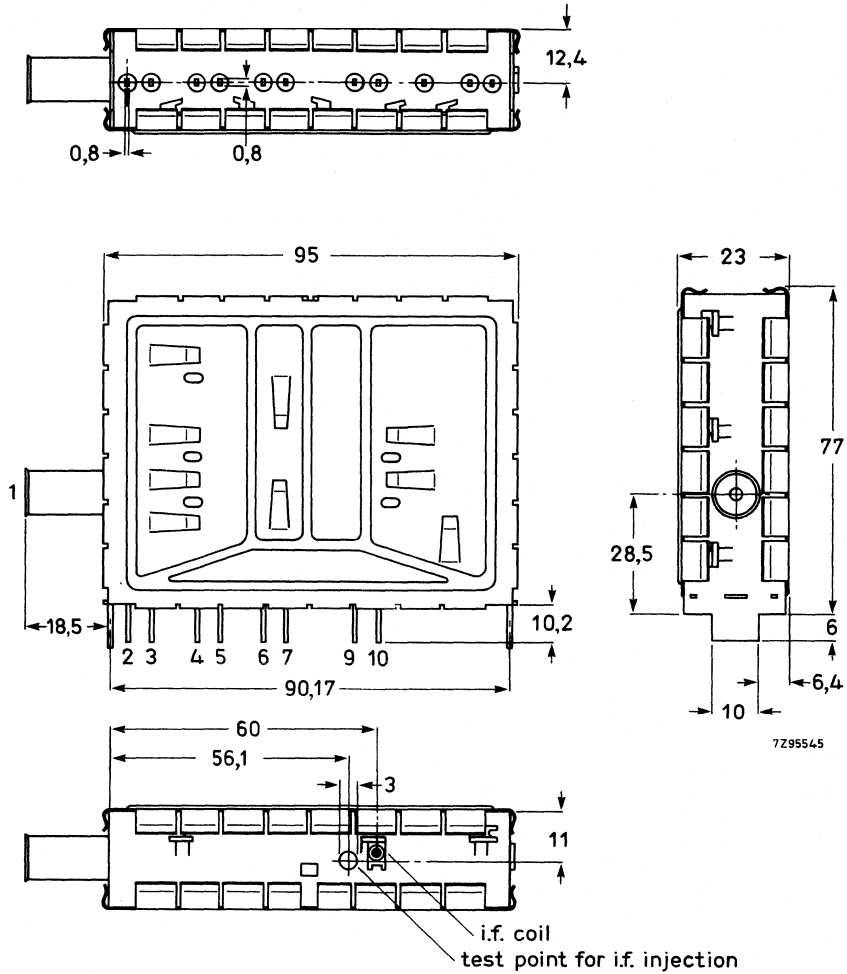

Fig. 2a.

Terminal

- 1 = aerial
- 2 = supply voltage, low v.h.f., + 12 V
- 3 = supply voltage, high v.h.f., + 12 V
- 4 = supply voltage, u.h.f., + 12 V
- 5 = a.g.c. voltage, + 9,2 to + 0,85 V
- 6 = supply voltage, v.h.f. and u.h.f., + 12 V

- 7 = tuning voltage, + 1 to + 28 V
- 9 = i.f. output
- 10 = earth

Fig. 2b I.F. output coil.
Torque for alignment: 2 to 15 mNm.
Press-through force: ≥ 10 N.

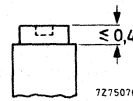

Mass approx. 127 g

Mounting

The tuner may be mounted by soldering it on to a printed-wiring board, using the piercing diagram shown in Fig. 3. (The tuner may also be mounted by means of a bracket. Information will be supplied upon request.) The tuner may be mounted anywhere in the receiver and there are no restrictions on orientation.

The solderability of the terminals and mounting tabs is according to IEC 68-2, test Ta (230 ± 10 °C, $2 \pm 0,5$ s). The resistance to soldering heat is according to IEC 68-2, test Tb (260 ± 5 °C, 10 ± 1 s).

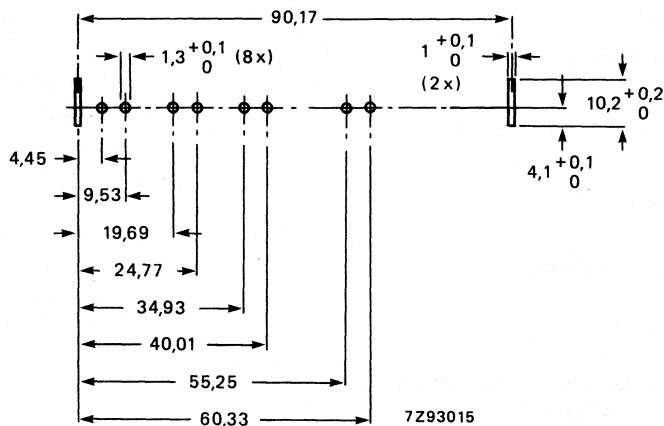

Fig. 3 Piercing diagram viewed from solder side of board. Unless otherwise stated the tolerance is $\pm 0,05$ mm.

ELECTRICAL DATA

Unless otherwise specified all electrical values apply at an ambient temperature of 25 ± 5 °C, a relative humidity of $60 \pm 15\%$, a supply voltage of $12 \pm 0,3$ V and an a.g.c. voltage of $9,2 \pm 0,2$ V.

General**Semiconductors, v.h.f. bands**

r.f. amplifier	BF982
mixer	BF324
oscillator	BF926
tuning diodes	3 x BB809
switching diodes	5 x BA482/483/484
d.c. blocking diodes	2 x BAW62

Semiconductors, u.h.f. bands

r.f. amplifier	BF980
oscillator	BF970
mixer	1SS99
tuning diodes	3 x BB405B
surge protection diodes (frequency divider)	2 x BAV10 SP4653 or SP4632)

Ambient temperature range

operating	0 to + 55 °C
storage	-25 to + 70 °C

Relative humidity

max. 95%

Voltages and currentsSupply voltage + 12 V \pm 10%**Current drawn from + 12 V supply**

v.h.f. bands	max. 55 mA; typ. 44 mA
u.h.f. bands	max. 50 mA; typ. 40 mA

Bandswitching

For operation in all bands the supply voltage is permanently connected to terminal 6. Additionally the supply voltage is connected to:

- terminal 2 for operation in low v.h.f. band
- terminal 3 for operation in high v.h.f. band
- terminal 4 for operation in u.h.f. bands

A.G.C. voltage (Figs 4, 5 and 6)

voltage range	+ 9,2 to + 0,85 V
voltage at nominal gain	+ 9,2 \pm 0,5 V
voltage at 40 dB gain reduction	
low v.h.f. band	typ. 3 V
high v.h.f. band	typ. 1,5 V
voltage at 30 dB gain reduction	typ. 2 V

Note: A.G.C. voltages between 0 and + 10,5 V may be applied without risk of damage.

A.G.C. current

max. 0,3 mA

Slope of a.g.c. characteristic,

at the end of the specified a.g.c. range

v.h.f. bands	typ. 25 dB/V
u.h.f. bands	typ. 50 dB/V

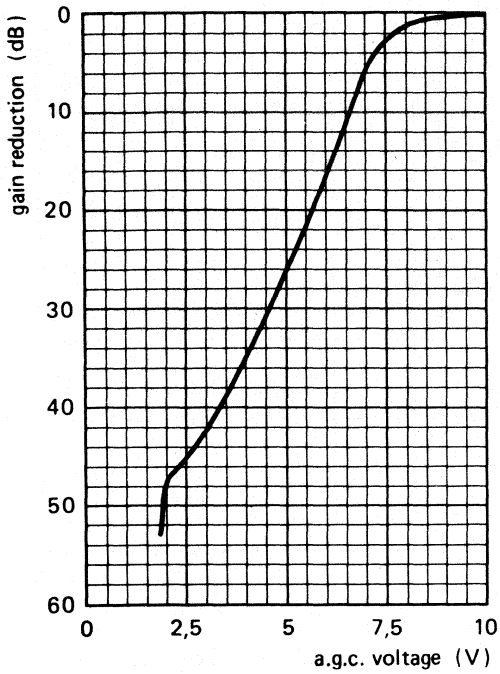

Fig. 4 Typical a.g.c. characteristic, low v.h.f. band.

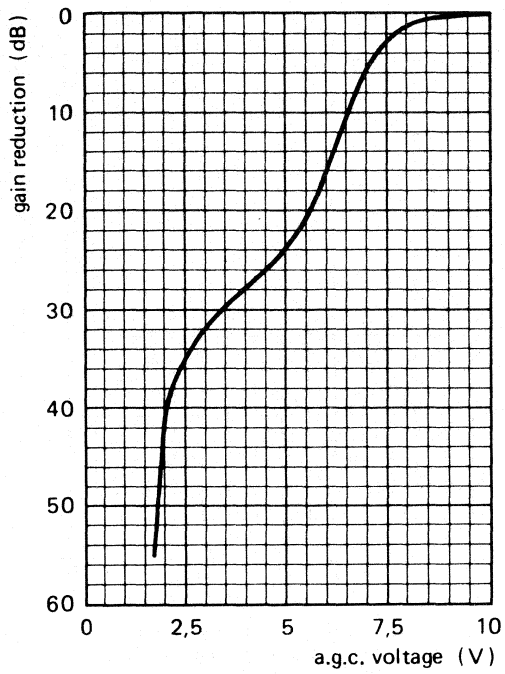

Fig. 5 Typical a.g.c. characteristic, high v.h.f. band.

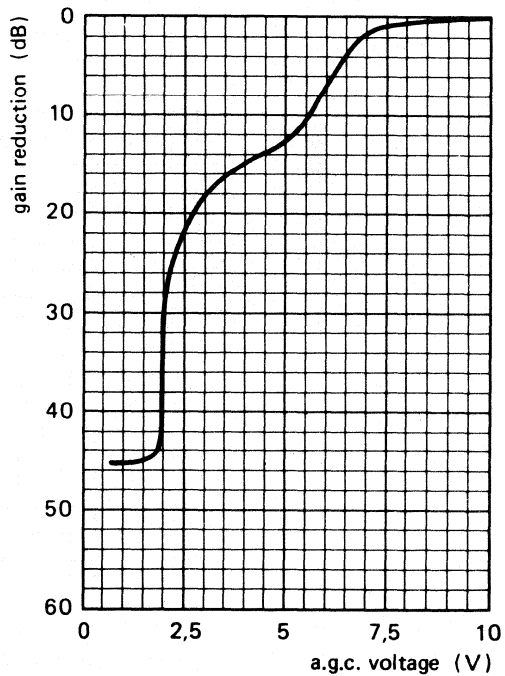

Fig. 6 Typical a.g.c. characteristic, u.h.f. bands.

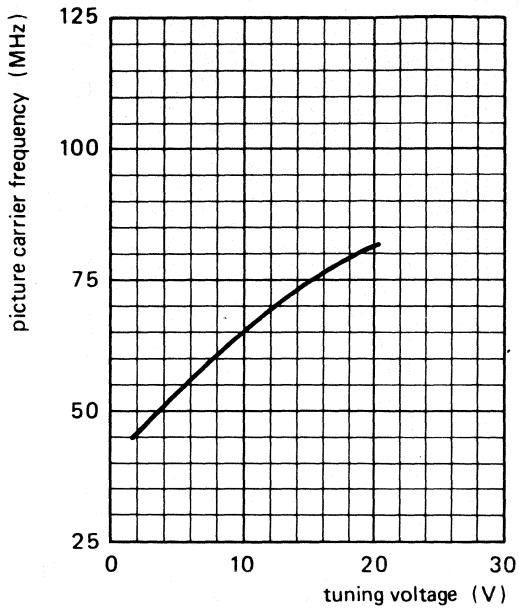

Fig. 7 Typical tuning characteristic, low v.h.f. band.

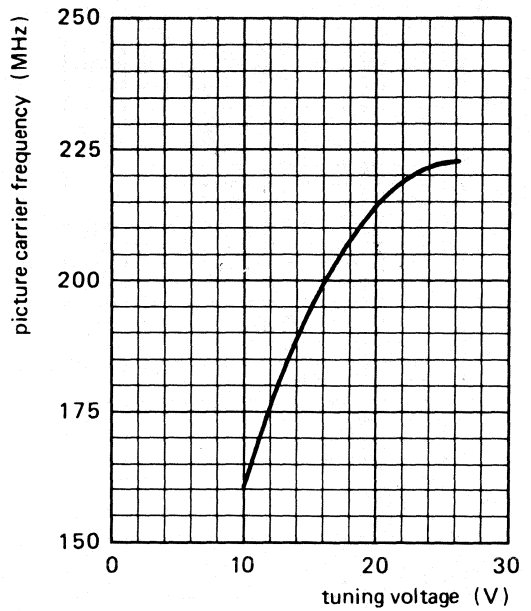

Fig. 8 Typical tuning characteristic, high v.h.f. band.

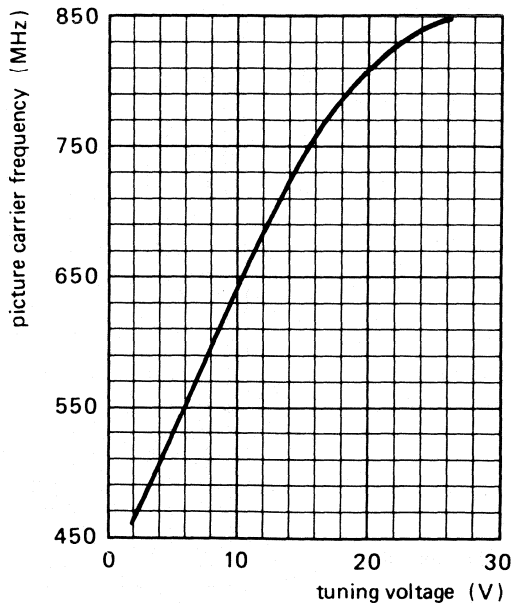

Fig. 9 Typical tuning characteristic, u.h.f. bands.

Tuning voltage range (Figs 7, 8 and 9) + 1 to + 28 V

Current drawn from 28 V tuning voltage supply

at $T_{amb} = 25\text{ }^{\circ}\text{C}$ max. 0,5 μA
 at $T_{amb} = 55\text{ }^{\circ}\text{C}$ max. 2 μA

Note: The source impedance of the tuning voltage offered to terminal 7 must be maximum 47 k Ω .

Slope of tuning characteristic

low v.h.f. band, channel C1	3 MHz/V	} typical values
channel C5	1 MHz/V	
high v.h.f. band, channel C6	6 MHz/V	
channel C12	3 MHz/V	
u.h.f. bands, channel C13	22 MHz/V	
channel C56	4 MHz/V	

Frequencies

Frequency ranges

low v.h.f. band

channel C1 (picture carrier 49,75 MHz) to channel C5 (picture carrier 85,25 MHz).

Margin at the extreme channels: min. 1,5 MHz.

high v.h.f. band

channel C6 (picture carrier 168,25 MHz) to channel C12 (picture carrier 216,25 MHz).

Margin at the extreme channels: min. 2 MHz.

u.h.f. bands

channel C13 (picture carrier 471,25 MHz) to channel C57 (picture carrier 863,25 MHz).

Margin at the extreme channels: min. 3 MHz.

Intermediate frequencies

picture

37,0 MHz

sound

30,5 MHz

The oscillator frequency is higher than the aerial signal frequency.

Wanted signal characteristics

Input impedance

75 Ω

V.S.W.R. and reflection coefficient

(values between picture and sound carrier, as well as values at picture carrier)

v.s.w.r.

at nominal gain

during gain control

v.h.f. bands

max. 4,5

max. 5,5

u.h.f. bands

max. 5

max. 7

reflection coefficient

v.h.f. bands

max. 64%

max. 69%

u.h.f. bands

max. 66%

max. 75%

R.F. curves, bandwidth

low v.h.f. band

typ. 11 MHz

high v.h.f. band

typ. 13 MHz

u.h.f. bands

typ. 20 MHz

R.F. curves, tilt

on any channel the amplitude difference between the top of the r.f. resonant curve and the picture frequency, the sound frequency, or any frequency between them will not exceed 3 dB at nominal gain, and 4 dB in the a.g.c. range between nominal gain and 20 dB gain reduction.

A.G.C. range

v.h.f. bands

min. 40 dB

u.h.f. bands

min. 30 dB

Power gain (see also Measuring method of power gain)

v.h.f. bands

min. 22 dB

channel C2

typ. 28 dB

channel C7

typ. 28 dB

channel C12

typ. 28 dB

u.h.f. bands

min. 20 dB

channel C13

typ. 28 dB

channel C27

typ. 27 dB

channel C56

typ. 26 dB

Maximum gain difference

between any two v.h.f. channels

typ. 2 dB

between any two u.h.f. channels

typ. 3 dB

between any v.h.f. and u.h.f. channel

typ. 4 dB

Noise figure

v.h.f. bands

max. 8 dB

channel C2

typ. 4 dB

channel C7

typ. 4 dB

channel C12

typ. 5 dB

u.h.f. bands

max. 10 dB

channel C13

typ. 6 dB

channel C27

typ. 6 dB

channel C56

typ. 7 dB

Overloading

Input signal producing 1 dB gain

compression at nominal gain

v.h.f. bands

typ. 90 dB (μ V) into 75 Ω

u.h.f. bands

typ. 90 dB (μ V) into 75 Ω

Input signal producing either a detuning

of the oscillator of + 300 kHz or

- 1000 kHz or stopping of the

oscillations at nominal gain

v.h.f. bands

typ. 100 dB (μ V) into 75 Ω

u.h.f. bands

typ. 100 dB (μ V) into 75 Ω

Unwanted signal characteristics

Image rejection (measured at picture carrier frequency)

v.h.f. bands, except channel C5

min. 60 dB; typ. 70 dB

channel C5

min. 55 dB; typ. 59 dB

u.h.f. bands, channels C13 up to C50

min. 44 dB; typ. 53 dB

channels C51 up to C57

min. 40 dB; typ. 44 dB

I.F. rejection (measured at picture carrier frequency)

low v.h.f. band	
channel C1	min. 45 dB
channels C2 up to C5	min. 50 dB
high v.h.f. band	min. 60 dB
u.h.f. bands	min. 60 dB

Note: At colour sub-carrier frequency maximum 6 dB less rejection.

Cross modulation

Input signal producing 1% cross modulation, i.e. 1% of the modulation depth of the interfering signal is transferred to the wanted signal.

In channel cross modulation (wanted signal: picture carrier frequency; interfering signal: sound carrier frequency)

v.h.f. bands

at nominal gain (wanted input level 60 dB (μ V))	typ. 74 dB (μ V) into 75 Ω
at 40 dB gain reduction (wanted input level 100 dB (μ V))	typ. 94 dB (μ V) into 75 Ω

u.h.f. bands

at nominal gain (wanted input level 60 dB (μ V))	typ. 74 dB (μ V) into 75 Ω
at 30 dB gain reduction (wanted input level 90 dB (μ V))	typ. 94 dB (μ V) into 75 Ω

In band cross modulation (wanted signal: picture carrier of channel N; interfering signal: picture carrier of channel N \pm 2 for low v.h.f., or channel N \pm 3 for high v.h.f., or channel N \pm 5 for u.h.f.)

v.h.f. bands

at nominal gain (wanted input level 60 dB (μ V))	typ. 82 dB (μ V) into 75 Ω
at 40 dB gain reduction (wanted input level 100 dB (μ V))	typ. 94 dB (μ V) into 75 Ω

u.h.f. bands

at nominal gain (wanted input level 60 dB (μ V))	typ. 82 dB (μ V) into 75 Ω
at 30 dB gain reduction (wanted input level 90 dB (μ V))	typ. 94 dB (μ V) into 75 Ω

Out of band cross modulation at nominal gain

low v.h.f., interfering from high v.h.f.	typ. 94 dB (μ V) into 75 Ω
low v.h.f., interfering from u.h.f.	typ. 90 dB (μ V) into 75 Ω
high v.h.f., interfering from low v.h.f.	typ. 94 dB (μ V) into 75 Ω
high v.h.f., interfering from u.h.f.	typ. 90 dB (μ V) into 75 Ω
u.h.f. interfering from low v.h.f.	typ. 94 dB (μ V) into 75 Ω
u.h.f. interfering from high v.h.f.	typ. 86 dB (μ V) into 75 Ω

Oscillator characteristics**Pulling**

Input signal of tuned frequency producing a shift of the oscillator frequency of 10 kHz, at nominal gain

v.h.f. bands

typ. 80 dB (μ V) into 75 Ω

u.h.f. bands

typ. 80 dB (μ V) into 75 Ω

Shift of oscillator frequency at a change of the supply voltage of 5%

v.h.f. bands

max. 200 kHz

u.h.f. bands

max. 400 kHz

Drift of oscillator frequency

during warm-up time (after the tuner has been completely out of operation for 15 min, measured between 5 s and 15 min after switching on)

max. 250 kHz

during warm-up time (after the input stage is in operation for 15 min, measured between 2 s and 15 min after band switching)

max. 250 kHz

at a change of the ambient temperature from + 25 to + 40 °C (measured after 3 cycles from + 25 to + 55 °C)

v.h.f. bands

max. 300 kHz

u.h.f. bands

max. 500 kHz

I.F. circuit characteristics

Bandwidth of i.f. output circuit

5 ± 1 MHz

Note: I.F. output of the tuner terminated with the circuit shown in Fig. 10; tuning voltage 2 V; u.h.f. band switched on.

Bandwidth variation of i.f. output circuit as a result of r.f. tuning and band switching (reference: u.h.f.; tuning voltage 2 V)

max. 650 kHz

Note: I.F. output of the tuner terminated with a modified circuit of Fig. 10, i.e. a 100 pF capacitor is connected in parallel with the i.f. output of the tuner. I.F. output adjusted to 33,75 MHz.

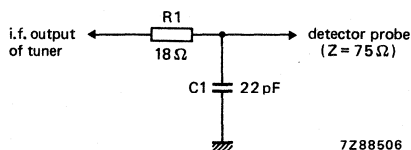

Fig. 10.

Detuning of the i.f. output circuit as a result of r.f. tuning and band switching (reference: u.h.f.; tuning voltage 2 V) max. 500 kHz

Note: I.F. output of the tuner terminated with a modified circuit of Fig. 10, i.e. a 100 pF capacitor is connected in parallel with the i.f. output of the tuner.

Minimum tuning range of i.f. output coil 30 to 39 MHz

Note: I.F. output of the tuner terminated with the circuit shown in Fig. 10.

Attenuation between i.f. injection point and i.f. output of the tuner typ. 16 dB

Miscellaneous

Radio interference

Oscillator radiation and oscillator voltage at the aerial terminal

Within the limits of C.I.S.P.R. 13 (1975) and VDE 0872/7.72.

Microphonics

There will be no microphonics, provided the tuner is installed in a professional manner.

Surge protection

Protection against voltages

max. 5 kV

Note: 10 discharges of a 470 pF capacitor into the aerial terminal.

Protection against flashes

max. 30 kV, 400 mWs

Note: A flashover circuit producing flashes with frequencies of 1 to 20 Hz for 30 s is connected to the aerial terminal.

ADDITIONAL INFORMATION

I.F. injection

Terminal 4 (supply voltage u.h.f.) can be used as i.f. injection point, provided the u.h.f. supply voltage is applied to terminal 4 via a resistor of $10\ \Omega$ (see Fig. 11). The u.h.f. band should be switched on; tuning voltage should be $2\ \text{V}$.

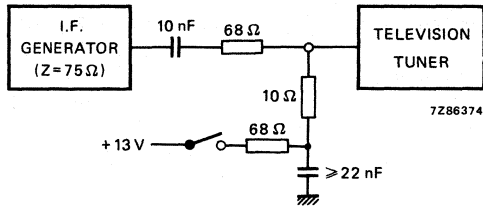

Fig. 11.

Connection of the i.f. amplifier

No special precautions are required to load and to match the i.f. output of the tuner.

Connection of supply voltages

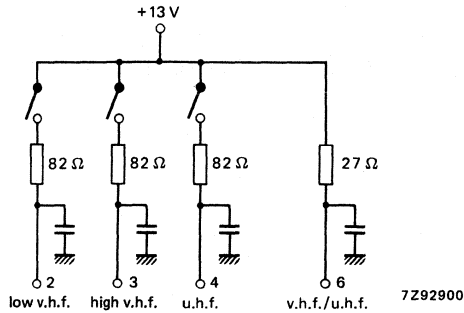

Fig. 12.

Measuring method of power

The i.f. output of the tuner should be terminated with the RC-circuit given in Fig. 10.

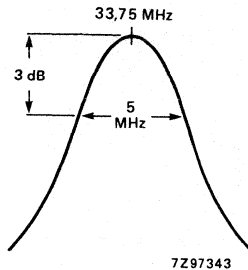

Fig. 13.

The RC-circuit roughly matches the i.f. output impedance to 75Ω at the resonant frequency of the i.f. output circuit, which should be tuned to 33,75 MHz; the bandwidth is approx. 5 MHz (Fig. 13).

Because the input and output impedances of the tuner are now 75Ω , the power gain can be measured in the conventional manner by inserting tuner and RC-circuit between a 75Ω source and a 75Ω detector.

Alignment of the i.f. output coil

The i.f. output coil should be adjusted with a plastic tool which has a cross head as shown in Fig. 14.

A suitable tool for automatic alignment is available:

holder catalogue number 7122 005 47910

cross-head catalogue number 3122 131 63390.

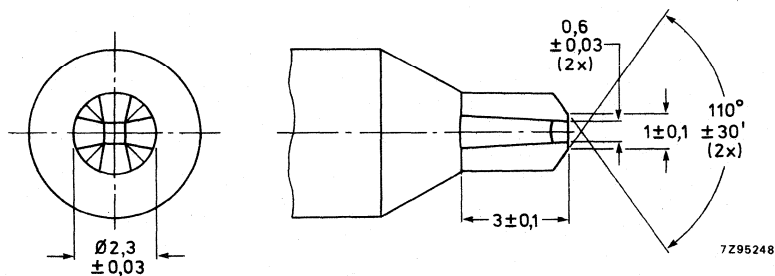

Fig. 14.

V.H.F./U.H.F. TELEVISION TUNERS

QUICK REFERENCE DATA

Systems	C.C.I.R. systems B and G
Channels	
low v.h.f.	E2 to S1
high v.h.f.	S2 to S20
u.h.f.	E21 to E69
Intermediate frequencies	
picture	38,9 MHz
sound	33,4 MHz

APPLICATION

Designed to cover the v.h.f. and u.h.f. channels of C.C.I.R. systems B and G, with extended v.h.f. frequency ranges.

The tuner UV418 is equipped with a frequency divider, which makes it suitable for digital tuning systems based on frequency synthesis; otherwise this tuner is equal to type UV417.

Both tuners comply with the requirements of radiation, signal handling capability, and immunity from radiated interference of Amtsblatt DBP69/1981, when installed professionally in an adequate TV receiver.

Available versions

type number	aerial input connector	frequency divider (IC)	division ratio	catalogue number
UV417	phono	—	—	3112 218 52660
UV417/IEC	IEC	—	—	3112 218 52690
UV418/256	phono	8-pin	256	3112 218 52720
UV418/256/IEC	IEC	8-pin	256	3112 218 52780
UV418/64	phono	8-pin	64	3112 218 52750
UV418/64/IEC	IEC	8-pin	64	3112 218 52810

DESCRIPTION

The UV417 and UV418 are combined v.h.f./u.h.f. tuners with electronic tuning and band switching, covering the low v.h.f. band (frequency range 47 to 111 MHz), the high v.h.f. band (frequency range 111 to 300 MHz), and the u.h.f. band (frequency range 470 to 860 MHz).

Mechanically, the tuners are built on a low-loss printed-wiring board, carrying all components, in a metal housing made of a rectangular frame and front and rear covers (see Fig. 2). The common phono aerial connector (v.h.f. and u.h.f.) is on one of the frame sides, all other connections (supply voltages, a.g.c. voltage, tuning and switching voltages, i.f. output) are made via terminals in the underside. The mounting method is shown in Fig. 3.

Electrically, the tuners consist of v.h.f. and u.h.f. parts. The v.h.f. aerial signal is fed via switchable wideband low v.h.f. and high v.h.f. input filters to gate 1 of an input MOSFET tetrode (with internal gate protection against surge).

The input filters are provided with an i.f. suppression circuit. The drain load of the MOSFET tetrode is formed by a double tuned switchable bandpass filter, transferring the r.f. signal to the emitter of the mixer transistor. The oscillator signal is also fed to the emitter of the mixer transistor (T.P.1.).

The collector circuit of the mixer transistor is a single tuned i.f. resonant circuit, where at the low impedance side the i.f. signal is coupled out of the tuner. A test point, which is accessible through a hole in the top of the frame is provided for i.f. injection to align the i.f. output circuit of the tuner together with the i.f. amplifier of the television receiver. An additional test point, which is accessible through a hole in the top of the tuner, is connected to the collector of the mixer transistor (T.P.1.).

The input, the r.f. band pass filter and oscillator circuits are tuned by 5 tuning diodes; band switching is achieved by 5 switching diodes.

The u.h.f. part of the tuner consists of a high-pass input circuit connected to gate 1 of an input MOSFET tetrode (with internal gate protection against surge). The drain load of this MOSFET tetrode is formed by a double tuned circuit transferring the r.f. signal to the Schottky barrier mixer diode. The i.f. signal from the mixer diode is amplified by the v.h.f. mixer transistor, now operating as an i.f. amplifier.

The input, the r.f. bandpass filter and oscillator circuits are tuned by 4 tuning diodes.

In all bands the tuner is gain controlled via gate 2 of the input MOSFET tetrode.

The electrical circuit of the UV418 series is extended with a frequency divider (division ratio of 64 or 256), which inputs are connected to the v.h.f. and u.h.f. oscillator. The complementary outputs are connected to terminals 12 and 13.

MECHANICAL DATA

Dimensions in mm

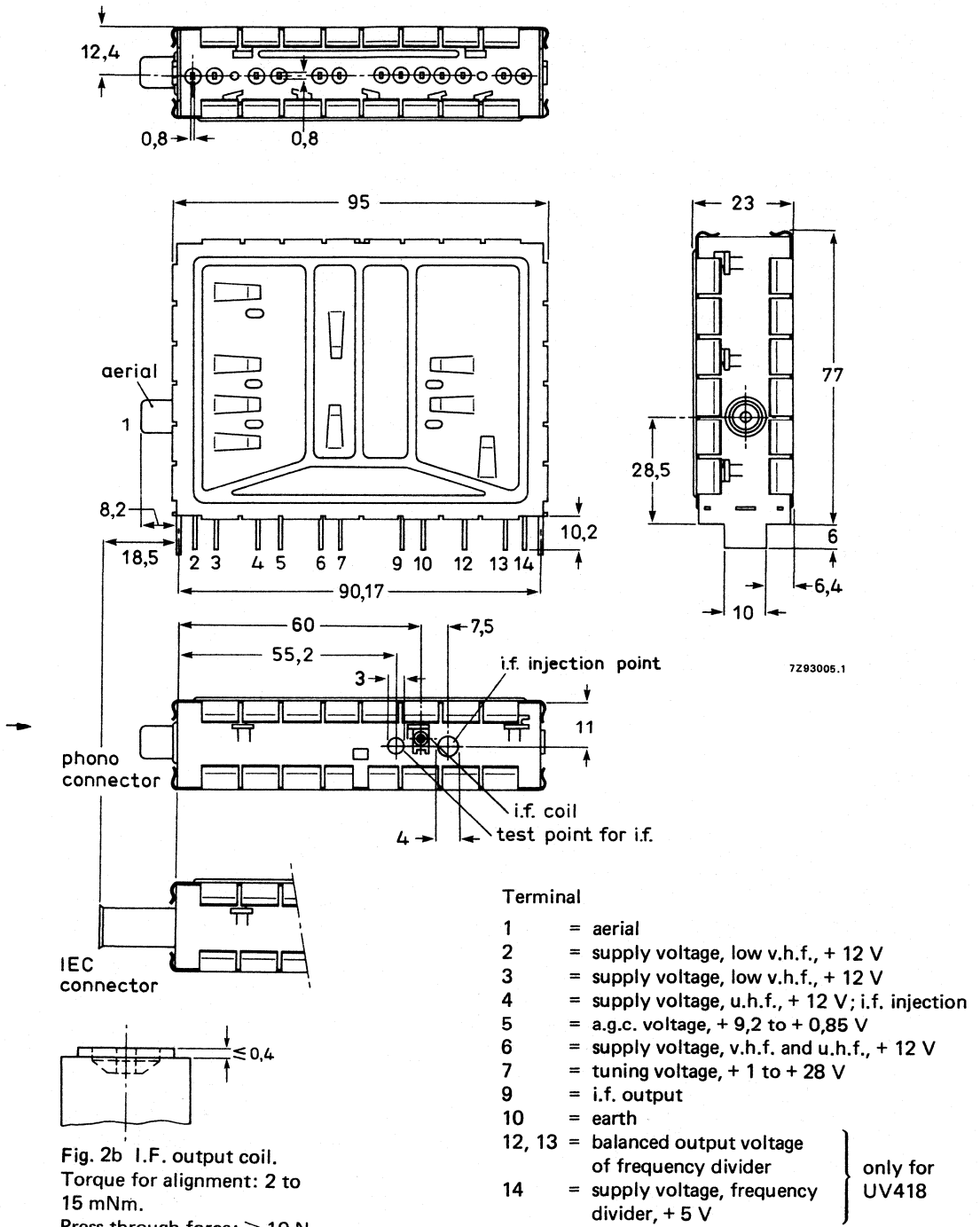

Fig. 2b I.F. output coil.
Torque for alignment: 2 to 15 mNm.
Press-through force: ≥ 10 N.

Mass approx. 127 g

Mounting

The tuner may be mounted by soldering it on to a printed-wiring board, using the piercing diagram shown in Fig. 3. (The tuner may also be mounted by means of a bracket. Information will be supplied upon request). The tuner may be mounted anywhere in the receiver and there are no restrictions on orientation.

The solderability of the terminals and mounting tabs is according to IEC 68-2-20, test Ta (230 ± 10 °C, $2 \pm 0,5$ s). The resistance to soldering heat is according to IEC 68-2-20, test Tb (260 ± 5 °C, 10 ± 1 s).

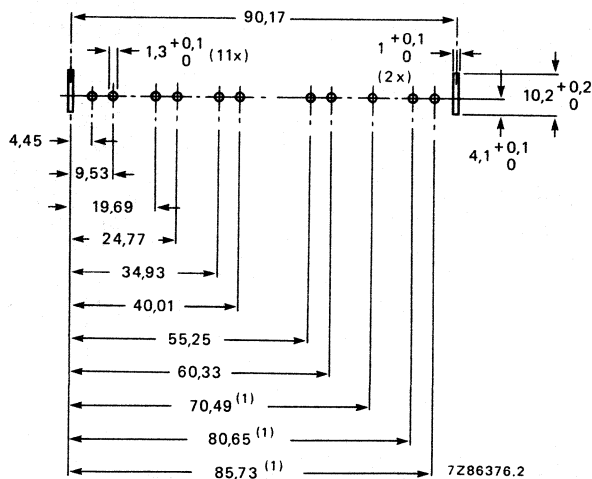

(1) Only for UV418.

Fig. 3 Piercing diagram viewed from solder side of board. Unless otherwise stated the tolerance is $\pm 0,05$ mm.

Marking

The tuner is provided with a label showing the following date:

- type number
- catalogue number
- code for factory of origin
- change code
- code for year and week of production

ELECTRICAL DATA

Unless otherwise specified all electrical values apply at an ambient temperature of 25 ± 5 °C, a relative humidity of $60 \pm 15\%$, a supply voltage of $12 \pm 0,3$ V and an a.g.c. voltage of $9,2 \pm 0,2$ V.

General

Semiconductors, v.h.f. bands

r.f. amplifier	BF980
mixer	BF324
oscillator	BF926
tuning diodes	4 x BB909, 1 x BB405
switching diodes	2 x BA482, 2 x BA483, 1 x BA484
d.c. blocking diodes	2 x BAW62

Semiconductors, u.h.f. bands

r.f. amplifier	BF980
oscillator	BF970
mixer	1SS99
tuning diodes	4 x BB405B
frequency divider ÷ 256	SP4653
frequency divider ÷ 64	SP4632

Ambient temperature range

operating	0 to + 55 °C
storage	-25 to + 70 °C

Relative humidity

max. 95%

Voltages and currents

Supply voltage $+ 12$ V $\pm 10\%$

The supply voltage of band switching (terminals 2, 3 and 4) may never deviate more than $+ 10\%/-5\%$ from the unswitched supply voltage (terminal 6) within the specified margin of $\pm 10\%$.

Ripple susceptibility on supply voltages t.b.e.

The ripple susceptibility is defined as the peak-to-peak value of a sinewave signal (20 Hz - 500 kHz) on the supply voltages causing an amplitude modulation with a modulation depth of 0,28% on the picture carrier after passing the Nyquist curve of the i.f. filter of a TV receiver.

Current drawn from + 12 V supply

v.h.f. bands	max. 42 mA
u.h.f. bands	max. 42 mA

Band switching

max. 11 mA

For operation in all bands the supply voltage is permanently connected to terminal 6. Additionally the supply voltage is connected to:

- terminal 2 for operation in low v.h.f. band.
- terminal 3 for operation in high v.h.f. band.
- terminal 4 for operation in u.h.f. bands.

A.G.C. voltage (Note: voltages between 0 and + 10,5 V may be applied without risk of damage.)

voltage range	+ 9,2 to + 0,85 V
voltage at nominal gain	+ 9,2 \pm 0,5 V
voltage at 40 dB gain reduction	
low v.h.f. band	typ. 3 V
high v.h.f. band	typ. 1,5 V
voltage at 30 dB gain reduction	
u.h.f.	typ. 2 V

A.G.C. current	max. 0,3 mA
Slope of a.g.c. characteristic, at the end of the specified a.g.c. range	
v.h.f. bands	typ. 25 dB/V
u.h.f. bands	typ. 50 dB/V
Tuning voltage range	+ 1 to + 28 V
Current drawn from 28 V tuning voltage supply	
at $T_{amb} = 25\text{ }^{\circ}\text{C}$ and 60% R.H.	max. 0,5 μA
at $T_{amb} = 25\text{ }^{\circ}\text{C}$ and 95% R.H.	max. 2 μA
at $T_{amb} = 55\text{ }^{\circ}\text{C}$ and 60% R.H.	max. 2 μA

Note: The source impedance of the tuning voltage offered to terminal 7 is maximum 47 k Ω .

Slope of tuning characteristic		
low v.h.f. band, channel E2	5 MHz/V	} typical values
channel S1	1 MHz/V	
high v.h.f. band, channel S2	7 MHz/V	
channel S20	2 MHz/V	
u.h.f. band, channel E21	22 MHz/V	
channel E69	5 MHz/V	

Frequencies

Frequency ranges	
low v.h.f. band	channel E2 (picture carrier 48,25 MHz) to channel S1 picture carrier 105,25 MHz). Margin at the extreme channels: min. 1,5 MHz.
high v.h.f. band	channel S2 (picture carrier 112,25 MHz) to channel S20 (picture carrier 294,25 MHz). Margin at the extreme channels: min. 2 MHz.
u.h.f. bands	channel E21 (picture carrier 471,25 MHz) to channel E69 (picture carrier 855,25 MHz). Margin at the extreme channels: min. 3 MHz.
Intermediate frequencies	
picture	38,9 MHz
sound	33,4 MHz
	The oscillator frequency is higher than the aerial signal frequency.

Wanted signal characteristics

Input impedance	75 Ω	
V.S.W.R. and reflection coefficient (values between picture and sound carrier, as well as values at picture carrier)		
v.s.w.r.	at nominal gain	during gain control
v.h.f.	max. 4,5	max. 5,5
u.h.f.	max. 5	max. 7
reflection coefficient		
v.h.f.	max. 63%	max. 69%
u.h.f.	max. 66%	max. 75%

ELECTRICAL DATA (continued)

R.F. curves, bandwidth	
low v.h.f. band	typ. 10 MHz
high v.h.f. band	typ. 13 MHz
u.h.f. bands	typ. 18 MHz
R.F. curves, tilt	on any channel the amplitude difference between the top of the r.f. resonant curve and the picture frequency, the sound frequency, or any frequency between them will not exceed 3 dB at nominal gain, and 4 dB in the a.g.c. range between nominal gain and 20 dB gain reduction.
A.G.C. range	
v.h.f.	min. 40 dB
u.h.f.	min. 30 dB
Power gain (see also Measuring method of power gain)	
v.h.f. bands (channels S2 to S4 excluded)	min. 20 dB
channels S2 and S3	min. 17 dB
channel S4	min. 19 dB
channel E3	typ. 27 dB
→ channel E5	typ. 27 dB
channel E12	typ. 27 dB
u.h.f. bands	min. 16 dB
channel E21	typ. 28 dB
→ channel E40	typ. 27 dB
channel E69	typ. 26 dB
Maximum gain difference	
between any two v.h.f. channels	typ. 8 dB
between any two u.h.f. channels	typ. 4 dB
between any v.h.f. and u.h.f. channel	typ. 8 dB
Noise figure	
v.h.f. bands	
E channels	max. 8 dB
S channels	max. 10 dB
channel E3	typ. 5 dB
→ channel E5	typ. 5 dB
channel E12	typ. 6 dB
u.h.f. bands	max. 13 dB
channel E21	typ. 7 dB
→ channel E40	typ. 7 dB
channel E69	typ. 8 dB
Overloading	
Input signal producing 1 dB gain compression at nominal gain	
v.h.f.	typ. 90 dB (μ V) into 75 Ω
u.h.f.	typ. 90 dB (μ V) into 75 Ω
Input signal producing either a detuning of the oscillator of + 300 kHz or -1000 kHz or stopping of the oscillations at nominal gain	
v.h.f.	typ. 100 dB (μ V) into 75 Ω
u.h.f.	typ. 100 dB (μ V) into 75 Ω

Unwanted signal characteristics

Image rejection (measured at picture carrier frequency)

v.h.f. bands

min. 60 dB; typ. 70 dB

u.h.f. bands, except channels E61 to E69

min. 50 dB; typ. 62 dB

channels E61 to E69

min. 44 dB

I.F. rejection (measured at picture carrier frequency)

low v.h.f., except channel E2

min. 50 dB

channel E2

min. 45 dB

high v.h.f.

min. 60 dB

u.h.f.

min. 60 dB

Note: At colour sub-carrier frequency maximum 6 dB less rejection

Cross modulation

Input signal producing 1% cross modulation, i.e. 1% of the modulation depth of the interfering signal is transferred to the wanted signal.

In channel cross modulation (wanted signal: picture carrier frequency; interfering signal: sound carrier frequency)

v.h.f. bands

at nominal gain (wanted input level 60 dB (μV))typ. 84 dB (μV) into 75 Ω at 40 dB gain reduction (wanted input level 100 dB (μV))typ. 100 dB (μV) into 75 Ω

u.h.f. bands

at nominal gain (wanted input level 60 dB (μV))typ. 84 dB (μV) into 75 Ω at 30 dB gain reduction (wanted input level 90 dB (μV))typ. 100 dB (μV) into 75 Ω In band cross modulation (wanted signal: picture carrier of channel N; interfering signal: picture carrier of channel $N \pm 2$ for low v.h.f., or channel $N \pm 3$ for high v.h.f., or channel $N \pm 5$ for u.h.f.)

v.h.f. bands

at nominal gain (wanted input level 60 dB (μV))typ. 92 dB (μV) into 75 Ω at 40 dB gain reduction (wanted input level 100 dB (μV))typ. 100 dB (μV) into 75 Ω

u.h.f. bands

at nominal gain (wanted input level 60 dB (μV))typ. 92 dB (μV) into 75 Ω at 30 dB gain reduction (wanted input level 90 dB (μV))typ. 100 dB (μV) into 75 Ω

Out of band cross modulation at nominal gain

low v.h.f., interfering from high v.h.f.

typ. 100 dB (μV) into 75 Ω

low v.h.f., interfering from u.h.f.

typ. 100 dB (μV) into 75 Ω

high v.h.f., interfering from low v.h.f.

typ. 100 dB (μV) into 75 Ω

high v.h.f., interfering from u.h.f.

typ. 100 dB (μV) into 75 Ω

u.h.f. interfering from low v.h.f.

typ. 100 dB (μV) into 75 Ω

u.h.f. interfering from high v.h.f.

typ. 100 dB (μV) into 75 Ω **Unwanted signal handling capability (visibility test)**

For the channel combinations

v.h.f.: $N \pm 1$, $N \pm 5$, $N + 11$ u.h.f.: $N \pm 1$, $N \pm 5$, $N + 9$

The tuner meets the requirements of "Amtsblatt" DBP69/1981, item 5.1.2., when measured in an adequate TV receiver. The a.g.c. circuit of the TV receiver has to be adjusted with an input signal of 74 dB (μV) on channel E60 in such a way, that the gain of the tuner is decreased by 10 dB.

ELECTRICAL DATA (continued)

Oscillator characteristics

Pulling

Input signal of tuned frequency producing a shift of the oscillator frequency of 10 kHz, at nominal gain

v.h.f. bands

typ. 85 dB (μ V) into 75 Ω

u.h.f. bands

typ. 85 dB (μ V) into 75 Ω

Shift of oscillator frequency at a change of the supply voltage of 5%

v.h.f. bands

max. 400 kHz

u.h.f. bands

max. 500 kHz

When using the supply circuit of Fig. 12 an additional oscillator frequency shift will occur during a.g.c.

v.h.f. bands

max. 150 kHz

u.h.f. bands

max. 150 kHz

Drift of oscillator frequency

during warm-up time (after the tuner has been completely out of operation for 15 min, measured between 5 s and 15 min after switching on)

max. 250 kHz

during warm-up time (after the input stage is in operation for 15 min, measured between 2 s and 15 min after band switching)

max. 250 kHz

at a change of the ambient temperature from + 25 to + 40 °C (measured after 3 cycles from + 25 to + 55 °C)

v.h.f. bands

max. 500 kHz

u.h.f. bands

max. 500 kHz

at a change of humidity from 60 \pm 15% to 93 \pm 2%, at $T_{amb} = 25 \pm 5$ °C

low v.h.f.

max. 500 kHz

high v.h.f.

max. 1500 kHz

u.h.f., channel E21

max. 1500 kHz

u.h.f., channel E69

max. 3000 kHz

Frequency divider characteristics of version UV418

Supply voltage

+ 5 V \pm 5%

Current drawn from + 5 V supply

max. 35 mA; typ. 25 mA

Output voltage, unloaded, at terminals 12 and 13 with 820 Ω load

min. 0,7 V p-p

min. 0,3 V p-p

Output imbalance

typ. 0,1 V

Interference signal on the i.f. output

max. 3 μ V

Note: I.F. output of the tuner terminated with the circuit shown in Fig. 10.

I.F. circuit characteristics

Bandwidth of i.f. output circuit $5,5 \pm 1$ MHz

Note: I.F. output of the tuner terminated with the circuit shown in Fig. 4; tuning voltage 25 V; u.h.f. band switched on.

Bandwidth variation of i.f. output circuit as a result of r.f.

tuning and band switching (reference: u.h.f.; tuning voltage 25 V; a.g.c. voltage 1 V; i.f. output circuit adjusted to 36,15 MHz) max. 500 kHz ←

Note: I.F. output of the tuner terminated with a modified circuit of Fig. 4, i.e. a 100 pF capacitor is connected in parallel with the i.f. output of the tuner.

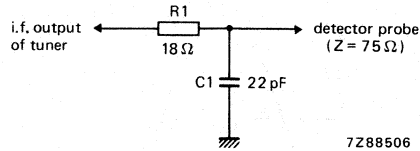

Fig. 4.

Detuning of i.f. output circuit as a result of r.f. tuning and band switching (reference: u.h.f.; tuning voltage 25 V; a.g.c. voltage 1 V; i.f. output circuit adjusted to 36,15 MHz) max. 500 kHz ←

Note: I.F. output of the tuner terminated with a modified circuit of Fig. 4, i.e. a 100 pF capacitor is connected in parallel with the i.f. output of the tuner.

Minimum tuning range of i.f. output coil 33 to 40 MHz

Note: I.F. output of the tuner terminated with the circuit shown in Fig. 4.

Attenuation between i.f. injection point and i.f. output of the tuner

typ. 16 dB

Miscellaneous

Radio interference

Oscillator radiation and oscillator voltage at the aerial terminal

Within the limits of C.I.S.P.R. 13 (1975) and VDE 0872/7.72 and Amtsblatt DBP69/1981, when applying the tuner in an adequate TV receiver.

Microphonics

There will be no microphonics, provided the tuner is installed in a professional manner.

Surge protection

Protection against voltages

max. 5 kV

Note: 10 discharges of a 470 pF capacitor into the aerial terminal.

Protection against flashes

max. 30 kV, 400 mWs

Note: A flashover circuit producing flashes with frequencies of 1 to 20 Hz for 30 s is connected to the aerial terminal.

ADDITIONAL INFORMATION

I.F. injection

An i.f. signal from a generator with an internal resistance of 50Ω or 75Ω should be connected to the i.f. injection point at the top of the tuner (see Fig. 2) via a resistor of 68Ω . The u.h.f. band should be switched on; tuning voltage should be 25 V , a.g.c. voltage 1 V .

Measuring method of power gain

The i.f. output of the tuner should be terminated with the RC-circuit given in Fig. 4.

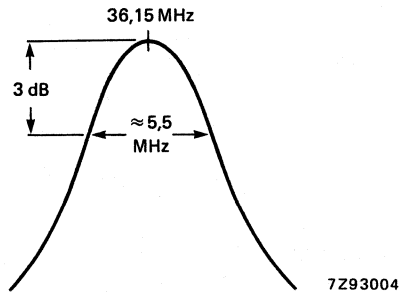

Fig. 5.

The RC-circuit roughly matches the i.f. output impedance to 75Ω at the resonant frequency of the i.f. output circuit, which should be tuned to $36,15 \text{ MHz}$; the bandwidth is approx. $5,5 \text{ MHz}$ (Fig. 5).

Because the input and output impedances of the tuner are now 75Ω , the power gain can be measured in the conventional manner by inserting tuner and RC-circuit between a 75Ω source and a 75Ω detector.

Alignment of the i.f. output coil

The i.f. output coil should be adjusted with a plastic tool which has a cross head as shown in Fig. 6. A suitable tool for automatic alignment is available under catalogue number 8104 004 11040.

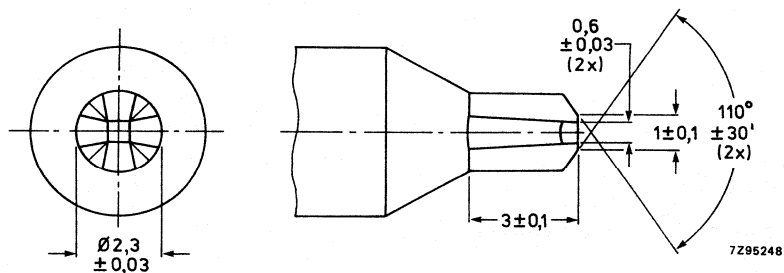

Fig. 6.

V.H.F./U.H.F. TELEVISION TUNER**QUICK REFERENCE DATA**

Systems	C.C.I.R. systems M and N (R.T.M.A.)
Channels	
low v.h.f.	A2 to A6
high v.h.f.	A7 to A13
u.h.f.	A14 to A83
Intermediate frequencies	
picture	45,75 MHz
sound	41,25 MHz

APPLICATION

This tuner is designed to cover the v.h.f. and u.h.f. channels of C.C.I.R. systems M and N (R.T.M.A.). It can be provided with a frequency divider, which makes this tuner suitable for digital tuning systems based on frequency synthesis.

DESCRIPTION

The UV431 is a combined v.h.f./u.h.f. tuner with electronic tuning and band switching, covering the low v.h.f. band (frequency range 55,25 to 83,25 MHz), the high v.h.f. band (frequency range 175,25 to 211,25 MHz), and the u.h.f. band (frequency range 471,25 to 885,25 MHz).

Mechanically, the tuner is built on a low-loss printed-wiring board, carrying all components, in a metal housing made of a rectangular frame and front and rear covers (see Fig. 2). The common phono aerial connector (v.h.f. and u.h.f.) is on one of the frame sides, all other connections (supply voltages, a.g.c. voltage, tuning and switching voltages, i.f. output) are made via terminals in the underside. The mounting method is shown in Fig. 3.

Electrically, the tuner consists of a v.h.f. and a u.h.f. part. The v.h.f. aerial signal is fed via low pass, high pass, i.f. and f.m. suppression filters to a switchable single tuned input circuit for low and high v.h.f. operation, which is capacitively coupled to the gate 1 of a MOS-FET tetrode (with internal gate protection against surge). The drain load of the MOS-FET tetrode is formed by a double tuned, switchable bandpass filter, transferring the r.f. signal to the emitter of the mixer transistor. The oscillator signal is also fed to the emitter of the mixer transistor.

The collector circuit of the mixer transistor is a single tuned i.f. resonant circuit, at the low end of which the i.f. signal is coupled out of the tuner. A test point (terminal 4) is provided for i.f. injection to align the i.f. output circuit of the tuner together with the i.f. amplifier of the television receiver. An additional test point, which is accessible through a hole in the top of the tuner, is connected to the collector of the mixer transistor.

The single tuned input, the r.f. band pass filter and oscillator circuits are tuned by 4 tuning diodes; band switching is achieved by 5 switching diodes.

The u.h.f. part of the tuner consists of a fixed double tuned band pass filter with a built-in protection diode against surge which is connected to gate 1 of an input MOSFET tetrode (with internal gate protection against surge). The drain load of this MOSFET tetrode is formed by a double tuned circuit transferring the r.f. signal to the Schottky barrier mixer diode. The i.f. signal from the mixer diode is amplified by the v.h.f. mixer transistor, now operating as an i.f. amplifier.

The r.f. band pass filter and oscillator circuits are tuned by 3 tuning diodes.

In all bands the tuner is gain controlled via gate 2 of the input MOSFET tetrodes.

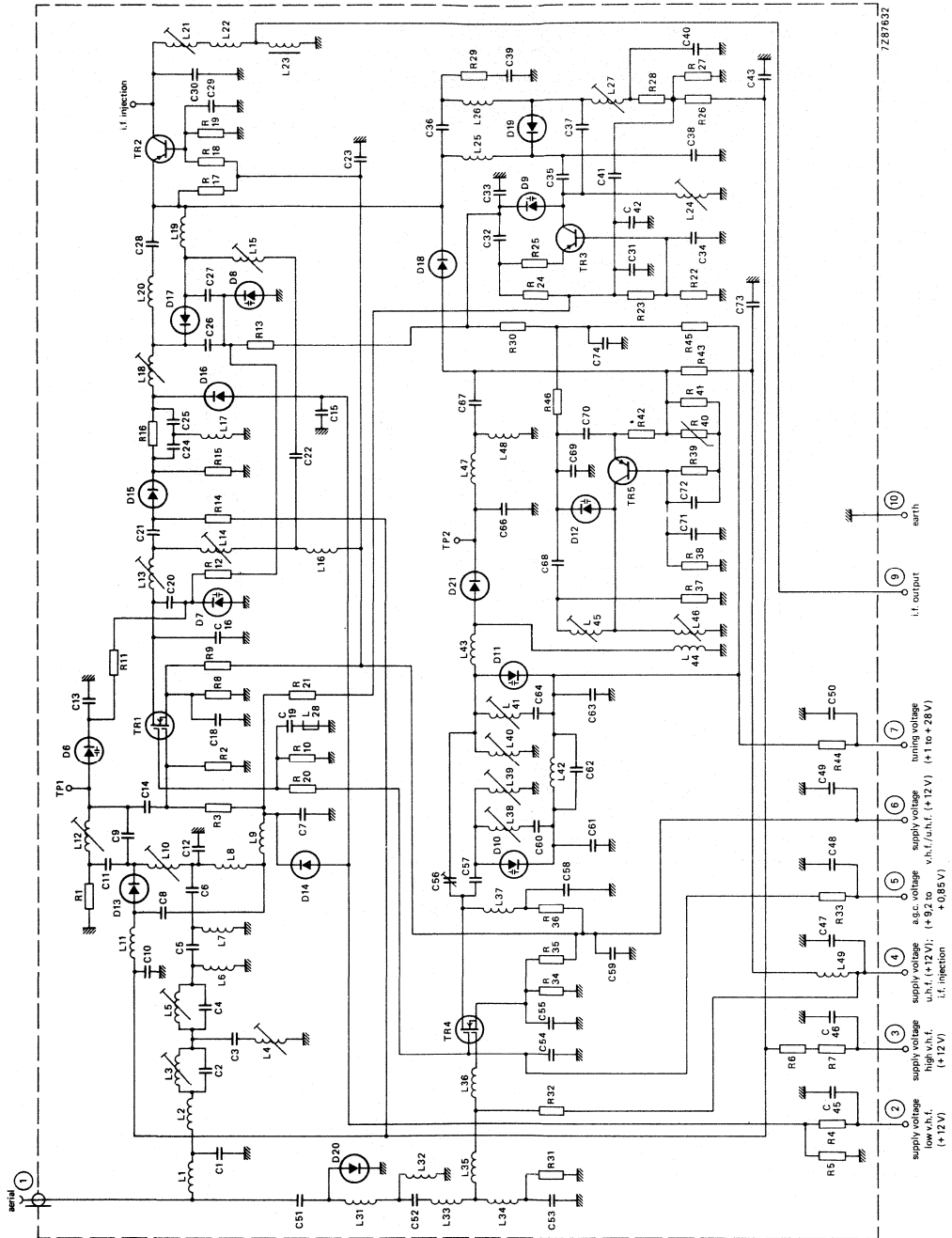
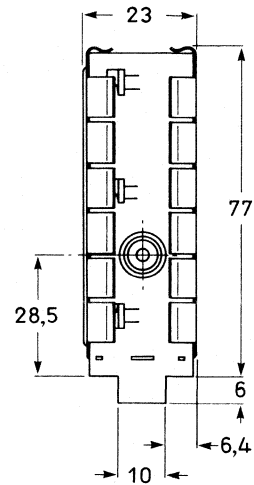
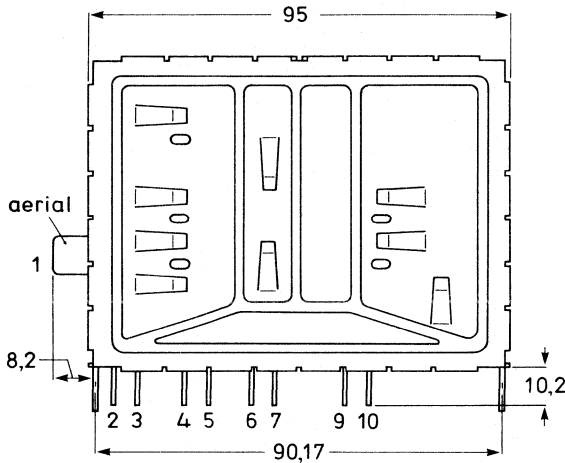
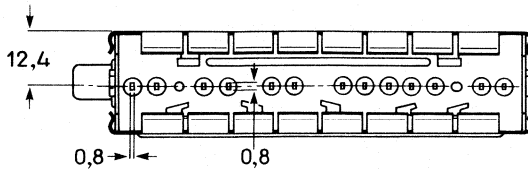

Fig. 1.

MECHANICAL DATA

Dimensions in mm



7290373

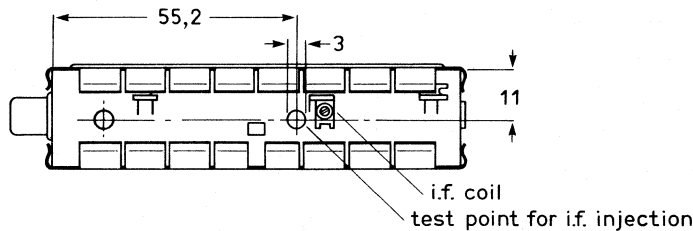

Fig. 2a

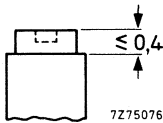

Fig. 2b I.F. output coil.
Torque for alignment: 2 to 15 mNm.
Press-through force: ≥ 10 N.

Terminal

- 1 = aerial
- 2 = supply voltage, low v.h.f., + 12 V
- 3 = supply voltage, high v.h.f., + 12 V
- 4 = supply voltage, u.h.f., + 12 V, i.f. injection
- 5 = a.g.c. voltage, +9,2 to +0,85 V
- 6 = supply voltage, v.h.f. and u.h.f., + 12 V
- 7 = tuning voltage, + 1 to + 28 V
- 9 = i.f. output
- 10 = earth

Mass approx. 125 g.

Mounting

The tuner may be mounted by soldering it on to a printed-wiring board, using the piercing diagram shown in Fig. 3. (The tuner may also be mounted by means of a bracket. Information will be supplied upon request.)

It is recommended that the tuner be installed in the cool part of the receiver cabinet and not exposed to the vibrations of the loudspeaker. There are no restrictions on orientation.

The solderability of the terminals and mounting tabs is according to IEC 68-2, test Ta ($230 \pm 10 \text{ }^\circ\text{C}$, $2 \pm 0,5 \text{ s}$). The resistance to soldering heat is according to IEC 68-2, test Tb ($260 \pm 5 \text{ }^\circ\text{C}$, $10 \pm 1 \text{ s}$).

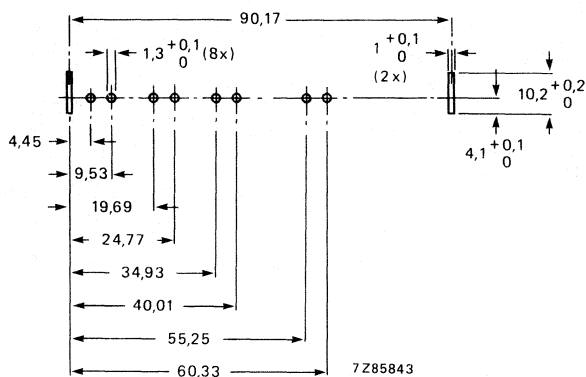

Fig. 3 Piercing diagram viewed from solder side of board.
Unless otherwise stated the tolerance is $\pm 0,05 \text{ mm}$.

Marking

The tuner is provided with a label showing the following data:

- type number UV 431
- catalogue number 3112 127 43630
- code for factory of origin
- change code
- code for year and week of production

ELECTRICAL DATA

Unless otherwise specified all electrical values apply at an ambient temperature of 25 ± 5 °C, a relative humidity of $60 \pm 15\%$, a supply voltage of $12 \pm 0,3$ V and an a.g.c. voltage of $9,2 \pm 0,2$ V.

General**Semiconductors, v.h.f. bands**

r.f. amplifier	BF982
mixer	BF324
oscillator	BF926
tuning diodes	4 x BB809
switching diodes	5 x BA482/483/484
d.c. blocking diodes	2 x BAW62

Semiconductors, u.h.f. bands

r.f. amplifier	BF980
oscillator	BF970
mixer	1SS99
tuning diodes	3 x BB405B
surge protection diodes	BAV10

Ambient temperature range

operating	0 to + 55 °C
storage	-25 to + 70 °C

Relative humidity

max. 95%

Voltages and currents

Supply voltage + 12 V \pm 10%*

Current drawn from + 12 V supply

low and high v.h.f.	max. 55 mA; typ. 42 mA
u.h.f.	max. 50 mA; typ. 42 mA

Bandswitching

For operation in all bands the supply voltage is permanently connected to terminal 6. Additionally the supply voltage is connected to:

- terminal 2 for low v.h.f. operation
- terminal 3 for high v.h.f. operation
- terminal 4 for u.h.f. operation

A.G.C. voltage (Figs 4, 5 and 6)

voltage range	+ 9,2 to + 0,85 V
voltage at nominal gain	+ 9 \pm 0,5 V
voltage at 40 dB gain reduction	
low v.h.f.	typ. 3,2 V
high v.h.f.	typ. 1,5 V
voltage at 30 dB gain reduction	
u.h.f.	typ. 1,4 V

Note: A.G.C. voltages between 0 and + 10,5 V may be applied without risk of damage.

A.G.C. current

max. 0,3 mA

Slope of a.g.c. characteristic,

at the end of the specified a.g.c. range

v.h.f.	typ. 25 dB/V
u.h.f.	typ. 50 dB/V

* A tolerance of -15% on the supply voltage is admissible, if a deterioration of gain, noise figure, oscillator shift and oscillator drift is acceptable.

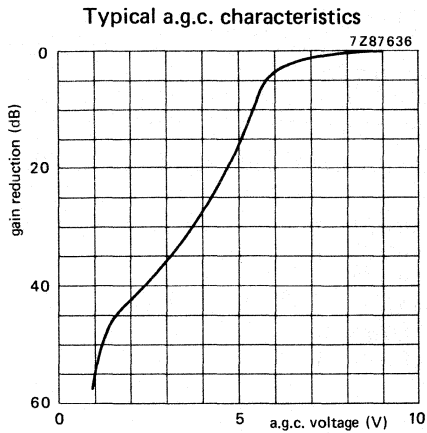

Fig. 4 Low v.h.f.

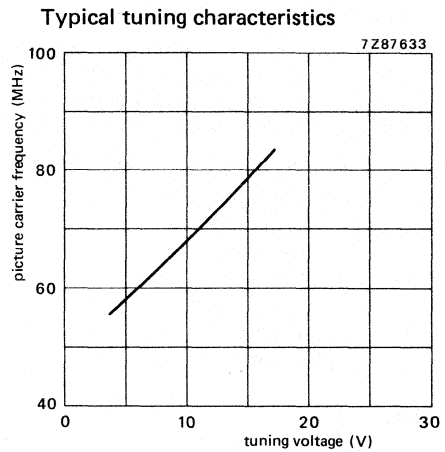

Fig. 7 Low v.h.f.

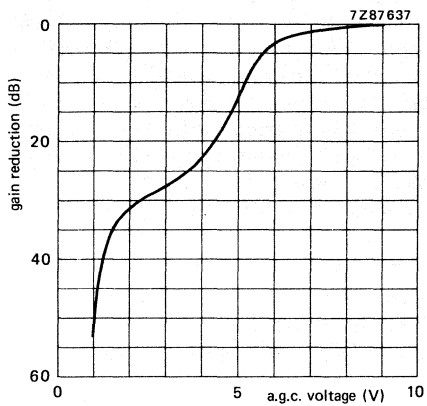

Fig. 5 High v.h.f.

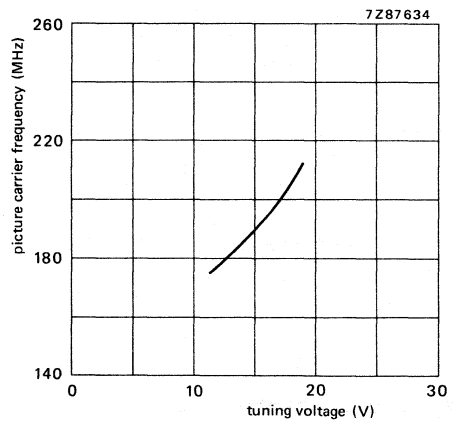

Fig. 8 High v.h.f.

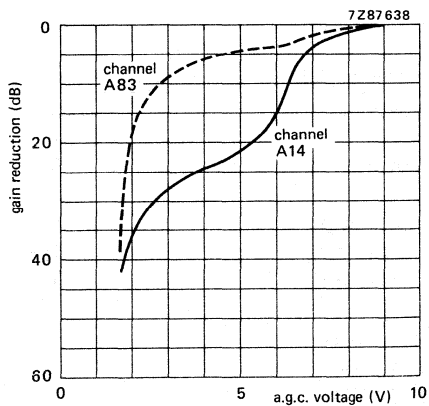

Fig. 6 U.H.F.

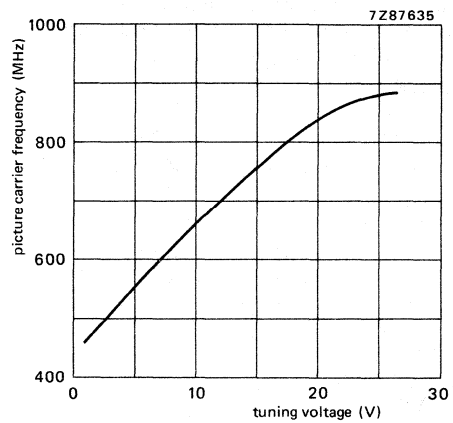

Fig. 9 U.H.F.

Tuning voltage range (Figs 7, 8 and 9) + 1 to + 28 V

Current drawn from 28 V tuning voltage supply
 at $T_{amb} = 25\text{ }^{\circ}\text{C}$ and R.H. = 60% max. $0,5\ \mu\text{A}$
 at $T_{amb} = 55\text{ }^{\circ}\text{C}$ and R.H. = 60% max. $2\ \mu\text{A}$
 at $T_{amb} = 25\text{ }^{\circ}\text{C}$ and R.H. = 95% max. $2\ \mu\text{A}$

Note: The source impedance of the tuning voltage offered to terminal 7 must be maximum 47 k Ω .

Slope of tuning characteristic

low v.h.f., channel A2	3 MHz/V	} typical values
channel A6	2 MHz/V	
high v.h.f., channel A7	6 MHz/V	
channel A13	4 MHz/V	
u.h.f., channel A14	21 MHz/V	
channel A83	4 MHz/V	

Frequencies

Frequency ranges

low v.h.f.	channel A2 (picture carrier 55,25 MHz) to channel A6 (picture carrier 83,25 MHz). * Margin at the extreme channels: min. 1,5 MHz.
high v.h.f.	channel A7 (picture carrier 175,25 MHz) to channel A13 (picture carrier 211,25 MHz). Margin at the extreme channels: min. 2 MHz.
u.h.f.	channel A14 (picture carrier 471,25 MHz) to channel A83 (picture carrier 885,25 MHz). Margin at the extreme channels: A13 min. 3 MHz, A83 min. 4 MHz.

Intermediate frequencies

picture	45,75 MHz
sound	41,25 MHz
	The oscillator frequency is higher than the aerial signal frequency.

Wanted signal characteristics

Input impedance 75 Ω

V.S.W.R. and reflection coefficient (values between picture and sound carrier, as well as values at picture carrier)

v.s.w.r.	at nominal gain	during gain control
v.h.f.	max. 5	max. 5
u.h.f., channels A14 to A73	max. 5	max. 7
channels A74 to A83	max. 5	max. 8
reflection coefficient		
v.h.f.	max. 66%	max. 66%
u.h.f., channels A14 to A73	max. 66%	max. 75%
channels A74 to A83	max. 66%	max. 78%

R.F. curves, bandwidth

low v.h.f.	typ. 10 MHz
high v.h.f.	typ. 12 MHz
u.h.f.	typ. 24 MHz

R.F. curves, tilt	on any channel the amplitude difference between the top of the r.f. resonant curve and the picture frequency, the sound frequency, or any frequency between them will not exceed 3 dB at nominal gain, and 4 dB in the a.g.c. range between nominal gain and 20 dB gain reduction.
A.G.C. range	
v.h.f.	min. 40 dB
u.h.f.	min. 30 dB
Power gain (see also Measuring method of power gain)	
v.h.f. bands	min. 22 dB
channel A4	typ. 26 dB
channel A7	typ. 26 dB
channel A13	typ. 27 dB
u.h.f. bands	min. 20 dB
channel A14	typ. 26 dB
channel A40	typ. 26 dB
channel A83	typ. 24 dB
Maximum gain difference	
between any two v.h.f. channels	typ. 4 dB
between any two u.h.f. channels	typ. 4 dB
between any v.h.f. and u.h.f. channel	typ. 6 dB
Noise figure	
v.h.f. bands, except channel A6	max. 7 dB
channel A6	max. 9 dB
channel A4	typ. 5 dB
channel A7	typ. 5 dB
channel A13	typ. 5 dB
u.h.f. bands	max. 10 dB
channel A14	typ. 5 dB
channel A40	typ. 5,5 dB
channel A83	typ. 7 dB
Overloading	
Input signal producing 1 dB gain compression at nominal gain	
v.h.f.	typ. 90 dB (μ V) into 75 Ω
u.h.f.	typ. 90 dB (μ V) into 75 Ω
Input signal producing either a detuning of the oscillator of + 300 kHz or -1000 kHz or stopping of the oscillations at nominal gain	
v.h.f.	typ. 100 dB (μ V) into 75 Ω
u.h.f.	typ. 100 dB (μ V) into 75 Ω
Unwanted signal characteristics	
Image rejection (measured at picture carrier frequency)	
v.h.f.	min. 60 dB; typ. 70 dB
u.h.f.	min. 40 dB; typ. 50 dB

I.F. rejection (measured at picture carrier frequency)

low v.h.f.	
channel A2	min. 45 dB
channels A3 to A6	min. 50 dB
high v.h.f.	min. 60 dB
u.h.f.	min. 60 dB

Note: At colour sub-carrier frequency maximum 6 dB less rejection.

F.M. rejection, low v.h.f.

Level of an f.m. signal of 91,5 MHz which produces an i.f. signal (47,75 MHz) 57 dB below the level of the wanted picture carrier

channel A2	typ. 100 dB (μ V)
channel A4	typ. 100 dB (μ V)
channel A6	typ. 60 dB (μ V)

F.M. rejection, high v.h.f.

Level of an f.m. signal between 88 and 105 MHz, which produces an i.f. interfering (45,75 MHz) 57 dB below the level of the wanted picture carrier. Level of input picture carrier is 60 dB μ V

channel A8	typ. 95 dB (μ V)
channel A11	typ. 92 dB (μ V)
channel A13	typ. 95 dB (μ V)

Channel A6 colour beat

The colour beat is an interference at 42 MHz from picture and sound carrier signals of channel A6 with the oscillator signal (input levels of picture/sound carrier signals 54 dB(μ V)); tuner operated at nominal gain.

Rejection below IF picture carrier of 45,75 MHz. typ. 45 dB

N \pm 7 rejection (for u.h.f. only)

Interference signal for an interference ratio of 53 dB referred to wanted picture carrier (wanted signal 60 dB (μ V)); tuner operating at nominal gain

typ. 65 dB (μ V) into 75 Ω

Cross modulation

Input signal producing 1% cross modulation, i.e. 1% of the modulation depth of the interfering signal is transferred to the wanted signal.

In channel cross modulation (wanted signal: picture carrier frequency; interfering signal: sound carrier frequency)

v.h.f. bands

at nominal gain (wanted input level 60 dB (μ V)) typ. 76 dB (μ V) into 75 Ω
 at 40 dB gain reduction (wanted input level 100 dB (μ V)) typ. 94 dB (μ V) into 75 Ω

u.h.f. bands

at nominal gain (wanted input level 60 dB (μ V)) typ. 74 dB (μ V) into 75 Ω
 at 30 dB gain reduction (wanted input level 90 dB (μ V)) typ. 88 dB (μ V) into 75 Ω

In band cross modulation (wanted signal: picture carrier of channel N; interfering signal: picture carrier of channel N \pm 2 for low v.h.f., or channel N \pm 3 for high v.h.f., or channel N \pm 5 for u.h.f.)

v.h.f. bands

at nominal gain (wanted input level 60 dB (μ V)) typ. 88 dB (μ V) into 75 Ω
 at 40 dB gain reduction (wanted input level 100 dB (μ V)) typ. 100 dB (μ V) into 75 Ω

u.h.f. bands

at nominal gain (wanted input level 60 dB (μ V)) typ. 82 dB (μ V) into 75 Ω
 at 30 dB gain reduction (wanted input level 90 dB (μ V)) typ. 88 dB (μ V) into 75 Ω

Out of band cross modulation at nominal gain

low v.h.f., interfering from high v.h.f. typ. 100 dB (μ V) into 75 Ω
 low v.h.f., interfering from u.h.f. typ. 100 dB (μ V) into 75 Ω
 high v.h.f., interfering from low v.h.f. typ. 100 dB (μ V) into 75 Ω
 high v.h.f., interfering from u.h.f. typ. 100 dB (μ V) into 75 Ω
 u.h.f. interfering from low v.h.f. typ. 94 dB (μ V) into 75 Ω
 u.h.f. interfering from high v.h.f. typ. 86 dB (μ V) into 75 Ω

Oscillator characteristics**Pulling:**

Input signal of tuned frequency producing a shift of the oscillator frequency of 10 kHz, at nominal gain

low v.h.f. typ. 88 dB (μ V) into 75 Ω
 high v.h.f. typ. 86 dB (μ V) into 75 Ω
 u.h.f. typ. 80 dB (μ V) into 75 Ω

Shift of oscillator frequency at a change of the supply voltage of 5%

v.h.f. bands max. 200 kHz
 u.h.f. bands,
 channels A14 to A73 max. 400 kHz
 channels A74 to A83 max. 800 kHz

Drift of oscillator frequency

during warm-up time (after the tuner has been completely out of operation for 15 min, measured between 5 s and 15 min after switching on)	max. 250 kHz
during warm-up time (after the input stage is in operation for 15 min, measured between 2 s and 15 min after band switching)	max. 250 kHz
at a change of the ambient temperature from + 25 to + 50 °C (measured after 3 cycles from + 25 to + 55 °C)	max. 600 kHz
at a change of humidity from $60 \pm 15\%$ to $93 \pm 2\%$ (measured at $T_{amb} = 25 \pm 5$ °C)	
v.h.f.	max. 600 kHz
u.h.f.	max. 1000 kHz

I.F. circuit characteristics

Bandwidth of i.f. output circuit	5 ± 1 MHz
Note: I.F. output of the tuner terminated with the circuit shown in Fig. 10; tuning voltage 10 V; u.h.f. band switched on.	

Bandwidth variation of i.f. output circuit as a result of r.f. tuning and band switching (reference: u.h.f.; tuning voltage 10 V; i.f. output circuit adjusted to 43,5 MHz)	max. 650 kHz
---	--------------

Note: I.F. output of the tuner terminated with a modified circuit of Fig. 10, i.e. a 100 pF capacitor is connected in parallel with the i.f. output of the tuner.

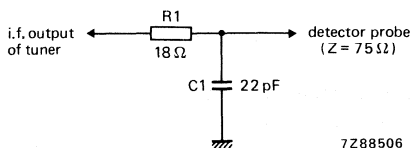

Fig. 10.

Detuning of the i.f. output circuit as a result of r.f. tuning and band switching (reference: u.h.f.; tuning voltage 10 V; i.f. output circuit adjusted to 43,5 MHz)	max. 650 kHz
--	--------------

Note: I.F. output of the tuner terminated with a modified circuit of Fig. 10, i.e. a 100 pF capacitor is connected in parallel with the i.f. output of the tuner.

Minimum tuning range of i.f. output coil	41 to 47 MHz
--	--------------

Note: I.F. output of the tuner terminated with the circuit shown in Fig. 10. The tuner is supplied with the i.f. output circuit adjusted to $43,5 \pm 1$ MHz.

Attenuation between i.f. injection point and i.f. output of the tuner	typ. 16 dB
---	------------

Miscellaneous

Radio interference
Oscillator radiation and oscillator
voltage at the aerial terminal

Within the limits of C.I.S.P.R. 13
(1975)

Microphonics

There will be no microphonics,
provided the tuner is installed
in a professional manner.

Surge protection
Protection against voltages

max. 5 kV

Note: 10 discharges of a 470 pF capacitor into the aerial terminal.

Protection against flashes

max. 30 kV, 400 mWs

Note: A flashover circuit producing flashes with frequencies of 1 to 20 Hz for 30 s is connected to the aerial terminal.

ADDITIONAL INFORMATION

I.F. injection

Terminal 4 (supply voltage u.h.f.) can be used as i.f. injection point, provided the u.h.f. supply voltage is applied to terminal 4 via a resistor of 10 Ω (see Fig. 11). The u.h.f. band should be switched on; tuning voltage should be 2 V.

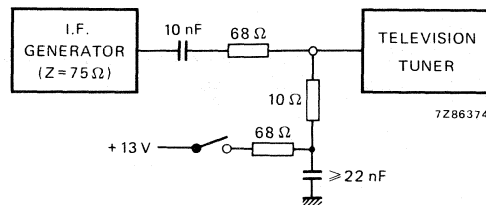

Fig. 11.

Connection of the i.f. amplifier

- By means of a print track as short as possible.
- By means of a shielded track, e.g. a coaxial cable.

Connection of supply voltages

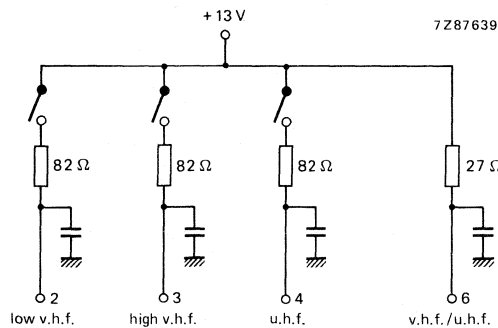

Fig. 12.

Measuring method of power gain

The i.f. output of the tuner should be terminated with the RC-circuit given in Fig. 10.

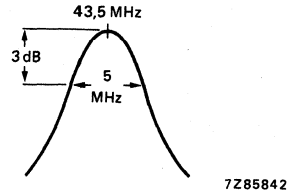

Fig. 13.

The RC-circuit roughly matches the i.f. output impedance to 75Ω at the resonant frequency of the i.f. output circuit which should be tuned to 43,5 MHz; the bandwidth is approx. 5 MHz (Fig. 13).

Because the input and output impedances of the tuner are now 75Ω , the power gain can be measured in the conventional manner by inserting tuner and RC-circuit between a 75Ω source and a 75Ω detector.

Measurement of bandwidth variation and detuning of i.f. output circuit

A sweep signal of 30 to 50 MHz from a frequency sweep generator is connected to the i.f. injection point via a capacitor of 0,5 pF. The coaxial cable is terminated with 75Ω .

Alignment of the i.f. output coil

The i.f. output coil should be adjusted with a brass tool with a blade as shown in Fig. 14. A suitable tool is available under catalogue number 7122 005 47680.

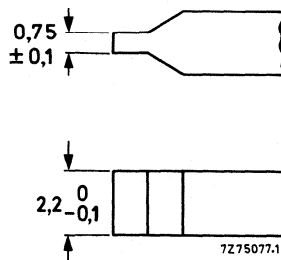

Fig. 14.

TESTS AND REQUIREMENTS

IEC 68-2	test	procedure	requirements
Ab	cold	-25 °C, 96 h	Checked within 10 min after all tests mentioned: no catastrophic failures (in operation of 1 or more channels).
Bb	dry heat	+ 70 °C, 96 h	
Db	damp heat, cyclic	+ 25 to + 40 °C R.H. 90 to 100% 21 cycles of 24 h	
Ca	damp heat, steady state	+ 40 °C, R.H. 93% 21 days	After 1 h reconditioning under normal conditions: change of osc. freq. low v.h.f. $\leq 1,5$ MHz high v.h.f. ≤ 2 MHz change of power gain ≤ 2 dB change of tilt r.f. curve ≤ 2 dB change of tuning current $\leq 0,5 \mu\text{A}$
Na	rapid change of temperature	3h -25 °C/3h + 70 °C 5 cycles	
Fc	vibration	10-55-10 Hz, amplitude 0,35 mm 3 directions 30 min per direction	
Eb	bump	1000 bumps, acceleration 25g, in 6 directions	
Ea	shock	half sine pulse 11 ms, acceleration 50g in 6 directions 3 times per direction	

V.H.F./U.H.F. TELEVISION TUNERS

QUICK REFERENCE DATA

Systems	C.C.I.R. systems B and G
Channels *	
low v.h.f. band	0 to 4
high v.h.f. band	5 to 11
u.h.f. bands	28 to 63
Intermediate frequencies	
picture	38,875 MHz
sound	31,375 MHz

APPLICATION

Designed to cover the Australian v.h.f. and u.h.f. channels of C.C.I.R. systems B and G.

The tuners UV462 are equipped with a frequency divider, which makes them suitable for digital tuning systems based on frequency synthesis; for the remainder they are equal to type UV461.

Available versions

	aerial input connector	frequency divider (IC)	division ratio	catalogue number
UV461	phono	—	—	3122 127 48460
UV461/IEC	IEC	—	—	3122 237 00020
UV462/256	phono	8-pin	256	3122 237 00030
UV462/256/IEC	IEC	8-pin	256	3122 237 00040

* In accordance with the publications of the Australian Broadcasting Control Board (A.B.C.B.).

DESCRIPTION

The UV461 and UV462 are combined v.h.f./u.h.f. tuners with electronic tuning and band switching, covering the low v.h.f. band including the New Zealand channel 1, and the Italian channel C (frequency range 44 to 92 MHz), the high v.h.f. band including the Morocco channel M4 (frequency range 162 to 230 MHz), and the u.h.f. band (frequency range 470 to 861 MHz).

Mechanically, the tuner is built on a low-loss printed-wiring board, carrying all components, in a metal housing made of a rectangular frame and front and rear covers (see Fig. 2). The common 75 Ω phono or IEC aerial connector (v.h.f. and u.h.f.) is on one of the frame sides, all other connections (supply voltages, a.g.c. voltage, tuning and switching voltages, i.f. output) are made via terminals in the underside. The mounting method is shown in Fig. 3.

Electrically, the tuner consists of v.h.f. and u.h.f. parts. The v.h.f. aerial signal is fed via switchable low and high v.h.f. wide band input filters to gate 1 of an input MOSFET tetrode (with internal gate protection against surge).

The input filters are provided with an i.f. suppression circuit. The drain load of the MOSFET tetrode is formed by a double tuned switchable bandpass filter, transferring the r.f. signal to the emitter of the mixer transistor. The oscillator signal is also fed to the emitter of the mixer transistor.

The collector circuit of the mixer transistor is a single tuned i.f. resonant circuit, at the low end of which the i.f. signal is coupled out of the tuner. A test point (terminal 4) is provided for i.f. injection to align the i.f. output circuit of the tuner together with the i.f. amplifier of the television receiver. An additional test point, which is accessible through a hole in the top of the tuner, is connected to the collector of the mixer transistor.

The r.f. band pass filter and oscillator circuits are tuned by 5 tuning diodes; band switching is achieved by 5 switching diodes.

The u.h.f. part of the tuner consists of a high-pass input circuit connected to gate 1 of an input MOSFET tetrode (with internal gate protection against surge). The drain load of this MOSFET tetrode is formed by a double tuned circuit transferring the r.f. signal to the Schottky barrier mixer diode. The i.f. signal from the mixer diode is amplified by the v.h.f. mixer transistor, now operating as an i.f. amplifier.

The r.f. band pass filter and oscillator circuits are tuned by 3 tuning diodes.

In all bands the tuner is gain controlled via gate 2 of the input MOSFET tetrodes.

The electrical circuit of the UV462 is extended with a frequency divider (division ratio of 256), which inputs are connected to the v.h.f. and u.h.f. oscillator. The complementary outputs are connected to terminals 12 and 13.

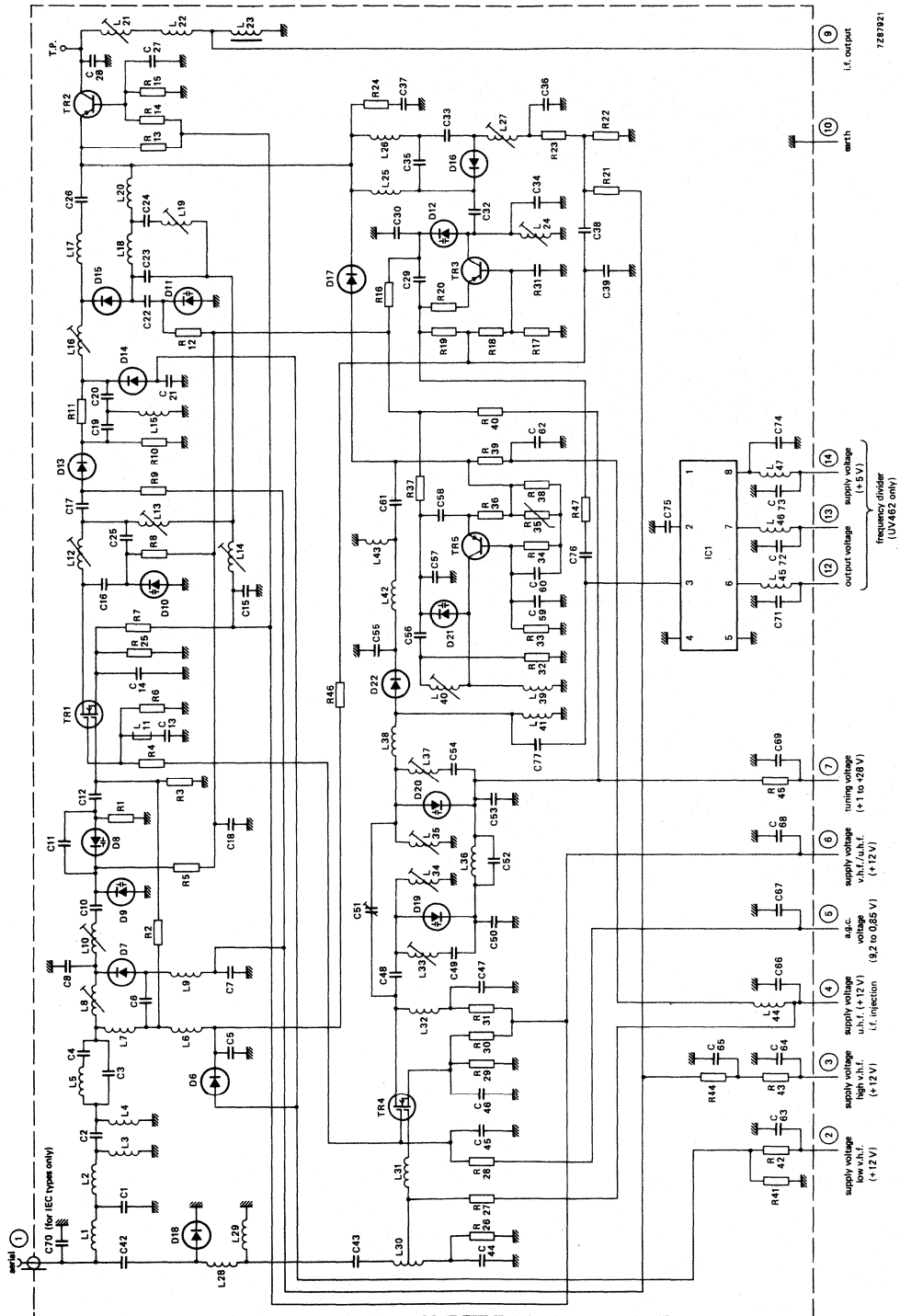
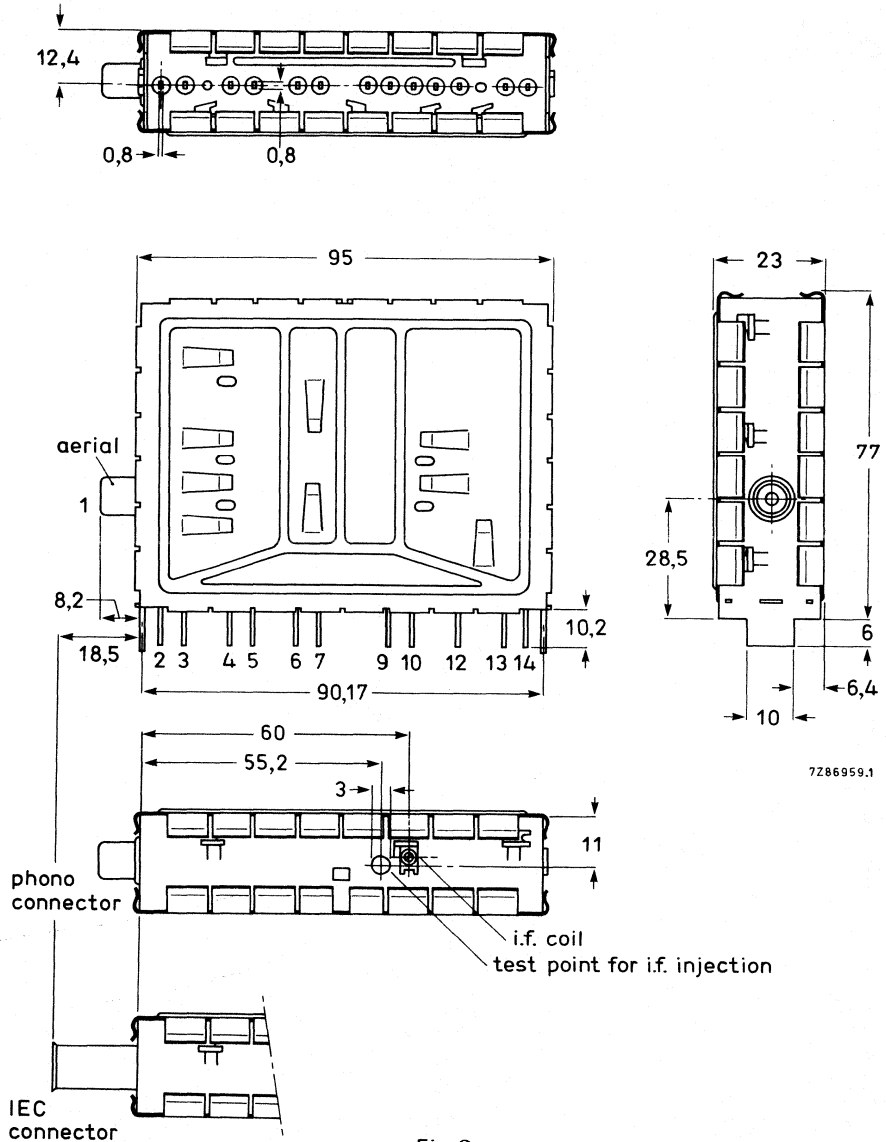

Fig. 1.

MECHANICAL DATA

Dimensions in mm



7286959.1

Fig. 2a.

Terminal

- | | | |
|--|---|------------------|
| 1 = aerial | 7 = tuning voltage, + 1 to + 28 V | } only for UV462 |
| 2 = supply voltage, low v.h.f., + 12 V | 9 = i.f. output | |
| 3 = supply voltage, high v.h.f., + 12 V | 10 = earth | |
| 4 = supply voltage, u.h.f., + 12 V; i.f. injection | 12, 13 = balanced output voltage of frequency divider | |
| 5 = a.g.c. voltage, + 9,2 to 0,85 V | 14 = supply voltage, frequency divider, + 5 V | |
| 6 = supply voltage, v.h.f. and u.h.f., + 12 V | | |

Fig. 2b I.F. output coil.
Torque for alignment: 2 to 15 mNm.
Press-through force: ≥ 10 N.

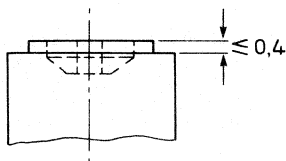

Mass approx. 127 g

Mounting

The tuner may be mounted by soldering it on to a printed-wiring board, using the piercing diagram shown in Fig. 3. (The tuner may also be mounted by means of a bracket. Information will be supplied upon request). The tuner may be mounted anywhere in the receiver and there are no restrictions on orientation.

The solderability of the terminals and mounting tabs is according to IEC 68-2, test Ta (230 ± 10 °C, $2 \pm 0,5$ s). The resistance to soldering heat is according to IEC 68-2, test Tb (260 ± 5 °C, 10 ± 1 s).

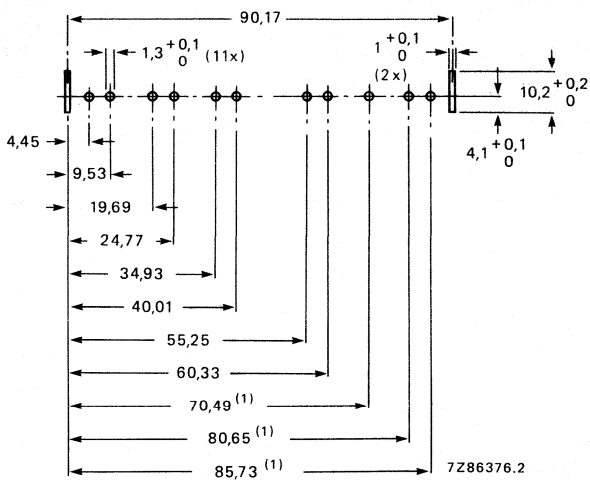

(1) Only for UV462.

Fig. 3 Piercing diagram viewed from solder side of board.
Unless otherwise stated the tolerance is $\pm 0,05$ mm.

ELECTRICAL DATA

Unless otherwise specified all electrical values apply at an ambient temperature of 25 ± 5 °C, a relative humidity of $60 \pm 15\%$, a supply voltage of $12 \pm 0,3$ V and an a.g.c. voltage of $9,2 \pm 0,2$ V.

General

Semiconductors, v.h.f. bands

r.f. amplifier	BF980
mixer	BF324
oscillator	BF926
tuning diodes	5 x BB909B
switching diodes	5 x BA482/483/484
d.c. blocking diodes	2 x IN4148

Semiconductors, u.h.f. bands

r.f. amplifier	BF980
oscillator	BF970
mixer	1SS99
tuning diodes	3 x OF643
surge protection diodes	1 x BAV10
frequency divider	SP4653

Ambient temperature range

operating	0 to + 55 °C
storage	-25 to + 70 °C

Relative humidity

max. 95%

Voltages and currents

Supply voltage

+ 12 V \pm 10%

Current drawn from + 12 V supply

v.h.f. bands	max. 55 mA; typ. 39 mA
u.h.f. bands	max. 50 mA; typ. 40 mA

Bandswitching

For operation in all bands the supply voltage is permanently connected to terminal 6. Additionally the supply voltage is connected to:

- terminal 2 for operation in the low v.h.f. band
- terminal 3 for operation in the high v.h.f. band
- terminal 4 for operation in the u.h.f. bands

A.G.C. voltage (Figs 4, 5 and 6)

voltage range	+ 9,2 to + 0,85 V
voltage at nominal gain	+ 9,2 \pm 0,5 V
voltage at 40 dB gain reduction	
low v.h.f. band	typ. 3 V
high v.h.f. band	typ. 2 V
voltage at 30 dB gain reduction, u.h.f. bands	typ. 1,6 V

Note: A.G.C. voltages between 0 and + 10,5 V may be applied without risk of damage.

A.G.C. current

max. 0,3 mA

Slope of a.g.c. characteristic,

at the end of the specified a.g.c. range

v.h.f. bands	typ. 25 dB/V
u.h.f. bands	typ. 50 dB/V

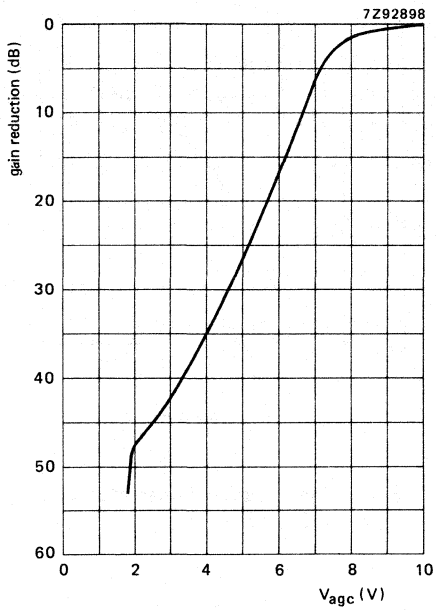

Fig. 4 Typical a.g.c. characteristic, low v.h.f. band.

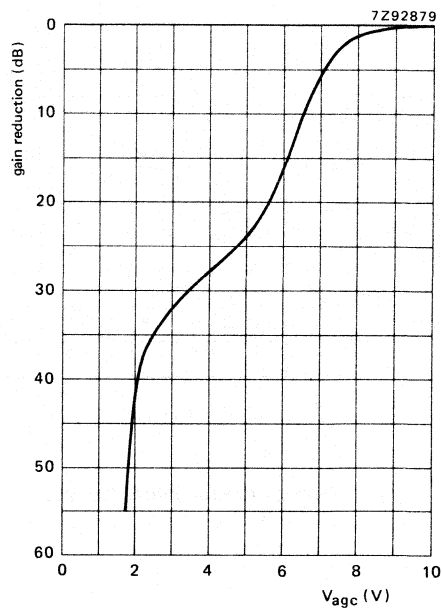

Fig. 5 Typical a.g.c. characteristic, high v.h.f. band.

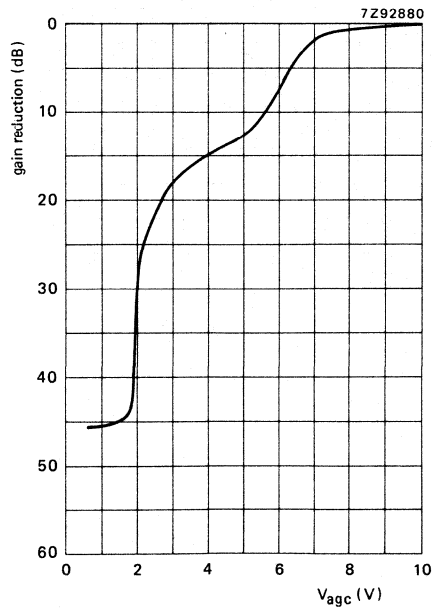

Fig. 6 Typical a.g.c. characteristic, u.h.f. bands.

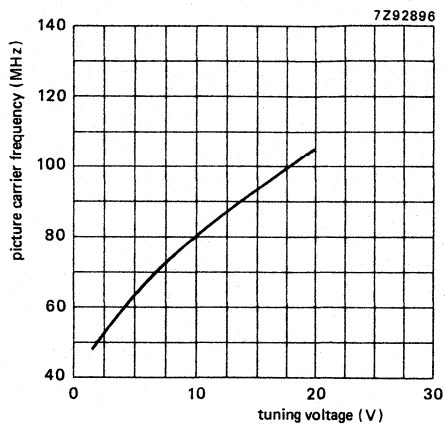

Fig. 7 Typical tuning characteristic, low v.h.f. band.

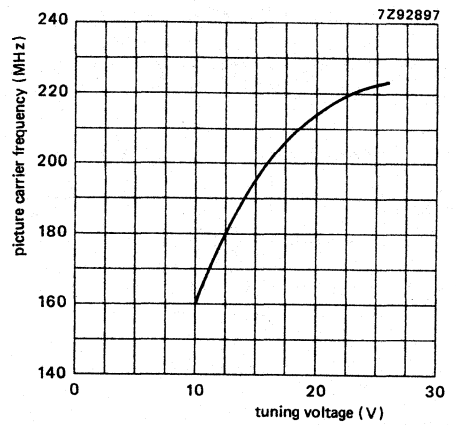

Fig. 8 Typical tuning characteristic, high v.h.f. band.

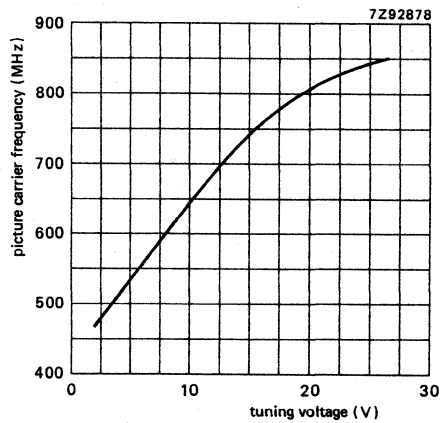

Fig. 9 Typical tuning characteristic, u.h.f. bands.

Tuning voltage range (Figs 7, 8 and 9)	+ 1 to + 28 V
Current drawn from 28 V tuning voltage supply	
at $T_{amb} = 25\text{ }^{\circ}\text{C}$	max. 0,5 μA
at $T_{amb} = 55\text{ }^{\circ}\text{C}$	max. 2 μA

Note: The source impedance of the tuning voltage offered to terminal 7 must be maximum 47 k Ω .

Slope of tuning characteristic		
low v.h.f. band, channel 0	5 MHz/V	} typical values
channel 2	4 MHz/V	
high v.h.f. band, channel 5A	8 MHz/V	
channel 11	3 MHz/V	
u.h.f. bands, channel 28	19 MHz/V	
channel 63	10 MHz/V	

Frequencies

Frequency ranges	
low v.h.f. band	channel 0 (picture carrier 46,25 MHz) to channel 5 (picture carrier 102,25 MHz). Margin at the extreme channels: min. 1,5 MHz.
high v.h.f. band	channel 5A (picture carrier 138,25 MHz) to channel 12 (picture carrier 224,25 MHz). Margin at the extreme channels: min. 2 MHz.
u.h.f. bands	channel 21 (picture carrier 471,25 MHz) to channel 69 (picture carrier 855,25 MHz). Margin at the extreme channels: min. 3 MHz.

Intermediate frequencies

picture	36,875 MHz
sound	31,375 MHz
	The oscillator frequency is higher than the aerial signal frequency.

Wanted signal characteristics

Input impedance	75 Ω	
V.S.W.R. and reflection coefficient (values between picture and sound carrier, as well as values at picture carrier)		
v.s.w.r.	<u>at nominal gain</u>	<u>during gain control</u>
v.h.f. bands	max. 4	max. 5
u.h.f. bands	max. 5	max. 7
reflection coefficient		
v.h.f. bands	max. 60%	max. 66%
u.h.f. bands	max. 66%	max. 75%
R.F. curves, bandwidth		
low v.h.f. band	typ. 10 MHz	
high v.h.f. band	typ. 12 MHz	
u.h.f. bands	typ. 17 MHz	

R.F. curves, tilt

on any channel the amplitude difference between the top of the r.f. resonant curve and the picture frequency, the sound frequency, or any frequency between them will not exceed 3 dB at nominal gain, and 4 dB in the a.g.c. range between nominal gain and 20 dB gain reduction.

A.G.C. range

v.h.f. bands

min. 40 dB

u.h.f. bands

min. 30 dB

Power gain (see also Measuring method of power gain)

v.h.f. bands

min. 22 dB

channel 0

typ. 27 dB

channel 5

typ. 28 dB

channel 5A

typ. 27 dB

channel 11

typ. 29 dB

u.h.f. bands

min. 20 dB

channel 28

typ. 28 dB

channel 40

typ. 28 dB

channel 63

typ. 26 dB

Maximum gain difference

between any two v.h.f. channels

typ. 3 dB

between any two u.h.f. channels

typ. 3 dB

between any v.h.f. and u.h.f. channel

typ. 4 dB

Noise figure

v.h.f. bands

max. 8 dB

channel 0

typ. 5 dB

channel 5

typ. 4 dB

channel 5A

typ. 5,5 dB

channel 11

typ. 5,5 dB

u.h.f. bands

max. 10 dB

channel 28

typ. 6 dB

channel 40

typ. 6 dB

channel 63

typ. 7 dB

Overloading

Input signal producing 1 dB gain

compression at nominal gain

v.h.f. bands

typ. 90 dB (μ V) into 75 Ω

u.h.f. bands

typ. 90 dB (μ V) into 75 Ω

Input signal producing either a detuning

of the oscillator of + 300 kHz or

- 1000 kHz or stopping of the

oscillations at nominal gain

v.h.f. bands

typ. 100 dB (μ V) into 75 Ω

u.h.f. bands

typ. 100 dB (μ V) into 75 Ω

Unwanted signal characteristics

Image rejection (measured at picture carrier frequency)

v.h.f. bands	min. 60 dB; typ. 70 dB
u.h.f. bands, channels 21 to 27	min. 40 dB; typ. 46 dB
channels 28 to 62	min. 44 dB; typ. 53 dB
channels 63 to 69	min. 40 dB; typ. 46 dB

I.F. rejection (measured at picture carrier frequency)

v.h.f. bands	min. 60 dB
u.h.f. bands	min. 60 dB

Note: At colour sub-carrier frequency maximum 6 dB less rejection.

 $N \pm 4$ rejection (for u.h.f. only)

Interference signal for an interference ratio of 47 dB referred to wanted picture carrier (picture to sound carrier ratio of 10 dB; wanted signal 60 dB (μV); tuner operating at nominal gain)

typ. 70 dB (μV) into 75 Ω **Cross modulation**

Input signal producing 1% cross modulation, i.e. 1% of the modulation depth of the interfering signal is transferred to the wanted signal.

In channel cross modulation (wanted signal: picture carrier frequency; interfering signal: sound carrier frequency)

v.h.f. bands	
at nominal gain (wanted input level 60 dB (μV))	typ. 74 dB (μV) into 75 Ω
at 40 dB gain reduction (wanted input level 60 dB (μV))	typ. 94 dB (μV) into 75 Ω
u.h.f. bands	
at nominal gain (wanted input level 60 dB (μV))	typ. 74 dB (μV) into 75 Ω
at 30 dB gain reduction (wanted input level 90 dB (μV))	typ. 94 dB (μV) into 75 Ω

In band cross modulation (wanted signal: picture carrier of channel N; interfering signal: picture carrier of channel $N \pm 2$ for low v.h.f., or channel $N \pm 3$ for high v.h.f., or channel $N \pm 5$ for u.h.f.)

v.h.f. bands	
at nominal gain (wanted input level 60 dB (μV))	typ. 82 dB (μV) into 75 Ω
at 40 dB gain reduction (wanted input level 100 dB (μV))	typ. 94 dB (μV) into 75 Ω
u.h.f. bands	
at nominal gain (wanted input level 60 dB (μV))	typ. 82 dB (μV) into 75 Ω
at 30 dB gain reduction (wanted input level 90 dB (μV))	typ. 94 dB (μV) into 75 Ω

Out of band cross modulation at nominal gain

low v.h.f., interfering from high v.h.f.	typ. 94 dB (μV) into 75 Ω
low v.h.f., interfering from u.h.f.	typ. 90 dB (μV) into 75 Ω
high v.h.f., interfering from low v.h.f.	typ. 94 dB (μV) into 75 Ω
high v.h.f., interfering from u.h.f.	typ. 90 dB (μV) into 75 Ω
u.h.f., interfering from low v.h.f.	typ. 94 dB (μV) into 75 Ω
u.h.f., interfering from high v.h.f.	typ. 86 dB (μV) into 75 Ω

Oscillator characteristics

Pulling

Input signal of tuned frequency producing a shift of the oscillator frequency of 10 kHz, at nominal gain

v.h.f. bands	typ. 80 dB (μ V) into 75 Ω
u.h.f. bands	typ. 80 dB (μ V) into 75 Ω

Shift of oscillator frequency at a change of the supply voltage of 5%

v.h.f. bands	max. 200 kHz
u.h.f. bands	max. 400 kHz

Drift of oscillator frequency

during warm-up time (after the tuner has been completely out of operation for 15 min. measured between 5 s and 15 min after switching on)

max. 250 kHz

during warm-up time (after the input stage is in operation for 15 min, measured between 2 s and 15 min after band switching)

max. 250 kHz

at a change of the ambient temperature from + 25 to + 50 °C (measured after 3 cycles from + 25 to + 55 °C)

v.h.f. bands	max. 600 kHz
u.h.f. bands	max. 1000 kHz

Frequency divider characteristics (UV462)

Supply voltage	+ 5 V \pm 10%
Current drawn from + 5 V supply	max. 35 mA; typ. 25 mA
Output voltage, at terminals 12 and 13 unloaded	min. 0,8 V p-p
with 820 Ω load	min. 0,7 V p-p
Output impedance	min. 0,3 V p-p
Output imbalance	typ. 1 k Ω
Interference signal on the i.f. output	typ. 0,1 V
	max. 3 μ V

Note: I.F. output of the tuner terminated with the circuit shown in Fig. 10.

I.F. circuit characteristics

Bandwidth of i.f. output circuit 5 ± 1 MHz

Note: I.F. output of the tuner terminated with the circuit shown in Fig. 10; tuning voltage 18 V; u.h.f. band switched on.

Bandwidth variation of i.f. output circuit as a result of r.f. tuning and band switching (reference: u.h.f.; tuning voltage 18 V) max. 500 kHz

Note: I.F. output of the tuner terminated with a modified circuit of Fig. 10, i.e. a 100 pF capacitor is connected in parallel with the i.f. output of the tuner.

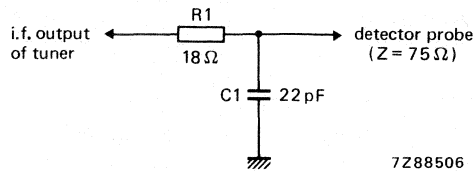

Fig. 10.

Detuning of the i.f. output circuit as a result of r.f. tuning and band switching (reference: u.h.f.; tuning voltage 18 V) max. 500 kHz

Note: I.F. output of the tuner terminated with a modified circuit of Fig. 10, i.e. a 100 pF capacitor is connected in parallel with the i.f. output of the tuner.

Minimum tuning range of i.f. output coil $\leq 31,5$ to $\geq 37,5$ MHz

Note: I.F. output of the tuner terminated with the circuit shown in Fig. 10.

Attenuation between i.f. injection point and i.f. output of the tuner typ. 16 dB

Miscellaneous**Radio interference**

Oscillator radiation and oscillator voltage at the aerial terminal

In conformity with the oscillator interference limits of the Australian Standard AS1053-1973 and the limits of C.I.S.P.R. 13 (1975).

Microphonics

There will be no microphonics, provided the tuner is installed in a professional manner.

Surge protection

Protection against voltages

max. 5 kV

Note: 10 discharges of a 470 pF capacitor into the aerial terminal.

Protection against flashes

max. 30 kV, 400 mWs

Note: A flashover circuit producing flashes with frequencies of 1 to 20 Hz for 30 s is connected to the aerial terminal.

ADDITIONAL INFORMATION

I.F. injection

Terminal 4 (supply voltage u.h.f.) can be used as i.f. injection point, provided the u.h.f. supply voltage is applied to terminal 4 via a resistor of $10\ \Omega$ (see Fig. 11). The u.h.f. band should be switched on; tuning voltage should be $18\ \text{V}$.

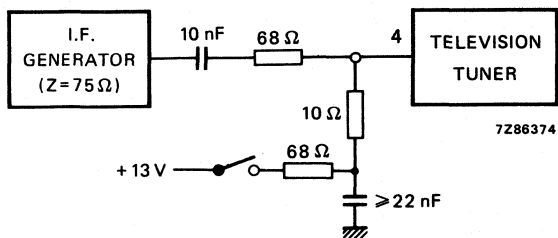

Fig. 11.

Connection of the i.f. amplifier

No special precautions are required to load and to match the i.f. output of the tuner.

Connection of supply voltages

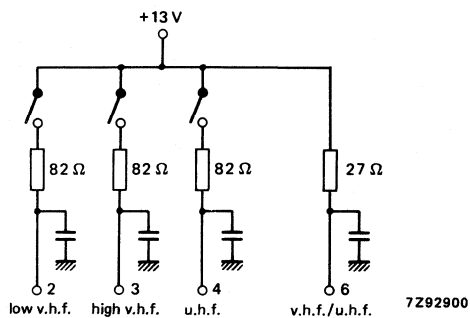

Fig. 12.

Measuring method of power gain

The i.f. output of the tuner should be terminated with the RC-circuit given in Fig. 10.

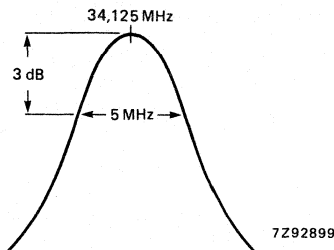

Fig. 13.

The RC-circuit roughly matches the i.f. output impedance to 75Ω at the resonant frequency of the i.f. output circuit, which should be tuned to $36,15 \text{ MHz}$; the bandwidth is approx. 5 MHz (Fig. 13).

Because the input and output impedances of the tuner are now 75Ω , the power gain can be measured in the conventional manner by inserting tuner and RC-circuit between a 75Ω source and a 75Ω detector.

Alignment of the i.f. output coil

The i.f. output coil should be adjusted with a plastic tool, which has a crosshead as shown in Fig. 14. A suitable tool for automatic alignment is available under catalogue number 8104 004 11040.

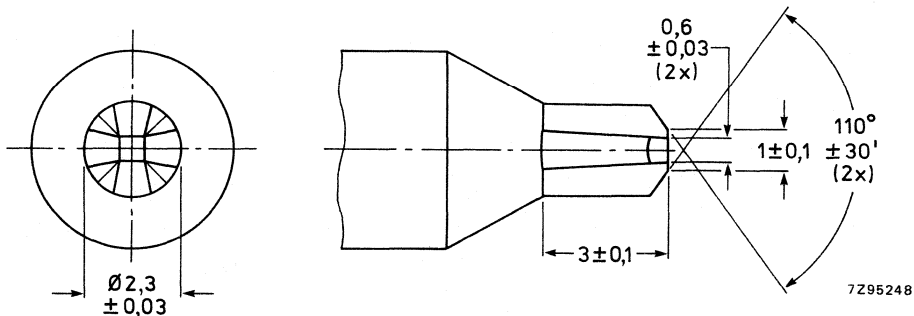

Fig. 14.

V.H.F./U.H.F. TELEVISION TUNERS

QUICK REFERENCE DATA

Systems	C.C.I.R. system
Channels (South African channel distribution)	
v.h.f.	4 to 13
u.h.f.	21 to 69
Intermediate frequencies	
picture	38,9 MHz
sound	32,9 MHz

APPLICATION

Designed to cover the South African v.h.f. and u.h.f. channels of C.C.I.R. system I.
The tuners UV472 are equipped with a frequency divider, which makes them suitable for digital tuning systems based on frequency synthesis; for the remainder they are equal to type UV471.

Available versions

	aerial input connector	frequency divider (IC)	catalogue number
UV471	phono	—	3122 127 03310
UV472/256	phono	1:256	3122 237 00340 ←
UV472/64	phono	1:64	3122 237 00360

DESCRIPTION

The UV471 and UV472 are combined v.h.f./u.h.f. tuners with electronic tuning and band switching, covering the television bands used in South Africa in accordance with the publications of the South African Bureau of Standards (S.A.B.S.).

Mechanically, the tuners are built on a low-loss printed-wiring board, carrying all components, in a metal housing made of a rectangular frame and front and rear covers (see Fig. 2). The common 75 Ω aerial connector (v.h.f. and u.h.f.) is on one of the frame sides, all other connections (supply voltages, a.g.c. voltage, tuning and switching voltages, i.f. output) are made via terminals in the underside. The mounting method is shown in Fig. 3.

Electrically, the tuners consist of v.h.f. and u.h.f. parts. The v.h.f. aerial signal is fed via a tuned input circuit to gate 1 of an input MOSFET tetrode (with internal gate protection against surge).

The drain load of the MOSFET tetrode is formed by a double tuned filter, transferring the r.f. signal to the emitter of the mixer transistor.

The collector circuit of the mixer transistor is a single tuned i.f. resonant circuit, at the low end of which the i.f. signal is coupled out of the tuner. A test point (terminal 4) is provided for i.f. injection to align the i.f. output circuit of the tuner together with the i.f. amplifier of the television receiver.

An additional test point (T.P.), which is accessible through a hole in the top of the tuner, is connected to the collector of the mixer transistor.

The r.f. band pass filter and oscillator circuits are tuned by 4 tuning diodes.

The u.h.f. part of the tuners consist of a high-pass input circuit connected to gate 1 of an input MOSFET tetrode (with internal gate protection against surge). The drain load of this MOSFET tetrode is formed by a double tuned circuit transferring the r.f. signal to the Schottky barrier mixer diode.

The i.f. signal from the mixer diode is amplified by the v.h.f. mixer transistor, now operating as an i.f. amplifier.

The r.f. band pass filter and oscillator circuits are tuned by 3 tuning diodes.

In all bands the tuners are gain controlled via gate 2 of the input MOSFET tetrode.

- The electrical circuit of the UV472 is extended with a frequency divider (division ratio of 256 or 64), which inputs are connected to the v.h.f. and u.h.f. oscillator. The complementary outputs are connected to terminals 12 and 13.

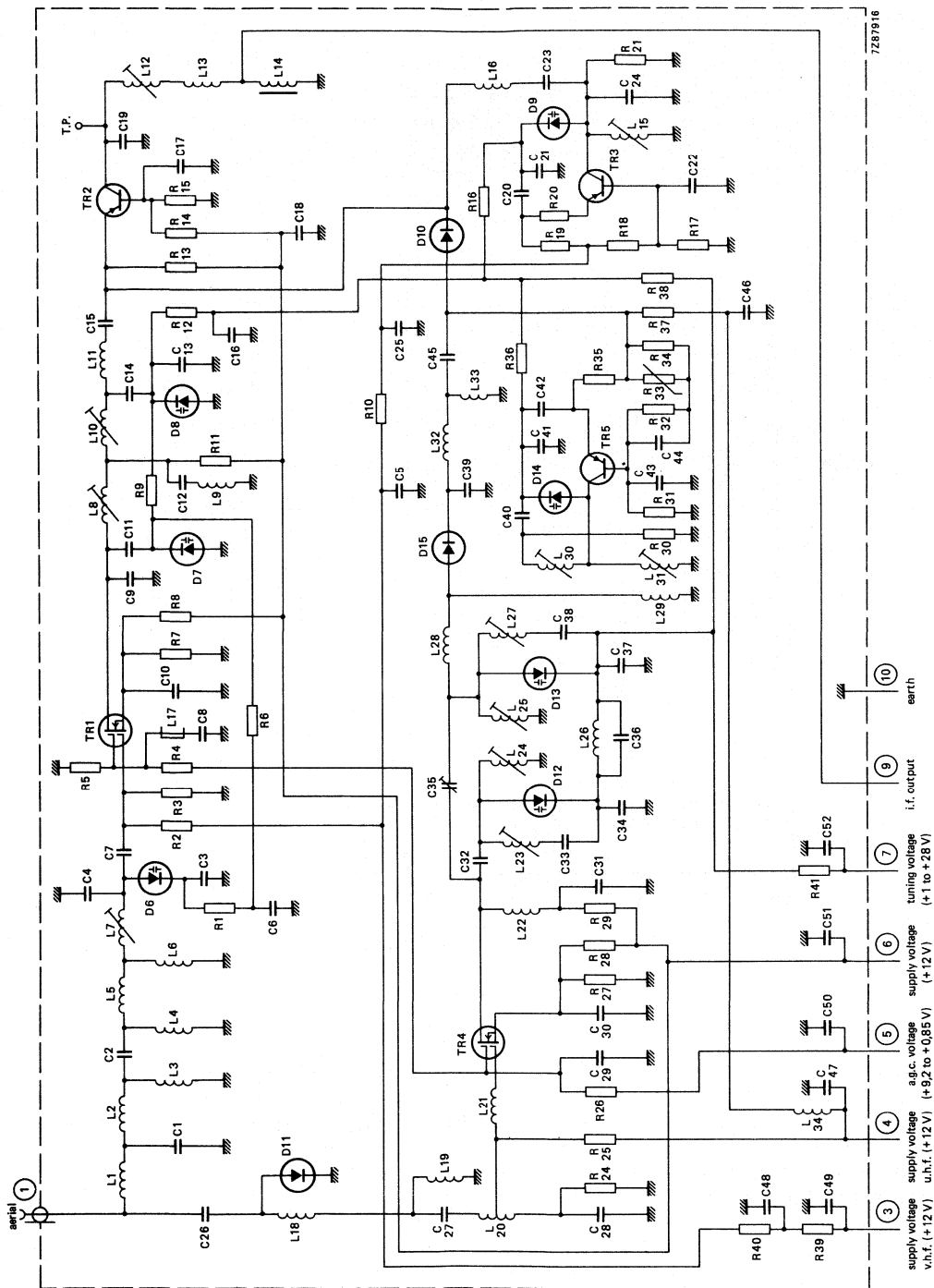

Fig. 1. Circuit diagram of the UV471.

MECHANICAL DATA

Dimensions in mm

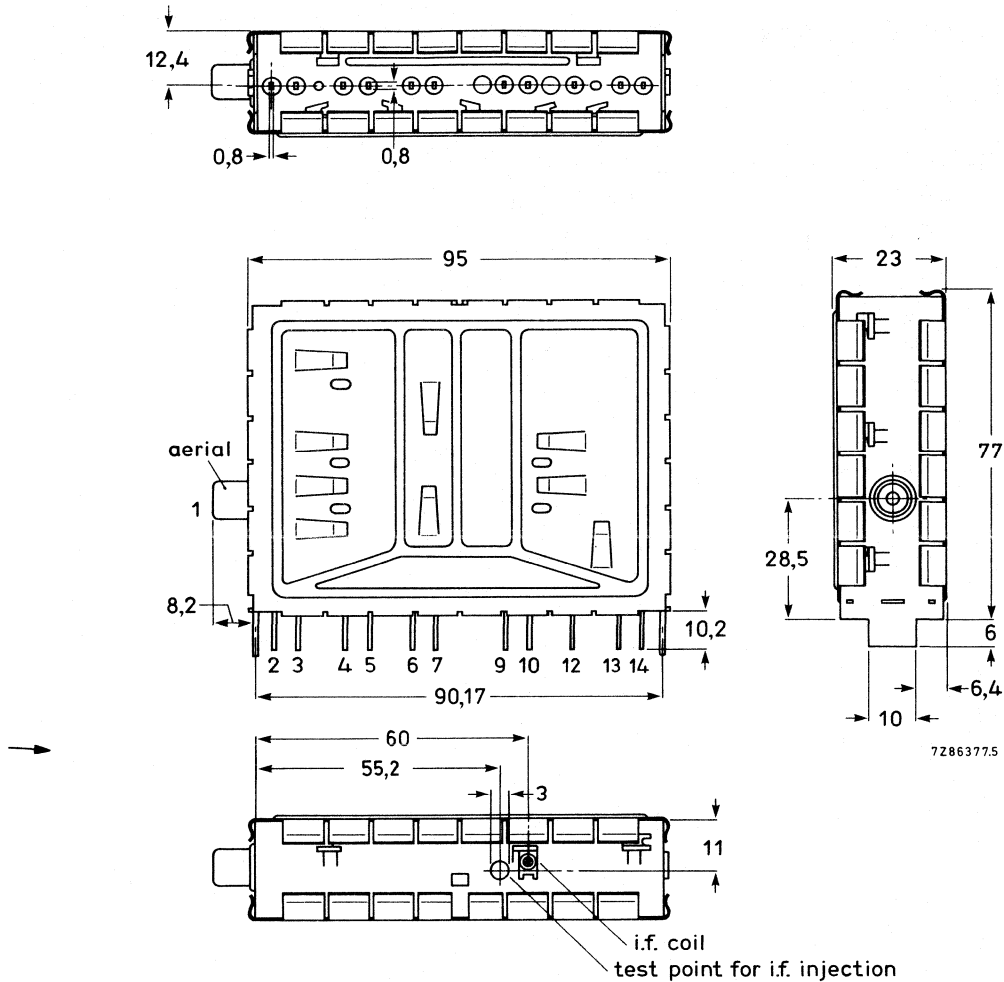
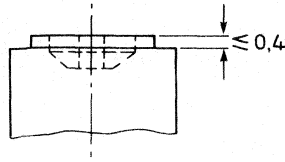

Fig. 2a.

Terminal

- | | | |
|--|---|--------------|
| 1 = aerial | 12, 13 = balanced output voltage of frequency divider | } UV472 only |
| 3 = supply voltage, v.h.f., + 12 V | 14 = supply voltage, frequency divider, + 5V | |
| 4 = supply voltage, u.h.f., + 12 V; i.f. injection | | |
| 5 = a.g.c. voltage, + 9,2 to + 0,85 V | | |
| 6 = supply voltage, v.h.f. and u.h.f., + 12 V | | |
| 7 = tuning voltage, + 1 to + 28 V | | |
| 9 = i.f. output | | |
| 10 = earth | | |

Fig. 2b I.F. output coil.
Torque for alignment: 2 to 15 mNm.
Press-through force: ≥ 10 N.



Mass approx. 127 g

Mounting

The tuner may be mounted by soldering it on to a printed-wiring board, using the piercing diagram shown in Fig. 3. (The tuner may also be mounted by means of a bracket. Information will be supplied upon request). The tuner may be mounted anywhere in the receiver and there are no restrictions on orientation.

The solderability of the terminals and mounting tabs is according to IEC 68-2, test Ta (230 ± 10 °C, $2 \pm 0,5$ s). The resistance to soldering heat is according to IEC 68-2, test Tb (260 ± 5 °C, 10 ± 1 s).

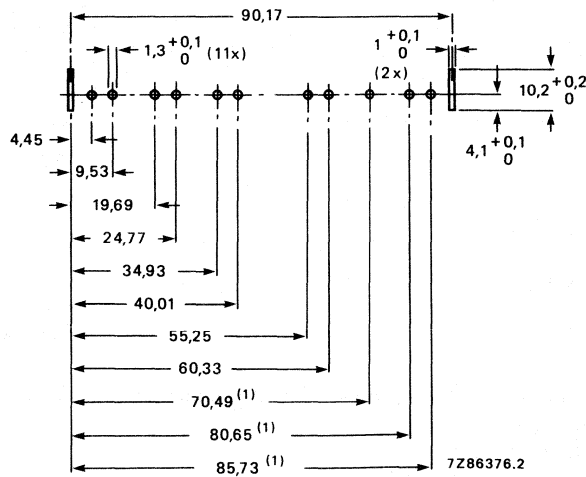

(1) Only for UV472

Fig. 3 Piercing diagram viewed from solder side of board. Unless otherwise stated the tolerance is $\pm 0,05$ mm.

ELECTRICAL DATA

Unless otherwise specified all electrical values apply at an ambient temperature of $25 \pm 5 \text{ }^\circ\text{C}$, a relative humidity of $60 \pm 15\%$, a supply voltage of $12 \pm 0,3 \text{ V}$ and an a.g.c. voltage of $9,2 \pm 0,2 \text{ V}$.

General

Semiconductors, v.h.f. band

r.f. amplifier	BF980
mixer	BF324
oscillator	BF926
tuning diodes	4 x BB405B
switching diodes	1 x BA482

Semiconductors, u.h.f. band

r.f. amplifier	BF980
oscillator	BF970
mixer	1SS99
tuning diodes	3 x BB405B
surge protection diodes	1 x BAV10

Frequency divider

SP4653 or SP4632

Ambient temperature range

operating	0 to + 55 $^\circ\text{C}$
storage	-25 to + 70 $^\circ\text{C}$

Relative humidity

max. 95%

Voltages and currents

Supply voltage

+ 12 V \pm 10%

Current drawn from + 12 V supply

v.h.f. band	max. 50 mA; typ. 31 mA
u.h.f. band	max. 50 mA; typ. 37 mA

Bandswitching

For operation in all bands the supply voltage is permanently connected to terminal 6. Additionally the supply voltage is connected to:

- terminal 3 for operation in the v.h.f. band
- terminal 4 for operation in the u.h.f. band

A.G.C. voltage (Figs 4 and 5)

voltage range	+ 9,2 to + 0,85 V
voltage at nominal gain	+ 9,2 \pm 0,5 V
voltage at 40 dB gain reduction	typ. 1,5 V
voltage at 30 dB gain reduction	typ. 2 V

} (v.h.f. band)

Note: A.G.C. voltages between 0 and + 10,5 V may be applied without risk of damage.

A.G.C. current

max. 0,3 mA

Slope of a.g.c. characteristic,

at the end of the specified a.g.c. range	
v.h.f. band	typ. 25 dB/V
u.h.f. band	typ. 50 dB/V

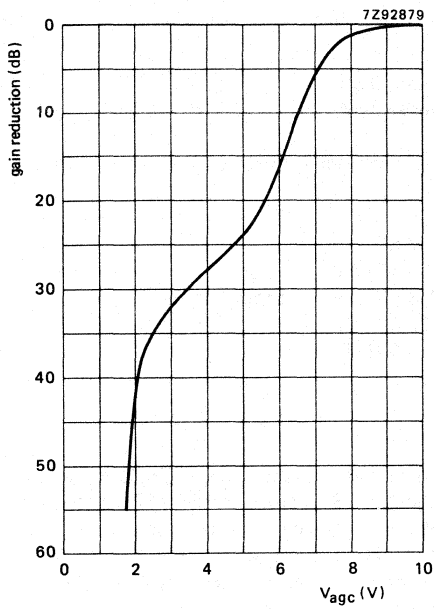

Fig. 4 Typical a.g.c. characteristic, v.h.f. band.

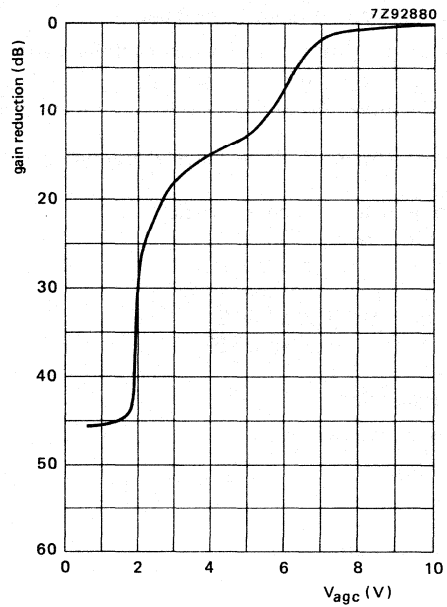

Fig. 5 Typical a.g.c. characteristic, u.h.f. band.

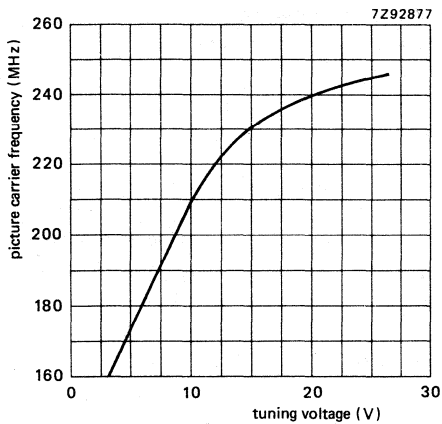

Fig. 6 Typical tuning characteristic, v.h.f. band.

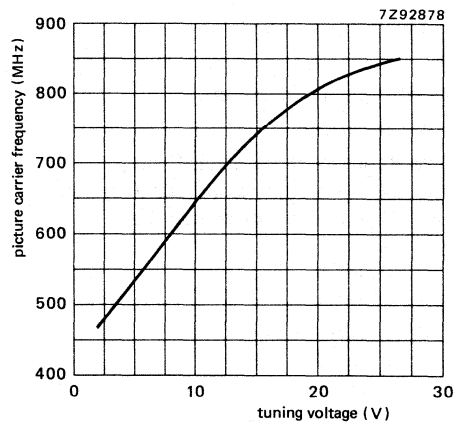

Fig. 7 Typical tuning characteristic, u.h.f. band.

UV471 UV472

Tuning voltage range (Figs 6 and 7) + 1 to + 28 V

Current drawn from 28 V tuning voltage supply
 at $T_{amb} = 25\text{ }^{\circ}\text{C}$ max. $0,5\text{ }\mu\text{A}$
 at $T_{amb} = 55\text{ }^{\circ}\text{C}$ max. $2\text{ }\mu\text{A}$

Note: The source impedance of the tuning voltage offered to terminal 7 must be maximum $47\text{ k}\Omega$.

Slope of tuning characteristic		
v.h.f. band, channel 4	7 MHz/V	} typical values
channel 8	6 MHz/V	
channel 13	1,8 MHz/V	
u.h.f. band, channel 21	22 MHz/V	
channel 69	4 MHz/V	

Frequencies

Frequency ranges

v.h.f.	channel 4 (picture carrier 175,25 MHz) to channel 13 (picture carrier 247,43 MHz). Margin at the extreme channels: min. 2 MHz.
u.h.f. band	channel 21 (picture carrier 471,25 MHz) to channel 69 (picture carrier 855,25 MHz). Margin at the extreme channels: min. 3 MHz.

Intermediate frequencies

picture	38,9 MHz
sound	32,9 MHz
	The oscillator frequency is higher than the aerial signal frequency

Wanted signal characteristics

Input impedance

75 Ω

V.S.W.R. and reflection coefficient (values between picture and sound carrier, as well as values at picture carrier)

v.s.w.r.	<u>at nominal gain</u>	<u>during gain control</u>
v.h.f. band,	max. 4	max. 5
u.h.f. band	max. 5	max. 7
reflection coefficient		
v.h.f. band	max. 60%	max. 66%
u.h.f. band	max. 66%	max. 75%

R.F. curves, bandwidth

v.h.f. band	typ. 10 MHz
u.h.f. band	typ. 17 MHz

R.F. curves, tilt

on any channel the amplitude difference between the top of the r.f. resonant curve and the picture frequency, the sound frequency, or any frequency between them will not exceed 3 dB at nominal gain, and 4 dB in the a.g.c. range between nominal gain and 20 dB gain reduction.

A.G.C. range		
v.h.f. band	min.	40 dB
u.h.f. band	min.	30 dB
Power gain (see also Measuring method of power gain)		
v.h.f. band	min.	22 dB
channel 4	typ.	31 dB
channel 7	typ.	30 dB
channel 10	typ.	31 dB
channel 13	typ.	31 dB
u.h.f. band	min.	20 dB
channel 21	typ.	32 dB
channel 40	typ.	31 dB
channel 69	typ.	32 dB
Maximum gain difference		
between any two v.h.f. channels	typ.	4 dB
between any two u.h.f. channels	typ.	4 dB
between any v.h.f. and u.h.f. channel	typ.	6 dB
Noise figure		
v.h.f. band	max.	8 dB
channel 4	max.	4,5 dB
channel 7	typ.	4,5 dB
channel 10	typ.	4,5 dB
channel 13	typ.	4,5 dB
u.h.f. band	max.	10 dB
channel 21	typ.	6 dB
channel 40	typ.	6 dB
channel 69	typ.	7 dB
Overloading		
Input signal producing 1 dB gain compression at nominal gain		
v.h.f. band	typ.	90 dB (μ V) into 75 Ω
u.h.f. band	typ.	90 dB (μ V) into 75 Ω
Input signal producing either a detuning of the oscillator of + 300 kHz or -1000 kHz or stopping of the oscillations at nominal gain		
v.h.f. band	typ.	100 dB (μ V) into 75 Ω
u.h.f. band	typ.	100 dB (μ V) into 75 Ω
Unwanted signal characteristics		
Image rejection (measured at picture carrier frequency)		
v.h.f. band	min.	60 dB; typ. 75 dB
u.h.f. band	min.	44 dB; typ. 53 dB
I.F. rejection (measured at picture carrier frequency)		
v.h.f. band	min.	60 dB
u.h.f. band	min.	60 dB

Note: At colour sub-carrier frequency maximum 6 dB less rejection.

N ± 4 rejection (for u.h.f. only)

Interference signal for an interference ratio of 53 dB referred to wanted picture carrier (picture to sound carrier ratio of 10 dB; wanted 60 dB (μV); tuner operating at nominal gain)

typ. 75 dB (μV) into 75 Ω

Cross modulation

Input signal producing 1% cross modulation, i.e. 1% of the modulation depth of the interfering signal is transferred to the wanted signal.

In channel cross modulation (wanted signal: picture carrier frequency; interfering signal: sound carrier frequency)

v.h.f. band

at nominal gain (wanted input level 60 dB (μV))

typ. 74 dB (μV) into 75 Ω

at 40 dB gain reduction (wanted input level 100 dB (μV))

typ. 94 dB (μV) into 75 Ω

u.h.f. band

at nominal gain (wanted input level 60 dB (μV))

typ. 74 dB (μV) into 75 Ω

at 30 dB gain reduction (wanted input level 90 dB (μV))

typ. 94 dB (μV) into 75 Ω

In band cross modulation (wanted signal: picture carrier of channel N; interfering signal: picture carrier of channel N ± 3 for v.h.f. or channel N ± 5 for u.h.f.)

v.h.f. band

at nominal gain (wanted input level 60 dB (μV))

typ. 82 dB (μV) into 75 Ω

at 40 dB gain reduction (wanted input level 100 dB (μV))

typ. 94 dB (μV) into 75 Ω

u.h.f. band

at nominal gain (wanted input level 60 dB (μV))

typ. 82 dB (μV) into 75 Ω

at 30 dB gain reduction (wanted input level 90 dB (μV))

typ. 94 dB (μV) into 75 Ω

Out of band cross modulation at nominal gain

v.h.f. interfering from u.h.f.

typ. 90 dB (μV) into 75 Ω

u.h.f. interfering from v.h.f.

typ. 86 dB (μV) into 75 Ω

Oscillator characteristics

Pulling

Input signal of tuned frequency producing a shift of the oscillator frequency of 10 kHz, at nominal gain

v.h.f. band

typ. 80 dB (μV) into 75 Ω

u.h.f. band

typ. 80 dB (μV) into 75 Ω

Shift of oscillator frequency at a change of the supply voltage of 5%

v.h.f. band

max. 200 kHz

u.h.f. band

max. 400 kHz

Drift of oscillator frequency

during warm-up time (after the tuner has been completely out of operation for 15 min, measured between 5 s and 15 min after switching on)

max. 250 kHz

during warm-up time (after the input stage is in operation for 15 min, measured between 2 s and 15 min after band switching)

max. 250 kHz

Drift of oscillator frequency

at a change of the ambient temperature
from + 25 to + 50 °C (measured after
3 cycles from + 25 to + 55 °C)

v.h.f. band
u.h.f. band

max. 600 kHz
max. 1000 kHz

Frequency divider characteristics (UV472 only)

Division ratio

256 or 64

Supply voltage

+ 5 V ± 10%

Current drawn from + 5 V supply

max. 55 mA

Output voltage, unloaded, measured with probe 10 MΩ/11 pF

min. 0,5 V_{p-p}

Output impedance

typ. 1 kΩ

Output imbalance

max. 0,1 V

Interference signal on the i.f. output

max. 3 μV

Note: I.F. output of the tuner terminated with 10 MΩ/11 pF

I.F. circuit characteristics

Bandwidth of i.f. output circuit

5 ± 1 MHz

Note: I.F. output of the tuner terminated with the circuit shown in Fig. 8; tuning voltage 25 V; u.h.f. band switched on.

Bandwidth variation of i.f. output circuit as a result of r.f. tuning
and band switching (reference: u.h.f.; tuning voltage 25 V)

max. 500 kHz

Note: I.F. output of the tuner terminated with a modified circuit of Fig. 8, i.e. a 100 pF capacitor is connected in parallel with the i.f. output of the tuner.

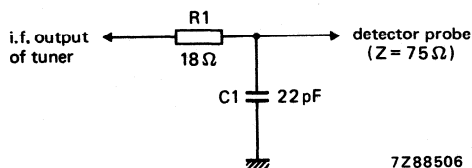

Fig. 8.

Detuning of the i.f. output circuit as a
result of r.f. tuning and band switching
(reference: u.h.f.; tuning voltage 25 V)

max. 500 kHz

Note: I.F. output of the tuner terminated with a modified circuit of Fig. 8, i.e. a 100 pF capacitor is connected in parallel with the i.f. output of the tuner.

Minimum tuning range of i.f. output coil

32,5 to 40 MHz

Note: I.F. output of the tuner terminated with the circuit shown in Fig. 8.

Attenuation between i.f. injection point
and i.f. output of the tuner

typ. 16 dB

Miscellaneous

Radio interference
Oscillator radiation and oscillator
voltage at the aerial terminal

Within the limits of C.I.S.P.R. 13
(1975) and S.A.B.S. requirements

Microphonics

There will be no microphonics,
provided the tuner is installed
in a professional manner.

Surge protection
Protection against voltages

max. 5 kV

Note: 10 discharges of a 470 pF capacitor into the aerial terminal.

Protection against flashes

max. 30 kV, 400 mWs

Note: A flashover circuit producing flashes with frequencies of 1 to 20 Hz for 30 s is connected to the aerial terminal.

ADDITIONAL INFORMATION

I.F. injection

Terminal 4 (supply voltage u.h.f.) can be used as i.f. injection point, provided the u.h.f. supply voltage is applied to terminal 4 via a resistor of 10 Ω (see Fig. 9). The u.h.f. band should be switched on; tuning voltage should be 25 V.

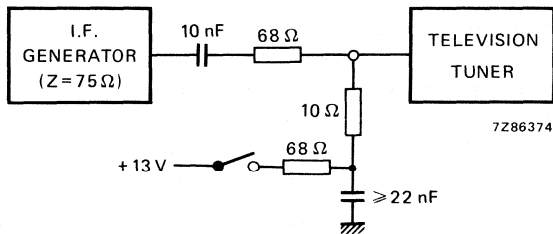

Fig. 9.

Connection of the i.f. amplifier

No special precautions are required to load and to match the i.f. output of the tuner.

Connection of supply voltages

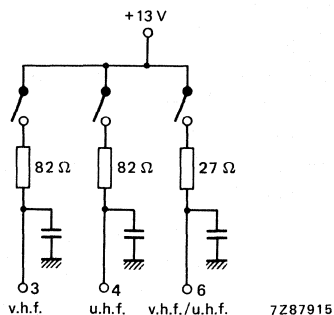

Fig. 10.

Measuring method of power gain

The i.f. output of the tuner should be terminated with the RC-circuit given in Fig. 8.

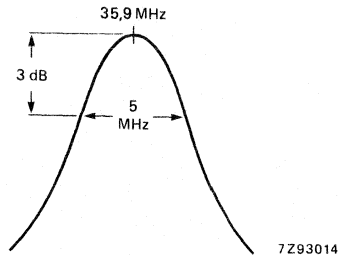

Fig. 11.

The RC-circuit roughly matches the i.f. output impedance to 75Ω at the resonant frequency of the i.f. output circuit, which should be tuned to 36,15 MHz; the bandwidth is approx. 5 MHz (Fig. 11).

Because the input and output impedances of the tuner are now 75Ω , the power gain can be measured in the conventional manner by inserting tuner and RC-circuit between a 75Ω source and a 75Ω detector.

Alignment of the i.f. output coil

The i.f. output coil should be adjusted with a plastic tool, which has a cross head as shown in Fig. 12. A suitable tool for automatic alignment is available under catalogue number 8104 004 11040.

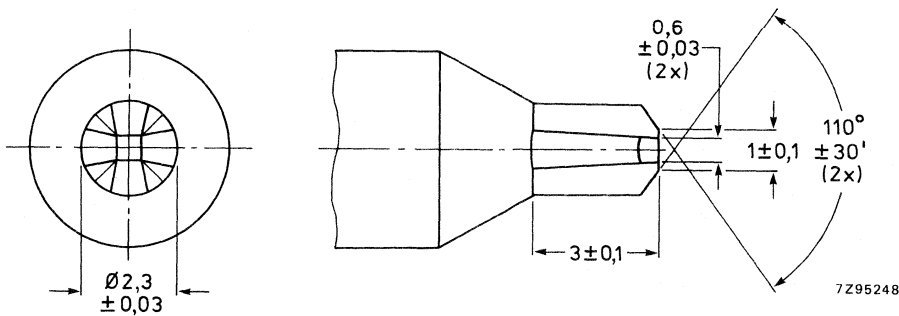

Fig. 12.

DEVELOPMENT DATA

This data sheet contains advance information and specifications are subject to change without notice.

UV615
UV616/256

V.H.F./U.H.F. TELEVISION TUNERS

QUICK REFERENCE DATA

Systems	C.C.I.R. systems B, G and H	
Channels	off-air	cable
low v.h.f.	E2 to C	S01 to S1
high v.h.f.	E5 to E12	S2 to S20
hyperband		S21 to S41
u.h.f.	E21 to E69	
Intermediate frequencies		
picture	38,90 MHz	
colour	34,47 MHz	
sound 1	33,40 MHz	
sound 2	33,16 MHz	

APPLICATION

Designed to cover the v.h.f. and u.h.f. channels of C.C.I.R. systems B, G and H with extended v.h.f. frequency ranges, including the hyperband.

The i.f. output is designed for direct drive of a variety of SAW filters.

The tuner UV616/256 is equipped with a frequency divider, which makes it suitable for digital tuning systems based on frequency synthesis; for the remainder it is equal to type UV615.

Available versions

	aerial input connector	frequency divider (IC)	catalogue number
UV615	IEC	—	3112 218 53600
UV616/256	IEC	1 : 256	3112 218 53420

Both tuners comply with the requirements of radiation, signal handling capability, and immunity from radiated interference of Amtsblatt DBP69/1981, when installed professionally in an adequate TV receiver.

UV615 UV616/256

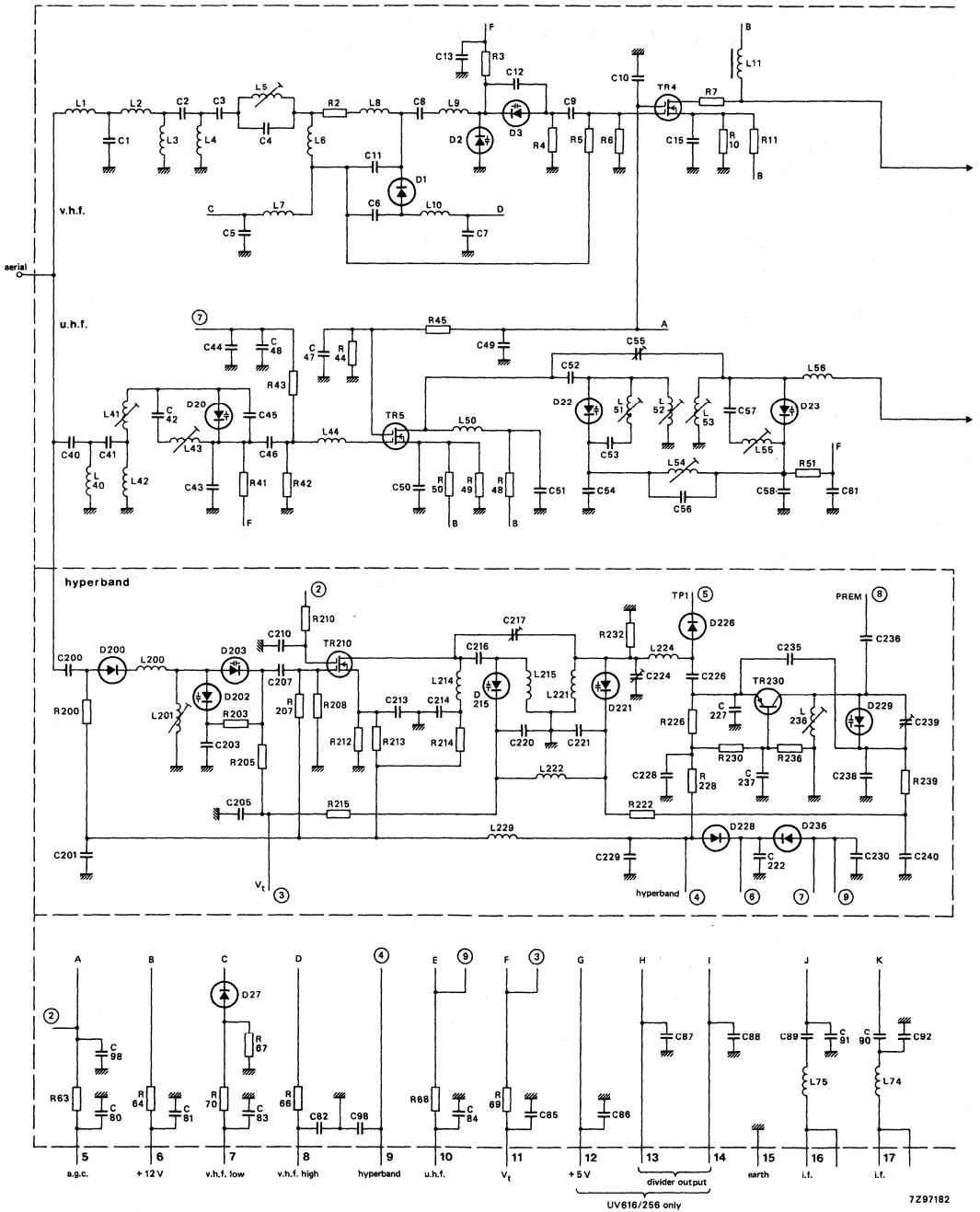

UV616/256 only

7297182

DESCRIPTION

The UV615 and UV616/256 are combined v.h.f./u.h.f. tuners with electronic tuning and band switching, covering the low v.h.f. band (frequency range 46 to 110 MHz), the high v.h.f. band (frequency range 111 to 300 MHz), the hyperband (frequency range 300 to 470 MHz), and the u.h.f. band (frequency range 470 to 860 MHz).

Mechanically, the tuners are built on a low-loss printed-wiring board, carrying all components, in a die-cast metal housing made of a rectangular frame and front and rear covers (see Fig. 2). The common IEC coaxial aerial connector (75Ω) is integrated in one of the frame sides of the housing, all other connections (supply voltages, a.g.c. voltage, tuning and switching voltages, i.f. output) are made via terminals in the underside. The mounting method is shown in Fig. 3.

Electrically, the tuners consist of v.h.f., hyperband and u.h.f. parts (see Fig. 1). They are equipped with a common aerial input and provided with tuned r.f. MOSFET input stages. The v.h.f. mixer, v.h.f. oscillator and i.f. amplifier functions are provided by a tuner IC. This IC has terminals between mixer and i.f. amplifier to connect i.f. preselections, a 40,4 MHz trap is provided to improve the selectivity of common SAW filters for adjacent channel N - 1 (system B).

Output impedance of the symmetrical i.f. terminals is approx. 75Ω to insure sufficient triple transient suppression of the SAW filter.

The r.f. band pass filter and oscillator circuits of the v.h.f. part are tuned by 7 tuning diodes; band switching is achieved by 4 switching diodes, those of the hyperband by 4 tuning diodes and 1 switching diode respectively.

The u.h.f. part of the tuner has a high-pass input circuit connected to gate 1 of an input MOSFET tetrode (with internal gate protection against surge). The drain load of this MOSFET tetrode is formed by a double tuned circuit transferring the r.f. signal to the Schottky barrier mixer diode. The i.f. signal from the mixer diode is amplified by the i.f. pre-amplifier of the tuner I.C.

The r.f. band pass filter and oscillator circuits are tuned by 4 tuning diodes.

In all bands the tuner is gain-controlled via gate 2 of the input MOSFET tetrode.

A test point TP1 is provided for i.f. injection.

The electrical circuit of the UV616/256 is extended with a frequency divider (division ratio of 256), with an input connected to the v.h.f., hyperband and u.h.f. oscillators. The symmetrical ECL outputs are connected to terminals 13 and 14.

MECHANICAL DATA

Dimensions in mm

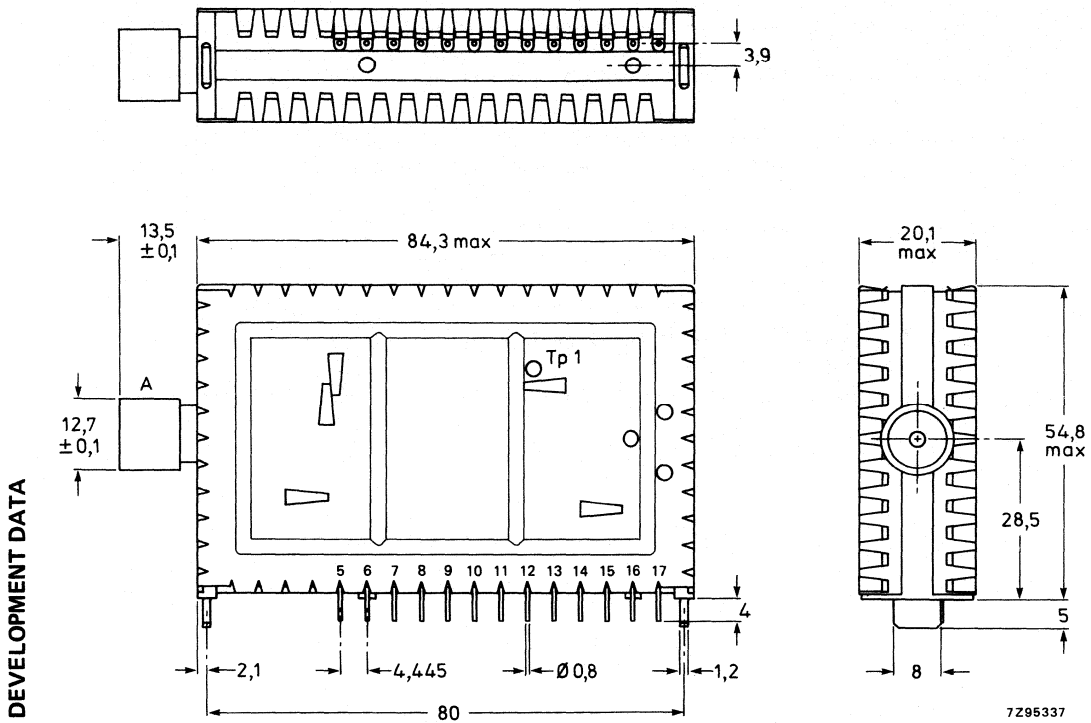

Unless otherwise stated the tolerance is $\pm 0,05$ mm.

Fig. 2.

Terminal

- | | | |
|--|---|----------------------|
| A = aerial input (IEC female 75 Ω) | 12 = supply voltage, frequency divider, + 5 V | } only for UV616/256 |
| 5 = a.g.c. voltage, + 9,2 to + 0,85 V | 13, 14 = balanced output voltage of frequency divider (1 k Ω) | |
| 6 = supply voltage, tuning part, + 12 V | 15 = earth | |
| 7 = supply voltage, low v.h.f., + 12 V | 16 = } i.f. output, symm. (approx. 75 Ω) | |
| 8 = supply voltage, high v.h.f., + 12 V | 17 = } | |
| 9 = supply voltage, hyperband, + 12 V | | |
| 10 = supply voltage, u.h.f., + 12 V | | |
| 11 = tuning voltage, + 0,8 to + 28 V | | |

Mass approx. 99 g

Mounting

The tuner may be mounted by soldering it on to a printed-wiring board (using the piercing diagram shown in Fig. 3) without clearance between tuner supporting surface and board. The connection pins should be bent according to Fig. 4. The tuner may be mounted anywhere in the receiver and there are no restrictions on orientation.

The solderability of the terminals and mounting tabs is according to IEC 68-2, test Ta ($230 \pm 10 \text{ }^\circ\text{C}$, $2 \pm 0,5 \text{ s}$). The resistance to soldering heat is according to IEC 68-2, test Tb ($260 \pm 5 \text{ }^\circ\text{C}$, $10 \pm 1 \text{ s}$).

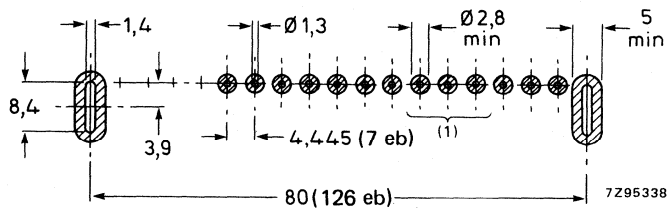

(1) Only for UV616/256

1 eb = 0,025 inch

Fig. 3 Piercing diagram viewed from solder side of board. Unless otherwise stated the tolerance is $\pm 0,05 \text{ mm}$.

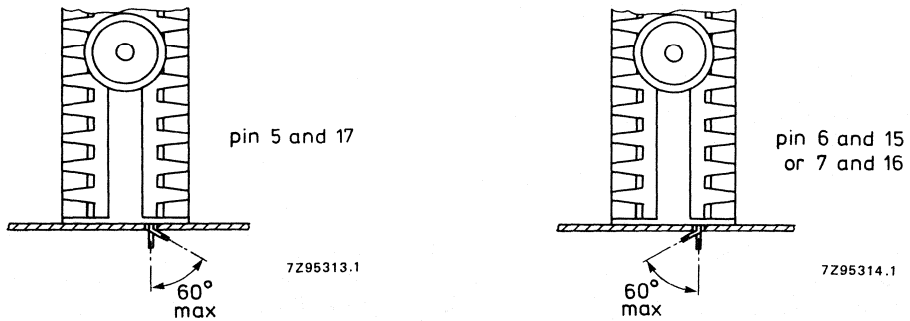

Fig. 4.

In order to prevent any stress to the printed-wiring board, the tuner should be supported at its aerial connector.

ELECTRICAL DATA

Unless otherwise specified all electrical values apply at an ambient temperature of 25 ± 5 °C, a relative humidity of $60 \pm 15\%$, a supply voltage of $12 \pm 0,3$ V and an a.g.c. voltage of $9,2 \pm 0,2$ V.

General

Semiconductors, v.h.f. bands

r.f. amplifier	BF992
mixer	TDA5030
oscillator	
tuning diodes	7 x OF633
switching diodes	4 x BA482/483/484
d.c. blocking diodes	2 x BAS15

Semiconductors, hyperband

r.f. amplifier	BF990
oscillator	BF569
mixer	1SS99
tuning diodes	5 x OF643
switching diodes	1 x BA482
d.c. blocking diodes	2 x BAW62

Semiconductors, u.h.f. bands

r.f. amplifier	BF990
oscillator	BF970
mixer	1SS99
tuning diodes	4 x OF643

Frequency divider

SP4653

Ambient temperature range

operating	-10 to + 60 °C
storage	-25 to + 70 °C

Relative humidity

max. 95%

Voltages and currents

Supply voltage

+ 12 V \pm 10%

Current drawn from + 12 V supply

v.h.f. bands	max. 50 mA
u.h.f. bands	max. 45 mA

Bandswitching

max. 15 mA (hyperband max. 20 mA)

For operation in all bands the supply voltage is permanently connected to terminal 6. Additionally the supply voltage is connected to:

- terminal 7 for operation in low v.h.f. band
- terminal 8 for operation in high v.h.f. band
- terminal 9 for operation in the hyperband
- terminal 10 for operation in u.h.f. bands

A.G.C. voltage	
voltage range	+ 9,2 to 0,85 V (max. 30 μ A)
voltage at nominal gain	+ 9,2 \pm 0,5 V
voltage at 40 dB gain reduction	
low v.h.f. band	typ. 3 V
high v.h.f. band and hyperband	typ. 2 V
voltage at 30 dB gain reduction	
u.h.f. band	typ. 2 V

Note: A.G.C. voltage between 0 and + 10,5 V may be applied without risk of damage.

→ A.G.C. current max. 0,03 mA

Slope of a.g.c. characteristic
at the end of the specified a.g.c. range

low v.h.f. band	typ. 40 dB/V
high v.h.f. band	typ. 80 dB/V
→ hyperband	typ. 50 dB/V

Tuning voltage range

+ 1 to + 28 V

Current drawn from 28 V tuning voltage supply

at $T_{amb} = 25\text{ }^{\circ}\text{C}$ and 60% R.H.	max. 0,5 μ A
at $T_{amb} = 25\text{ }^{\circ}\text{C}$ and 95% R.H.	max. 2 μ A
at $T_{amb} = 60\text{ }^{\circ}\text{C}$ and 60% R.H.	max. 2 μ A

Note: The source impedance of the tuning voltage offered to terminal 11 must be maximum 47 k Ω .

Slope of tuning characteristic

low v.h.f. band, channel E2	5 MHz/V	} typical values
channel S1	1 MHz/V	
high v.h.f. band, channel S2	10 MHz/V	
channel S20	2 MHz/V	
hyperband, channel H21	8 MHz/V	
channel H41	14 MHz/V	
u.h.f. bands, channel E21	22 MHz/V	
channel E69	5 MHz/V	

Frequencies

Frequency ranges

low v.h.f. band	channel E2 (picture carrier 48,25 MHz) to channel S1 (picture carrier 105,25 MHz). Margin at the extreme channels: min. 2 MHz.
high v.h.f. band	channel S2 (picture carrier 112,25 MHz) to channel S20 (picture carrier 294,25 MHz). Margin at the extreme channels: min. 2 MHz.
→ hyperband	channel S21 (picture carrier 303,25 MHz) to channel S41 (picture carrier 463,25 MHz). Margin at the extreme channels: min. 2 MHz.
u.h.f. bands	channel E21 (picture carrier 471,25 MHz) to channel E69 (picture carrier 855,25 MHz). Margin at the extreme channels: min. 3 MHz.

Intermediate frequencies

picture	38,90 MHz
colour	34,47 MHz
sound 1	33,40 MHz
sound 2	33,16 MHz

The oscillator frequency is higher than the
aerial signal frequency.

Wanted signal characteristics

Input impedance	75 Ω	
V.S.W.R. and reflection coefficient (values between picture and sound carrier, as well as values at picture carrier)		
v.s.w.r.	<u>at nominal gain and during gain control</u>	
v.h.f. bands	max. 4	
hyperband	max. 5	
u.h.f. bands	max. 5	
reflection coefficient		
v.h.f. bands	max. 60%	
hyperband	max. 66%	
u.h.f. bands	max. 66%	
Output impedance (i.f.)	75 Ω approx.	
Capacitance between terminals	typ. 3,5 pF	
Load impedance	min. 1 k Ω //max. 22 pF	
	total capacitance load to be tuned to 36,15 MHz by means of an inductance between terminals 16 and 17 (min. L: 890 nH) ←	
DEVELOPMENT DATA		
R.F. curves bandwidth		
low v.h.f. band	typ. 10 MHz	
high v.h.f. band	typ. 10 MHz	
hyperband	typ. 15 MHz	
u.h.f. bands	typ. 15 MHz	
R.F. curves, tilt	on any channel the amplitude difference between the top of the r.f. resonant curve and the picture frequency, the sound frequency, or any frequency between them will not exceed 3 dB at nominal gain, and 4 dB in the a.g.c. range between nominal gain and 20 dB gain reduction.	
A.G.C. range		
v.h.f. bands and hyperband	min. 40 dB	
u.h.f. bands	min. 30 dB	
Voltage gain		
low v.h.f. band	min. 40 dB; max. 50 dB	
high v.h.f. band		
channels S2 to S6	min. 36 dB; max. 46 dB	
channels S21 to S41	min. 40 dB; max. 50 dB	←
u.h.f. bands	min. 40 dB; max. 50 dB	
Maximum gain difference		
off. air channels	max. 5 dB	←
Noise figure		
v.h.f. bands		
E channels	typ. 5 dB; max. 8 dB	
S channels and hyperband channels	typ. 7 dB; max. 10 dB	
u.h.f. bands	typ. 8 dB; max. 11 dB	

Overloading

- Input signal producing 1 dB gain compression at nominal gain
v.h.f. bands and hyperband
→ u.h.f. bands
typ. 90 dB (μV) into 75 Ω
typ. 90 dB (μV) into 75 Ω
- Input signal producing either a detuning of the oscillator of + 300 kHz or -1000 kHz or stopping of the oscillations at nominal gain
v.h.f. bands
→ u.h.f. bands and hyperband
typ. 105 dB (μV) into 75 Ω ; min. 100 dB (μV)
typ. 100 dB (μV) into 75 Ω ; min. 90 dB (μV)

Unwanted signal characteristics

- Image rejection (measured at picture carrier frequency)
v.h.f. bands min. 66 dB; typ. 70 dB
hyperband min. 66 dB; typ. 70 dB
→ u.h.f. bands min. 53 dB; typ. 65 dB
- I.F. rejection (measured at picture carrier frequency)
all bands min. 60 dB

Note: At colour sub-carrier frequency maximum 6 dB less rejection.

Cross modulation

Input signal producing 1% cross modulation, i.e. 1% of the modulation depth of the interfering signal is transferred to the wanted signal.

In channel cross modulation (wanted signal: picture carrier frequency; interfering signal: sound carrier frequency)

- v.h.f. bands and hyperband
→ at nominal gain (wanted input level 60 dB (μV)) typ. 75 dB (μV) into 75 Ω
at 40 dB gain reduction (wanted input level 100 dB (μV)) typ. 100 dB (μV) into 75 Ω
- u.h.f. bands
→ at nominal gain (wanted input level 60 dB (μV)) typ. 75 dB (μV) into 75 Ω
at 30 dB gain reduction (wanted input level 90 dB (μV)) typ. 100 dB (μV) into 75 Ω

- In band cross modulation (wanted signal: picture carrier of channel N; interfering signal: picture carrier of channel N \pm 2 for low v.h.f., or channel N \pm 3 for high v.h.f., or channel N \pm 5 for u.h.f. and hyperband)

- v.h.f. bands and hyperband
at nominal gain (wanted input level 60 dB (μV)) typ. 95 dB (μV) into 75 Ω
at 40 dB gain reduction (wanted input level 100 dB (μV)) typ. 100 dB (μV) into 75 Ω
- u.h.f. bands
→ at nominal gain (wanted input level 60 dB (μV)) typ. 100 dB (μV) into 75 Ω
at 30 dB gain reduction (wanted input level 90 dB (μV)) typ. 100 dB (μV) into 75 Ω

Out of band cross modulation at nominal gain

- each of the v.h.f., u.h.f. or hyperbands
interfering with any of the other bands mentioned
typ. 100 dB (μV) into 75 Ω

Unwanted signal handling capability (visibility test)

For the channel combinations

v.h.f. and hyperband: $N \pm 1, N \pm 5, N + 11$

u.h.f.: $N \pm 1, N \pm 5, N + 9$

The tuner meets the requirements of "Amtsblatt" DBP/1981, item 5.1.2, when measured in an adequate TV receiver. ←

Oscillator characteristics**Pulling**

Input signal of tuned frequency producing a shift of the oscillator frequency of 10 kHz, at nominal gain

all bands

typ. 86 dB (μ V) into 75 Ω

Shift of oscillator frequency at a change of the supply voltage of $\pm 5\%$

v.h.f. bands

max. 250 kHz

hyperband

max. 500 kHz

u.h.f. bands

max. 500 kHz

Drift of oscillator frequency

during warm-up time (after the tuner has been completely out of operation for 15 min, measured between 5 s and 15 min after switching on)

max. 250 kHz

during warm-up time (after the input stage is in operation for 15 min, measured between 2 s and 15 min after band switching)

max. 250 kHz

at a change of the ambient temperature from + 25 to + 50 °C (measured after 3 cycles from + 25 to 0 °C)

v.h.f. bands

max. 500 kHz

hyperband

max. 750 kHz ←

u.h.f. bands

max. 1000 kHz

at a change of humidity from $60 \pm 15\%$ to $93 \pm 2\%$, at $T_{amb} = 25 \pm 5$ °C

low v.h.f. band

max. 500 kHz

high v.h.f. band

max. 1000 kHz

hyperband

max. 1300 kHz ←

u.h.f. bands

max. 1500 kHz

Frequency divider characteristics of the UV616/256

→ Division ratio	256
Supply voltage	+ 5 V ± 5%
Current drawn from + 5 V supply	max. 35 mA; typ. 25 mA
→ Output voltage, unloaded, measured with probe 10 MΩ/11 pF	min. 0,5 V _{p-p}
Output impedance	typ. 1 kΩ
Output imbalance	typ. 0,1 V
→ Interference signal on the i.f. output	max. 30 dB (μV)

Note: I.F. output of the tuner terminated with 10 MΩ/11 pF.

Miscellaneous

Radio interference
Oscillator radiation and oscillator voltage at the aerial terminal

Within the limits of C.I.S.P.R. 13 (1975), VDE0872/7.72. and Amtsblatt DBP69/1981, when applying the tuner in an adequate TV receiver

Microphonics

There will be no microphonics, provided the tuner is installed in a professional manner.

Surge protection
Protection against voltages

max. 5 kV

Note: 10 discharges of a 470 pF capacitor into the aerial terminal.

Protection against flashes

max. 30 kV, 400 mWs

Note: A flashover circuit producing flashes with frequencies of 1 to 20 Hz for 30 s is connected to the aerial terminal.

ADDITIONAL INFORMATION

I.F. injection

An i.f. signal from a generator (internal resistance 50 Ω or 75 Ω) should be connected to the i.f. injection point TP1, accessible through a hole in the cover (see Fig. 2) via a probe (see Fig. 5).

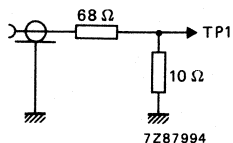

Fig. 5.

V.H.F./U.H.F. TELEVISION TUNERS

QUICK REFERENCE DATA

Systems	C.C.I.R. systems B, G and H
Channels	off-air cable
low v.h.f.	E2 - C S01 to S1
high v.h.f.	E5 - E12 S2 to S20
u.h.f.	E21 - E69
Intermediate frequencies	
picture	38,90 MHz
colour	34,47 MHz
sound 1	33,40 MHz
sound 2	33,16 MHz

APPLICATION

Designed to cover the v.h.f. and u.h.f. channels of C.C.I.R. systems B, G and H with extended v.h.f. frequency ranges.

The tuner UV618/256 is equipped with a frequency divider, which makes it suitable for digital tuning systems based on frequency synthesis; for the remainder it is equal to type UV617.

Available versions

	aerial input connector	frequency divider (IC)	catalogue number
UV617	IEC	—	3122 237 00060
UV618/256	IEC	1 : 256	3122 237 00010

Both tuners comply with the requirements of radiation, signal handling capability, and immunity from radiated interference of Amtsblatt DBP69/1981, when installed professionally in an adequate TV receiver.

DESCRIPTION

The UV617 and UV618/256 are combined v.h.f./u.h.f. tuners with electronic tuning and band switching, covering the low v.h.f. band (frequency range 46 to 110 MHz), the high v.h.f. band (frequency range 111 to 300 MHz), and the u.h.f. band (frequency range 470 to 860 MHz).

Mechanically, the tuners are built on a low-loss printed-wiring board, carrying all components, in a die-cast metal housing made of a rectangular frame and front and rear covers (see Fig. 2). The common IEC coaxial aerial connector (75Ω) is integrated in one of the frame sides of the housing, all other connections (supply voltages, a.g.c. voltage, tuning and switching voltages, i.f. output) are made via terminals in the underside. The mounting method is shown in Fig. 3.

Electrically, the tuners consist of v.h.f. and u.h.f. parts (see Fig. 1). They are equipped with a common aerial input and provided with r.f. MOSFET input stages. The v.h.f. mixer, v.h.f. oscillator and i.f. amplifier functions are provided by a tuner IC. This IC has terminals between mixer and i.f. amplifier to connect i.f. preselections, a 40,4 trap is provided to improve the selectivity of common SAW filters for adjacent channel N - 1 (system B).

Output impedance of the symmetrical i.f. terminals is approx. 75Ω to insure sufficient triple transient suppression of the SAW.

The r.f. band pass filter and oscillator circuits are tuned by 7 tuning diodes; band switching is achieved by 4 switching diodes.

The u.h.f. part of the tuner has a high-pass input circuit connected to gate 1 of an input MOSFET tetrode (with internal gate protection against surge). The drain load of this MOSFET tetrode is formed by a double tuned circuit transferring the r.f. signal to the Schottky barrier mixer diode. The i.f. signal from the mixer diode is amplified by the i.f. pre-amplifier of the tuner I.C..

The r.f. band pass filter and oscillator circuits are tuned by 4 tuning diodes.

In all bands the tuner is gain-controlled via gate 2 of the input MOSFET tetrode.

A test point TP1 is provided for i.f. injection.

The electrical circuit of the UV618/256 is extended with a frequency divider (division ratio of 256), with inputs connected to the v.h.f. and u.h.f. oscillator. The symmetrical ECL outputs are connected to terminals 13 and 14.

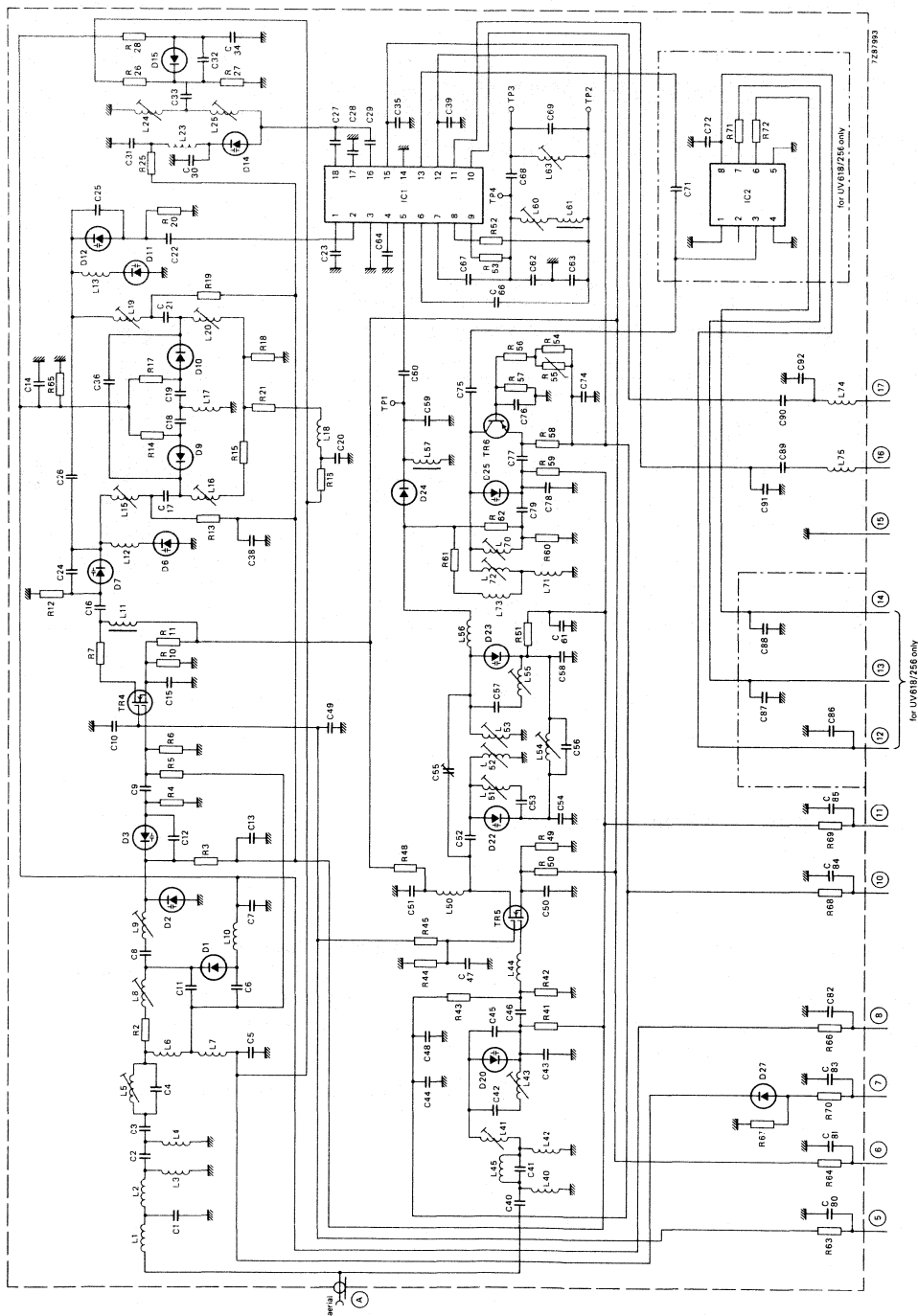
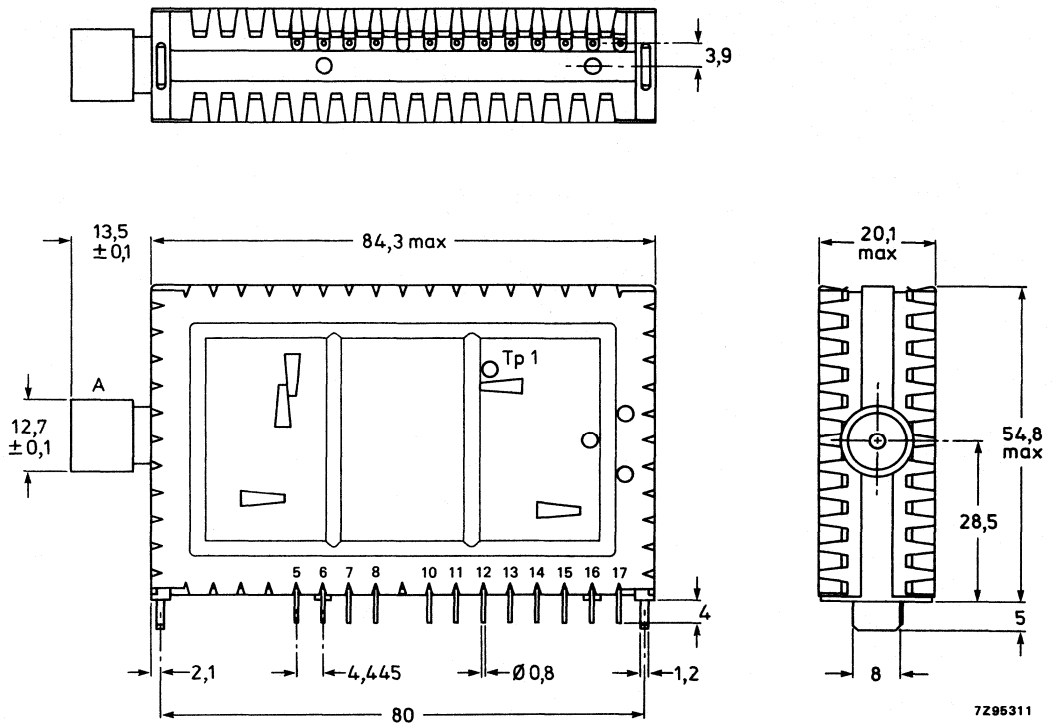

Fig. 1.

For type UV617 delete: C71, C72, C86, C87, C88, R71, R72, IC2.
For connections see next page.

MECHANICAL DATA

Dimensions in mm



Unless otherwise stated the tolerance is $\pm 0,05$ mm.

Fig. 2.

Terminal

- | | | |
|--|--|----------------------|
| A = aerial input (IEC female 75 Ω) | 12 = supply voltage, frequency divider, + 5 V | } only for UV618/256 |
| 5 = a.g.c. voltage, + 9,2 to + 0,85 V | 13,14 = balanced output voltage of frequency divider (1 k Ω) | |
| 6 = supply voltage, tuning part, + 12 V | 15 = earth | |
| 7 = supply voltage, low v.h.f., + 12 V | 16 = } | |
| 8 = supply voltage, high v.h.f., + 12 V | 17 = } | |
| 10 = supply voltage, u.h.f., + 12 V | | |
| 11 = tuning voltage, + 0,8 to + 28 V | | |

Mass approx. 95 g

Mounting

The tuner may be mounted by soldering it on to a printed-wiring board (using the piercing diagram shown in Fig. 3) without clearance between tuner supporting surface and board. The connection pins should be bent according to Fig. 4. The tuner may be mounted anywhere in the receiver and there are no restrictions on orientation.

The solderability of the terminals and mounting tabs is according to IEC 68-2, test Ta ($230 \pm 10 \text{ }^\circ\text{C}$, $2 \pm 0,5 \text{ s}$). The resistance to soldering heat is according to IEC 68-2, test Tb ($260 \pm 5 \text{ }^\circ\text{C}$, $10 \pm 1 \text{ s}$).

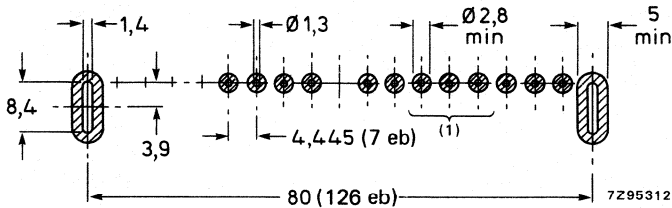

(1) Only for UV618/256

1 eb = 0,025 inch

Fig. 3 Piercing diagram viewed from solder side of board. Unless otherwise stated the tolerance is $\pm 0,05 \text{ mm}$.

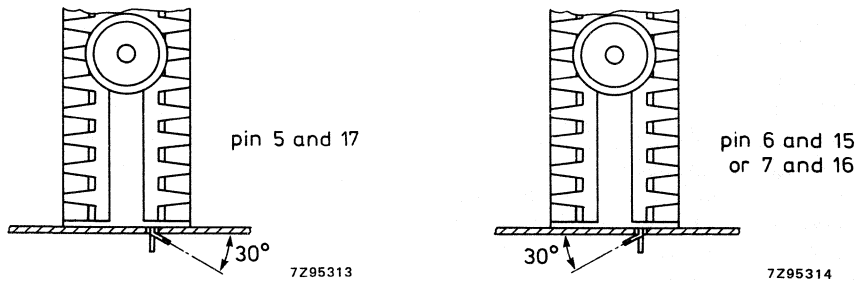

Fig. 4.

In order to prevent any stress to the printed-wiring board, the tuner should be supported at its aerial connector.

ELECTRICAL DATA

Unless otherwise specified all electrical values apply at an ambient temperature of $25 \pm 5^\circ\text{C}$, a relative humidity of $60 \pm 15\%$, a supply voltage of $12 \pm 0,3\text{ V}$ and an a.g.c. voltage of $9,2 \pm 0,2\text{ V}$.

General

Semiconductors, v.h.f. bands

r.f. amplifier	BF992
mixer	TDA5030
oscillator	
tuning diodes	7 x OF633
switching diodes	4 x BA482/483/484
d.c. blocking diodes	2 x BAS15

Semiconductors, u.h.f. bands

r.f. amplifier	BF990
oscillator	BF970
mixer	1SS99
tuning diodes	4 x OF643
frequency divider	SP4653

Ambient temperature range

operating	-10 to $+60^\circ\text{C}$
storage	-25 to $+85^\circ\text{C}$

Relative humidity

max. 95%

Voltages and currents

Supply voltage

$+12\text{ V} \pm 10\%$

Current drawn from + 12 V supply

v.h.f. bands	max. 50 mA
u.h.f. bands	max. 45 mA

Bandswitching

max. 15 mA

For operation in all bands the supply voltage is permanently connected to terminal 6. Additionally the supply voltage is connected to:

- terminal 7 for operation in low v.h.f. band
- terminal 8 for operation in high v.h.f. band
- terminal 10 for operation in u.h.f. bands

A.G.C. voltage (Figs 4, 5 and 6)

voltage range	$+9,2$ to $+0,85\text{ V}$ (max. 30 μA)
voltage at nominal gain	$+9,2 \pm 0,5\text{ V}$
voltage at 40 dB gain reduction	
low v.h.f. band	typ. 3 V
high v.h.f. band	typ. 2 V
voltage at 30 dB gain reduction	
u.h.f. band	typ. 2 V

Note: A.G.C. voltage between 0 and $+10,5\text{ V}$ may be applied without risk of damage.

→ A.G.C. current max. 0,03 mA

Slope of a.g.c. characteristic,

at the end of the specified a.g.c. range

low v.h.f. bands	typ. 40 dB/V
high v.h.f. bands	typ. 80 dB/V

Tuning voltage range (Figs 7, 8 and 9)	+ 0,8 to + 28 V
Current drawn from 28 V tuning voltage supply	
at $T_{amb} = 25\text{ }^{\circ}\text{C}$ and 60% R.H.	max. 0,5 μA
at $T_{amb} = 25\text{ }^{\circ}\text{C}$ and 95% R.H.	max. 2 μA
at $T_{amb} = 60\text{ }^{\circ}\text{C}$ and 60% R.H.	max. 2 μA
Note: The source impedance of the tuning voltage offered to terminal 11 must be maximum 47 k Ω .	
Slope of tuning characteristic	
low v.h.f. band, channel E2	5 MHz/V
channel S1	1 MHz/V
high v.h.f. band, channel S2	10 MHz/V
channel S20	2 MHz/V
u.h.f. bands, channel E21	22 MHz/V
channel E69	5 MHz/V
	} typical values
Frequencies	
Frequency ranges	
low v.h.f. band	channel E2 (picture carrier 48,25 MHz) to channel S1 (picture carrier 105,25 MHz). Margin at the extreme channels: min. 2 MHz.
high v.h.f. band	channel S2 (picture carrier 112,25 MHz) to channel S20 (picture carrier 294,25 MHz). Margin at the extreme channels: min 2 MHz.
u.h.f. bands	channel E21 (picture carrier 471,25 MHz) to channel E69 (picture carrier 855,25 MHz). Margin at the extreme channels: min 3 MHz.
Intermediate frequencies	
picture	38,90 MHz
colour	34,47 MHz
sound 1	33,40 MHz
sound 2	33,16 MHz
	The oscillator frequency is higher than the aerial signal frequency.
Wanted signal characteristics	
Input impedance	75 Ω
V.S.W.R. and reflection coefficient (values between picture and sound carrier, as well as values at picture carrier)	
v.s.w.r.	at nominal gain and during gain control
v.h.f. bands	max. 4
u.h.f. bands	max. 5
reflection coefficient	
v.h.f. bands	max. 60%
u.h.f. bands	max. 66%
Output impedance (i.f.)	75 Ω approx.
Capacitance between terminals	typ. 3,5 pF
Load impedance	min. 1 k Ω //max. 22 pF total capacitance load to be tuned to 36,15 MHz by means of an inductance between terminals 16 and 17 (min.L:590 nH)
R.F. curves bandwidth	
low v.h.f. band	typ. 10 MHz
high v.h.f. band	typ. 10 MHz
u.h.f. bands	typ. 15 MHz

R.F. curves, tilt

on any channel the amplitude difference between the top of the r.f. resonant curve and the picture frequency, the sound frequency, or any frequency between them will not exceed 3 dB at nominal gain, and 4 dB in the a.g.c. range between nominal gain and 20 dB gain reduction.

A.G.C. range

v.h.f. bands
u.h.f. bands

min. 40 dB
min. 30 dB

Voltage gain

low v.h.f. band
high v.h.f. band
channels S2 to S6
channels S7 to S20
u.h.f. bands

min. 40 dB; max. 50 dB
typ. 36 dB; max. 46 dB
typ. 40 dB; max. 50 dB
min. 40 dB; max. 50 dB

Maximum gain difference

between any two v.h.f. channels
between any two u.h.f. channels
between any v.h.f. and u.h.f. channel

typ. 6 dB
typ. 6 dB
typ. 6 dB

Noise figure

v.h.f. bands
E channels
S channels
u.h.f. bands

typ. 5 dB; max. 8 dB
typ. 7 dB; max. 10 dB
typ. 8 dB; max. 11 dB

Overloading

Input signal producing 1 dB gain compression at nominal gain

v.h.f. bands
u.h.f. bands

typ. 90 dB (μV) into 75 Ω ; min. 85 dB (μV)
typ. 100 dB (μV) into 75 Ω ; min. 90 dB (μV)

Input signal producing either a detuning of the oscillator of + 300 kHz or -1000 kHz or stopping of the oscillations at nominal gain

v.h.f. bands
u.h.f. bands

typ. 110 dB (μV) into 75 Ω ; min. 100 dB (μV)
typ. 110 dB (μV) into 75 Ω ; min. 100 dB (μV)

Unwanted signal characteristics

Image rejection (measured at picture carrier frequency)

v.h.f. bands
u.h.f. bands

min. 66 dB; typ. 70 dB
min. 53 dB; typ. 60 dB

I.F. rejection (measured at picture carrier frequency)

low v.h.f. band	min. 60 dB
high v.h.f. band	min. 60 dB
u.h.f. bands	min. 60 dB

Note: At colour sub-carrier frequency maximum 6 dB less rejection.

Cross modulation

Input signal producing 1% cross modulation, i.e. 1% of the modulation depth of the interfering signal is transferred to the wanted signal.

In channel cross modulation (wanted signal: picture carrier frequency; interfering signal: sound carrier frequency)

v.h.f. bands

at nominal gain (wanted input level 60 dB (μ V))	typ. 80 dB (μ V) into 75 Ω
at 40 dB gain reduction (wanted input level 100 dB (μ V))	typ. 100 dB (μ V) into 75 Ω

u.h.f. bands

at nominal gain (wanted input level 60 dB (μ V))	typ. 80 dB (μ V) into 75 Ω
at 30 dB gain reduction (wanted input level 90 dB (μ V))	typ. 100 dB (μ V) into 75 Ω

In band cross modulation (wanted signal: picture carrier of channel N; interfering signal: picture carrier of channel $N \pm 2$ for low v.h.f., or channel $N \pm 3$ for high v.h.f., or channel $N \pm 5$ for u.h.f.)

v.h.f. bands

at nominal gain (wanted input level 60 dB (μ V))	typ. 95 dB (μ V) into 75 Ω
at 40 dB gain reduction (wanted input level 100 dB (μ V))	typ. 100 dB (μ V) into 75 Ω

u.h.f. bands

at nominal gain (wanted input level 60 dB (μ V))	typ. 94 dB (μ V) into 75 Ω
at 30 dB gain reduction (wanted input level 90 dB (μ V))	typ. 100 dB (μ V) into 75 Ω

Out of band cross modulation at nominal gain

low v.h.f., interfering from high v.h.f.	typ. 100 dB (μ V) into 75 Ω
low v.h.f., interfering from u.h.f.	typ. 100 dB (μ V) into 75 Ω
high v.h.f., interfering from low v.h.f.	typ. 100 dB (μ V) into 75 Ω
high v.h.f., interfering from u.h.f.	typ. 100 dB (μ V) into 75 Ω
u.h.f. interfering from low v.h.f.	typ. 100 dB (μ V) into 75 Ω
u.h.f. interfering from high v.h.f.	typ. 100 dB (μ V) into 75 Ω

Unwanted signal handling capability (visibility test)

For the channel combinations

v.h.f.: $N \pm 1$, $N \pm 5$, $N + 11$
u.h.f.: $N \pm 1$, $N \pm 5$, $N + 9$

The tuner meets the requirements of "Amtsblatt" DBP/1981, item 5.1.2., when measured in an adequate TV receiver. The a.g.c. circuit of the receiver has to be adjusted with an input signal of 74 dB (μ V) on channel E60 in such a way, that the gain of the tuner is decreased by 10 dB.

Oscillator characteristics

Pulling

Input signal of tuned frequency producing a shift of the oscillator frequency of 10 kHz, at nominal gain

v.h.f. bands

typ. 86 dB (μ V) into 75 Ω

u.h.f. bands

typ. 86 dB (μ V) into 75 Ω

Shift of oscillator frequency at a change of the supply voltage of 5%

v.h.f. bands

max. 250 kHz

u.h.f. bands

max. 500 kHz

Drift of oscillator frequency

during warm-up time (after the tuner has been completely out of operation for 15 min, measured between 5 s and 15 min after switching on)

max. 250 kHz

during warm-up time (after the input stage is in operation for 15 min, measured between 2 s and 15 min after band switching)

max. 250 kHz

at a change of the ambient temperature from + 25 to + 40 °C (measured after 3 cycles from + 25 to + 55 °C)

v.h.f. bands

max. 500 kHz

u.h.f. bands

max. 500 kHz

at a change of humidity from 60 \pm 15% to 93 \pm 2%, at $T_{amb} = 25 \pm 5$ °C

low v.h.f. band

max. 500 kHz

high v.h.f. band

max. 1000 kHz

u.h.f. bands

max. 1500 kHz

Frequency divider characteristics of the UV618/256

Division ratio	256
Supply voltage	+ 5 V \pm 5%
Current drawn from + 5 V supply	max. 35 mA; typ. 25 mA
Output voltage, unloaded, measured with probe 10 M Ω /11 pF	min. 0,3 V p-p
Output impedance	typ. 1 k Ω
Output imbalance	typ. 0,1 V
Interference signal on the i.f. output	max. 30 dB (μ V)

Note: I.F. output of the tuner terminated with 10 M Ω /11 pF

Miscellaneous

Radio interference
Oscillator radiation and oscillator
voltage at the aerial terminal

Within the limits of C.I.S.P.R. 13
(1975), VDE0872/7.72. and
Amtsblatt DBP69/1981, when
applying the tuner in an adequate
TV receiver

Microphonics

There will be no microphonics,
provided the tuner is installed
in a professional manner.

Surge protection

Protection against voltages

max. 5 kV

Note: 10 discharges of a 470 pF capacitor into the aerial terminal.

Protection against flashes

max. 30 kV, 400 mWs

Note: A flashover circuit producing flashes with frequencies of 1 to 20 Hz for 30 s is connected to the aerial terminal.

ADDITIONAL INFORMATION**I.F. injection**

An i.f. signal from a generator (internal resistance 50 Ω or 75 Ω) should be connected to the i.f. injection point TP1, accessible through a hole in the cover (see Fig. 2) via a probe (see Fig. 5).

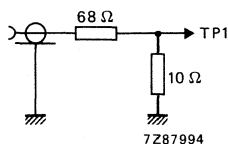

Fig. 5.

DEVELOPMENT DATA

This data sheet contains advance information and specifications are subject to change without notice.

UV627
UV628/256

V.H.F./U.H.F. TELEVISION TUNERS

QUICK REFERENCE DATA

Systems	C.C.I.R. systems L and L'	
Channels	<u>off-air</u>	<u>cable</u>
low v.h.f.	02 to 04	
high v.h.f.	05 to 10	C to Q
u.h.f.	L21 to L69	
Intermediate frequencies		
picture	32,7 MHz	
sound	39,2 MHz	
(The oscillator frequency is higher than the aerial signal frequency in the low v.h.f. band and lower in all other bands).		

APPLICATION

Designed to cover all channels of C.C.I.R. systems L and L' including the cable channels C to Q for French cable television.

The i.f. output is designed for direct drive of a variety of SAW filters.

The tuner UV628/256 is equipped with a frequency divider, which makes it suitable for digital tuning systems based on frequency synthesis; for the remainder it is equal to type UV627.

Available versions

	aerial input connector	frequency divider (IC)	catalogue number
UV627	IEC	—	3111 267 10010
UV628/256	IEC	1 : 256	3111 237 10030

Both tuners comply with the requirements of radiation of C.I.S.P.R. 13 (1975) including amendment 1 (1983).

DESCRIPTION

The UV627 and UV628/256 are combined v.h.f./u.h.f. tuners with electronic tuning and band switching, covering the low v.h.f. band (frequency range 48 to 68 MHz), the high v.h.f. band (frequency range 128 to 304 MHz), and the u.h.f. band (frequency range 470 to 860 MHz).

Mechanically, the tuners are built on a low-loss printed-wiring board, carrying all components, in a die-cast metal housing made of a rectangular frame and front and rear covers (see Fig. 2). The common SNIR (9 mm) coaxial aerial connector (75Ω) is integrated in one of the frame sides of the housing, all other connections (supply voltages, a.g.c. voltage, tuning and switching voltages, i.f. output) are made via terminals in the underside. The mounting method is shown in Fig. 3.

Electrically, the tuners consist of v.h.f. and u.h.f. parts (see Fig. 1). They are equipped with a common aerial input and provided with tuned r.f. MOSFET input stages. The v.h.f. mixer, v.h.f. oscillator and i.f. amplifier functions are provided by a tuner IC. This IC has terminals between mixer and i.f. amplifier to connect i.f. preselections.

Output impedance of the symmetrical i.f. terminals is approx. 75Ω to insure sufficient triple transient suppression of the SAW filter.

The r.f. band pass filter and oscillator circuits of the v.h.f. part are tuned by 9 tuning diodes; band switching is achieved by 6 switching diodes.

The u.h.f. part of the tuner has a high-pass input circuit, followed by a single tuned circuit connected to gate 1 of an input MOSFET tetrode (with internal gate protection against surge). The drain load of this MOSFET tetrode is formed by a double tuned circuit transferring the r.f. signal to the Schottky barrier mixer diode. The i.f. signal from the mixer diode is amplified by the i.f. pre-amplifier of the tuner IC.

The r.f. band pass filter and oscillator circuits are tuned by 4 tuning diodes.

In all bands the tuner is gain-controlled via gate 2 of the input MOSFET tetrode.

A two-pole filter is used to comply with SCART 109 recommendation regarding i.f. selectivity.

A test point TP1 is provided for i.f. injection.

The electrical circuit of the UV628/256 is extended with a frequency divider (division ratio of 256), with an input connected to the v.h.f. and u.h.f. oscillators. The symmetrical ECL outputs are connected to terminals 13 and 14.

MECHANICAL DATA

Dimensions in mm

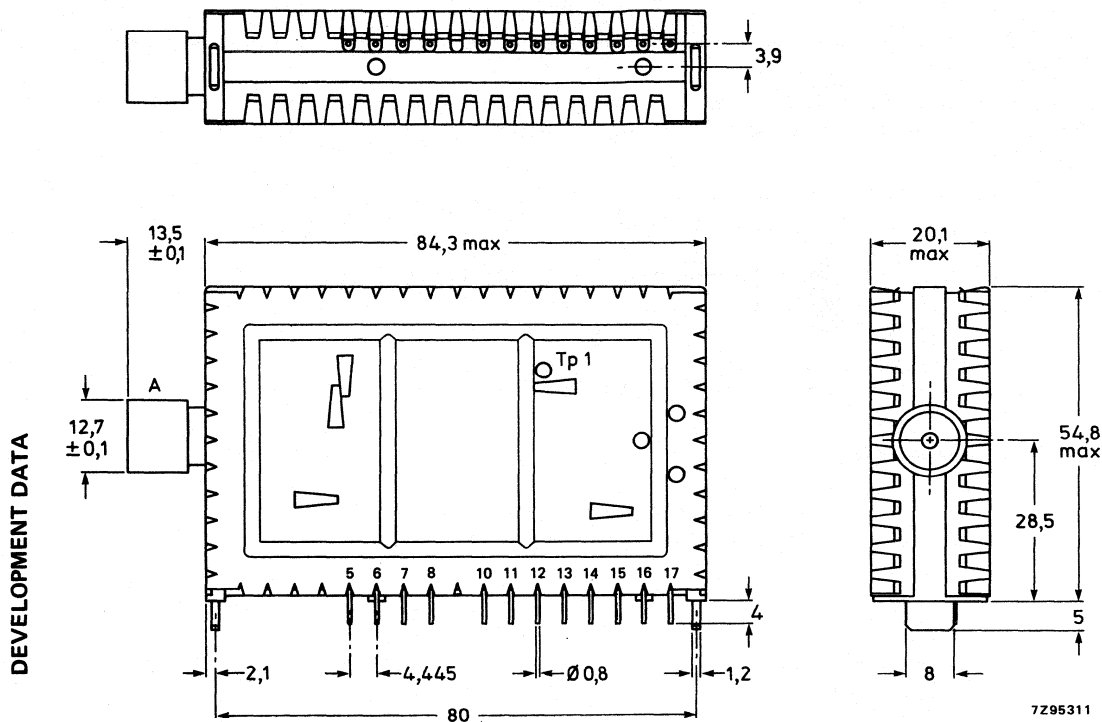

Unless otherwise stated the tolerance is ± 0,05 mm.

Fig. 2.

Terminal

- | | | |
|---|--|----------------------|
| A = aerial input, SNIR (9 mm) female 75 Ω | 12 = supply voltage, frequency divider, + 5 V | } only for UV628/256 |
| 5 = a.g.c. voltage, + 9,2 to 0,85 V | 13, 14 = balanced output voltage of frequency divider (1 kΩ) | |
| 6 = supply voltage, tuning part, + 12 V | 15 = earth | |
| 7 = supply voltage, low v.h.f., + 12 V | 16 = } i.f. output, symm. (approx. 75 Ω) | |
| 8 = supply voltage, high v.h.f., + 12 V | 17 = } | |
| 10 = supply voltage, u.h.f., + 12 V | | |
| 11 = tuning voltage, + 0,45 to + 30 V | | |

Mass approx. 95 g

Mounting

The tuner may be mounted by soldering it on to a printed-wiring board (using the piercing diagram shown in Fig. 3) without clearance between tuner supporting surface and board. The connection pins should be bent according to Fig. 4. The tuner may be mounted anywhere in the receiver and there are no restrictions on orientation.

The solderability of the terminals and mounting tabs is according to IEC 68-2, test Ta ($230 \pm 10 \text{ }^\circ\text{C}$, $2 \pm 0,5 \text{ s}$). The resistance to soldering heat is according to IEC 68-2, test Tb ($260 \pm 5 \text{ }^\circ\text{C}$, $10 \pm 1 \text{ s}$).

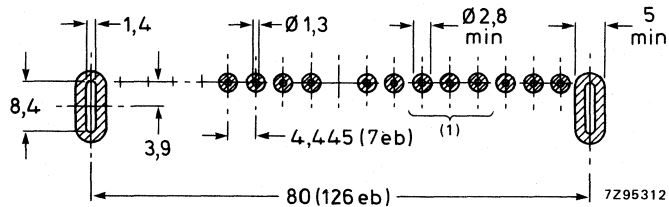

(1) Only for UV628/256

1 eb = 0,025 inch

Fig. 3 Piercing diagram viewed from solder side of board. Unless otherwise stated the tolerance is $\pm 0,05 \text{ mm}$.

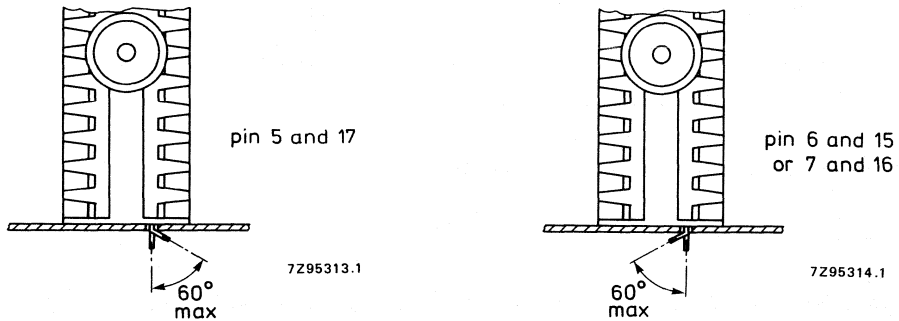

Fig. 4.

In order to prevent any stress to the printed-wiring board, the tuner should be supported at its aerial connector.

ELECTRICAL DATA

Unless otherwise specified all electrical values apply at an ambient temperature of 25 ± 5 °C, a relative humidity of $60 \pm 15\%$, a supply voltage of $12 \pm 0,3$ V and an a.g.c. voltage of $9,2 \pm 0,2$ V.

General

Semiconductors, v.h.f. bands

r.f. amplifier	BF992
mixer	TDA5030/C9
oscillator	
tuning diodes	6 x BB909B, 3 x OF643
switching diodes	6 x BA482

Semiconductors, u.h.f. bands

r.f. amplifier	BF996/S
oscillator	BF979
mixer	1SS99
tuning diodes	4 x OF643

Frequency divider

SP4653

Ambient temperature range

operating	-10 to + 60 °C
storage	-25 to + 85 °C

Relative humidity

max. 95%

Voltages and currents

Supply voltage	+ 12 V \pm 5%
Current drawn from + 12 V supply	max. 82 mA
Bandswitching	max. 20 mA

For operation in all bands the supply voltage is permanently connected to terminal 6. Additionally the supply voltage is connected to:

- terminal 7 for operation in low v.h.f. band
- terminal 8 for operation in high v.h.f. band
- terminal 10 for operation in u.h.f. bands

A.G.C. voltage

voltage range	+ 9,2 to + 0,85 V (max. 30 μ A)
voltage at nominal gain	+ 9,2 \pm 0,2 V
voltage at 40 dB gain reduction	
low v.h.f. band	typ. 2,5 V
high v.h.f. band	typ. 1,6 V
voltage at 30 dB gain reduction	
u.h.f. band	typ. 1,8 V

Note: A.G.C. voltage between 0 and + 10,5 V may be applied without risk of damage.

UV627 UV628/256

A.G.C. current	max. 30 μ A
Slope of a.g.c. characteristic at the end of the specified a.g.c. range	
v.h.f. band	typ. 40 dB/V
u.h.f. band	typ. 80 dB/V
Tuning voltage range	+ 0,6 to + 28 V
Current drawn from 28 V tuning voltage supply	
at $T_{amb} = 25\text{ }^{\circ}\text{C}$ and 60% R.H.	max. 1 μ A
at $T_{amb} = 25\text{ }^{\circ}\text{C}$ and 95% R.H.	max. 3 μ A
at $T_{amb} = 60\text{ }^{\circ}\text{C}$ and 60% R.H.	max. 3 μ A

Note: The source impedance of the tuning voltage offered to terminal 11 must be maximum 47 k Ω .

Slope of tuning characteristics	
low v.h.f. band, channel 02	typ. 4,1 MHz/V
channel 04	typ. 3,5 MHz/V
high v.h.f. band, channel C	typ. 15 MHz/V
channel Q	typ. 1,7 MHz/V
u.h.f. bands, channel 21	typ. 28,8 MHz/V
channel 69	typ. 3,6 MHz/V

Frequencies

Frequency ranges	
low v.h.f. band	channel 02 (picture carrier 55,75 MHz) to channel 04 (picture carrier 63,75 MHz). Margin at the low end: min. 2 MHz.
high v.h.f. band, off-air + cable	channel C (picture carrier 128,75 MHz) to channel Q (picture carrier 296,75 MHz). Margin at the low end: min. 0,75 MHz. Margin at the high end: min. 2 MHz.
u.h.f. bands	channel L21 (picture carrier 471,25 MHz) to channel L69 (picture carrier 855,25 MHz). Margin at the extreme channels: min. 3 MHz.
Intermediate frequencies	
picture	32,7 MHz
sound	39,2 MHz

The oscillator frequency is higher than the aerial signal frequency in the low v.h.f. band and lower in all other bands.

Wanted signal characteristics

Input impedance	75 Ω
V.S.W.R. and reflection coefficient (values between picture and sound carrier, as well as values at picture carrier)	
v.s.w.r.	<u>at nominal gain and during gain control</u>
v.h.f. bands	max. 4,4
u.h.f. bands	max. 4,4
reflection coefficient	
v.h.f. bands	max. 63%
u.h.f. bands	max. 63%

Output impedance (i.f.)	75 Ω approx.
Capacitance between terminals	typ. 3,5 pF
Load impedance	min. 1 k Ω //max. 22 pF total capacitance load to be tuned to 35,95 MHz by means of an inductance between terminals 16 and 17 (min. L:590 nH)
R.F. curves bandwidth	
low v.h.f. band	typ. 13 MHz
high v.h.f. band	typ. 13 MHz
u.h.f. bands	typ. 18 MHz
R.F. curves, tilt	on any channel the amplitude difference between the top of the r.f. resonant curve and the picture frequency, the sound frequency, or any frequency between them will not exceed 3 dB at nominal gain, at 4 dB in the a.g.c. range between nominal gain and 20 dB gain reduction.
A.G.C. range	
v.h.f. bands	min. 40 dB
u.h.f. bands	min. 30 dB
Voltage gain	
off-air channels	min. 40 dB; max. 50 dB
cable channels	min. 40 dB; max. 50 dB, channel C min. 38 dB
gain taper off-air channels	max. 6 dB
Noise figure	
v.h.f. bands, off-air	typ. 7 dB; max. 9 dB
v.h.f. band, cable	typ. 5 dB; max. 11 dB
u.h.f. bands	typ. 7,5 dB; max. 11 dB
Overloading	
Input signal producing 1 dB gain compression at nominal gain	
v.h.f. bands	t.b.f.
u.h.f. bands	t.b.f.
Input signal producing either a detuning of the oscillator of + 300 kHz or -1000 kHz or stopping of the oscillations at nominal gain	
v.h.f. bands	t.b.f.
u.h.f. bands	t.b.f.

Unwanted signal characteristics

Image rejection (measured at picture carrier frequency)

low v.h.f. band	min. 40 dB
high v.h.f. band	min. 60 dB
u.h.f. bands	min. 40 dB

I.F. rejection (measured at picture carrier frequency)

all bands, except low v.h.f. band (= min. 55 dB)	min. 60 dB
--	------------

Cross modulation

Input signal producing 1% cross modulation, i.e. 1% of the modulation depth of the interfering signal is transferred to the wanted signal.

In channel cross modulation (wanted signal: picture carrier frequency; interfering signal: sound carrier frequency)

v.h.f. bands

at nominal gain (wanted input level 60 dB (μ V))	min. 70 dB(μ V)
at 40 dB gain reduction (wanted input level 100 dB (μ V))	t.b.f.

u.h.f. bands

at nominal gain (wanted input level 60 dB (μ V))	min. 70 dB(μ V)
at 30 dB gain reduction (wanted input level 90 dB (μ V))	t.b.f.

In band cross modulation (wanted signal: picture carrier of channel N; interfering signal: picture carrier of channel $N \pm 2$ for low v.h.f., or channel $N \pm 3$ for high v.h.f., or channel $N \pm 5$ for u.h.f.).

v.h.f. bands

at nominal gain (wanted input level 60 dB (μ V))	t.b.f.
at 40 dB gain reduction (wanted input level 100 dB (μ V))	t.b.f.

u.h.f. bands

at nominal gain (wanted input level 60 dB (μ V))	t.b.f.
at 30 dB gain reduction (wanted input level 90 dB (μ V))	t.b.f.

Out of band cross modulation at nominal gain

each of the v.h.f. or u.h.f. bands interfering with any of the other bands mentioned	t.b.f.
---	--------

Oscillator characteristics

Oscillator voltage at aerial input

v.h.f. bands	max. 50 dB (μ V)
u.h.f. bands	max. 66 dB (μ V)

Oscillator voltage at the terminals

supply and control pins t.b.f.

i.f. terminals for:

v.h.f.	t.b.f.
u.h.f.	t.b.f.

Pulling

Input signal of tuned frequency producing a shift of the oscillator frequency of 10 kHz, at nominal gain

all bands	typ. 69 dB (μ V) into 75 Ω
-----------	--

Shift of oscillator frequency at a change of the supply voltage of 5%

v.h.f. bands	max. 500 kHz
u.h.f. bands	max. 700 kHz
during a.g.c.	max. 150 kHz

Drift of oscillator frequency

during warm-up time (after the tuner has been completely out of operation for 15 min, measured between 5 s and 15 min after switching on)	max. 300 kHz
---	--------------

during warm-up time (after the input stage is in operation for 15 min, measured between 2 s and 15 min after band switching)	max. 250 kHz
--	--------------

at a change of the ambient temperature from + 25 to + 40 °C (measured after 3 cycles from + 25 to 0 °C)

v.h.f. bands	t.b.f.
u.h.f. bands	t.b.f.

at a change of humidity from 60 ± 15% to 93 ± 2%, at $T_{amb} = 25 \pm 5$ °C

low v.h.f. band	500 kHz
high v.h.f. band	1000 kHz
u.h.f. bands	1500 kHz

DEVELOPMENT DATA

Frequency divider characteristics of the UV628/256

Division ratio	256
Supply voltage	+ 5 V ± 5%
Current drawn from + 5 V supply	max. 35 mA
Output voltage, unloaded, measured with probe 10 M Ω /11 pF	min. 0,5 V _{p-p}
Output impedance	typ. 1 k Ω
Output imbalance	max. 0,1 V
Interference signal on the i.f. output	max. 30 dB (μ V)

Note: I.F. output of the tuner terminated with 10 M Ω /11 pF.

Miscellaneous

Radio interference
Oscillator radiation and oscillator
voltage at the aerial terminal

Within the limits of C.I.S.P.R. 13
(1975), amendment 1 (1983),
when applying the tuner in an
adequate TV receiver

Microphonics

There will be no microphonics,
provided the tuner is installed
in a professional manner.

Surge protection
Protection against voltages

max. 5 kV

Note: 10 discharges of a 470 pF capacitor into the aerial terminal.

Protection against flashes

t.b.f.

Note: A flashover circuit producing flashes with frequencies of 1 to 20 Hz for 30 s is connected to the aerial terminal.

ADDITIONAL INFORMATION

I.F. injection

An i.f. signal from a generator (internal resistance 50Ω or 75Ω) should be connected to the i.f. injection point TP1, accessible through a hole in the cover (see Fig. 2) via a probe (see Fig. 5).

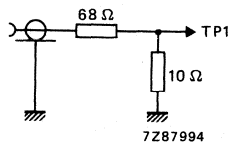

Fig. 5.

V.H.F./U.H.F. TELEVISION TUNERS

QUICK REFERENCE DATA

Systems	R.T.M.A. systems M and N	
	off-air	cable
Channels		
range a, low v.h.f. band	A2 to A6	
mid band		A-2 to A-1
range b, mid band		A to I
high v.h.f. band	A7 to A13	
super band		J to T
range c, super band		U to W
hyper band		AA to RR
range d, hyper band		SS to EEE
ultra band		65 and 66
u.h.f. band	A14 to A69	
Intermediate frequencies		
picture	45,75 MHz	
colour	42,17 MHz	
sound	41,25 MHz	

APPLICATION

Designed to cover the v.h.f. and u.h.f. channels of R.T.M.A. systems M and N with extended v.h.f. frequency ranges, including the mid band, super band, hyper band and ultra band CATV.

The i.f. output is designed for direct drive of a variety of SAW filters.

The tuner UV636/256 is equipped with a frequency divider, which makes it suitable for digital tuning systems based on frequency synthesis; for the remainder it is equal to type UV635.

Available versions

	aerial input connector	frequency divider (IC)	catalogue number
UV635	phono	—	t.b.f.
UV636/256	phono	1 : 256	3122 237 00230

Both tuners comply with the requirements of radiation, signal handling capability, and immunity from radiated interference of FCC.

UV635 UV636/256

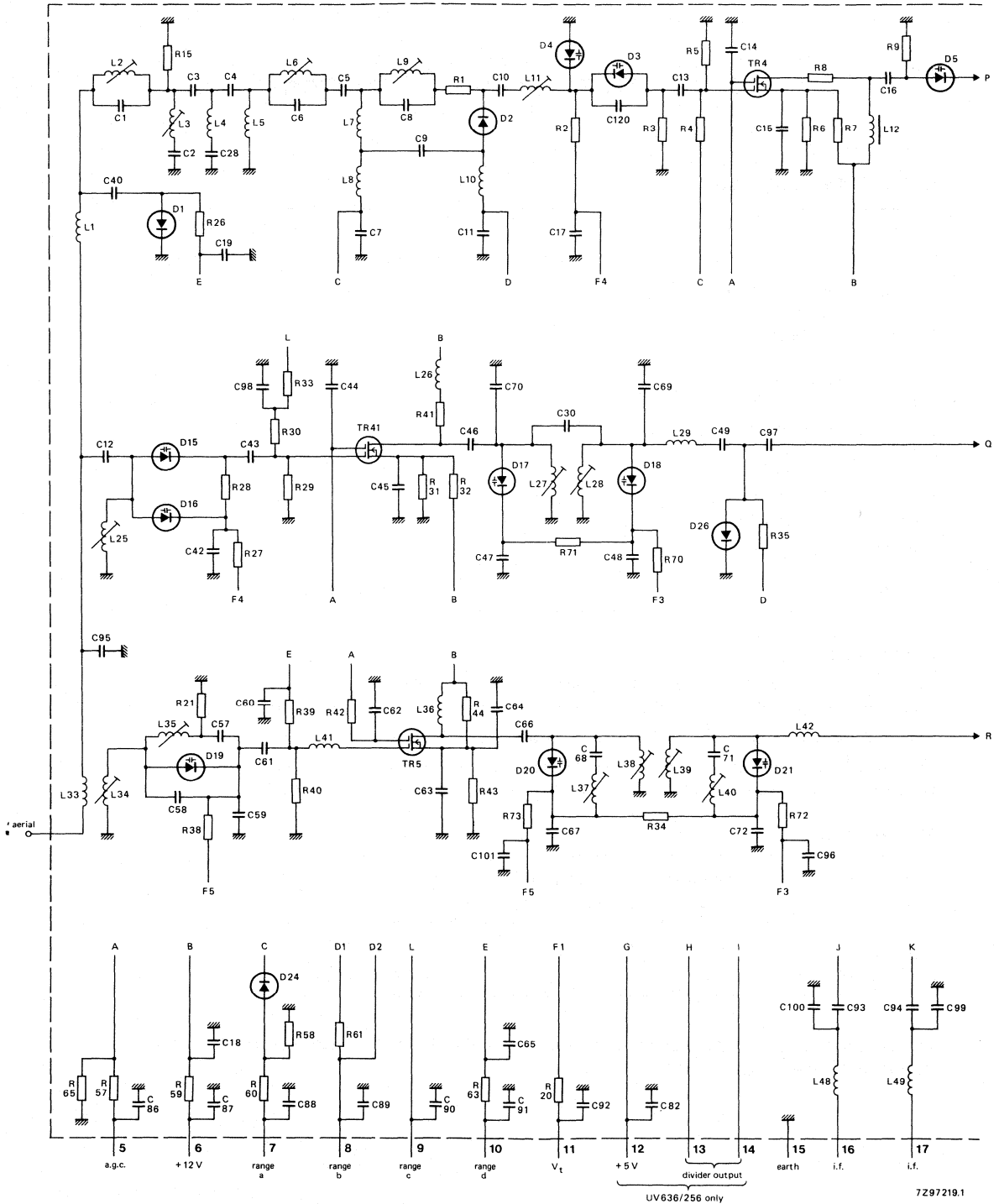

DEVELOPMENT DATA

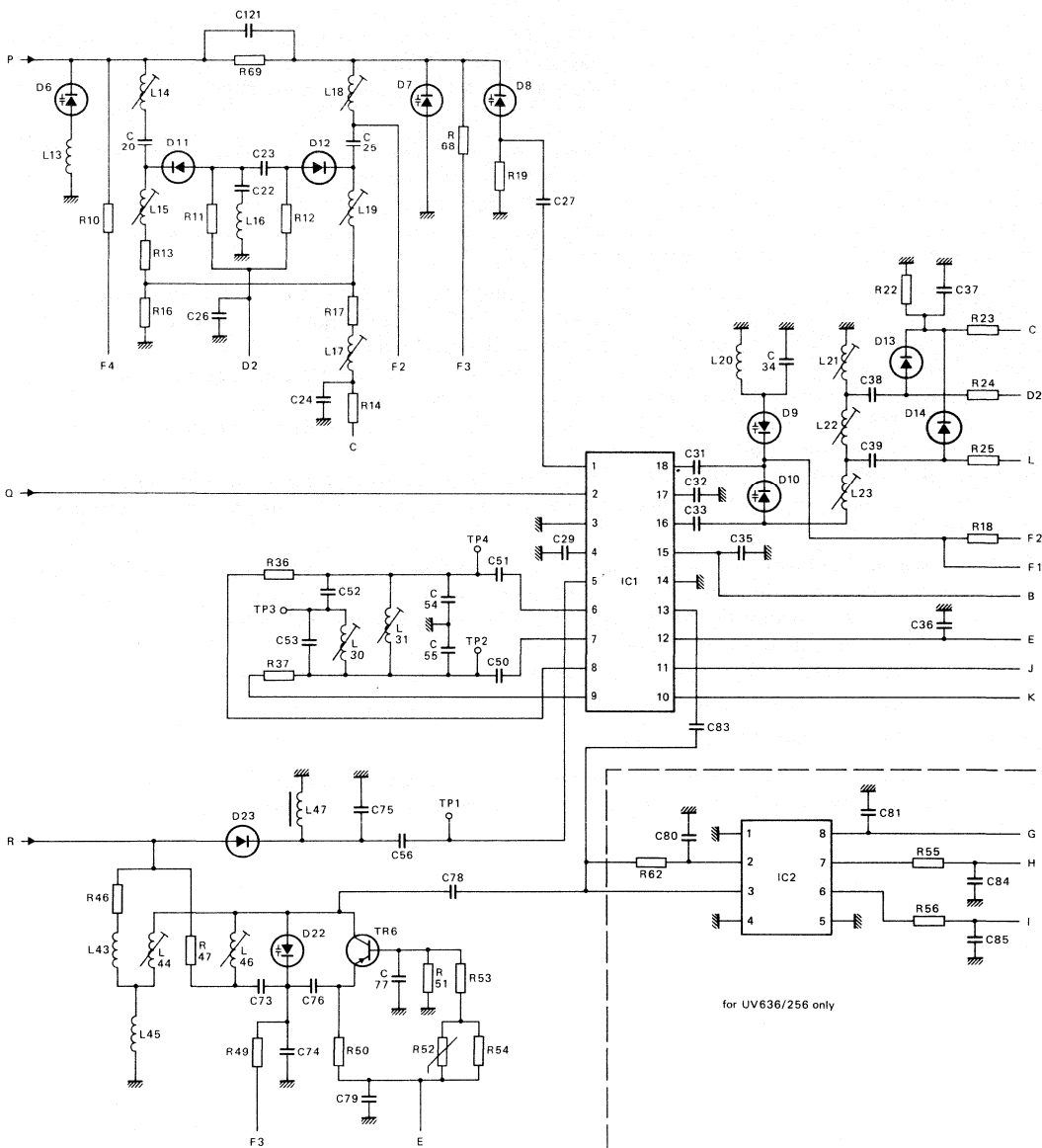

7297220.1

Fig. 1 Circuit diagram.

DESCRIPTION

The UV635 and UV636/256 are combined v.h.f./u.h.f. tuners with electronic tuning and band switching, covering a large frequency range in four parts: range a, from 55,25 MHz to 115,25 MHz; range b, from 121,25 to 277,25 MHz; range c, from 283,25 to 403,25 MHz; range d, from 409,25 to 801,25 MHz. See also under "Frequencies".

Mechanically, the tuners are built on a low-loss printed-wiring board, carrying all components, in a die-cast metal housing made of a rectangular frame and front and rear covers (see Fig. 2). The common phono coaxial aerial connector (75Ω) is situated on one of the frame sides of the housing, all other connections (supply voltages, a.g.c. voltage, tuning and switching voltages, i.f. output) are made via terminals in the underside. The mounting method is shown in Fig. 3.

Electrically, the tuners consist of v.h.f., hyperband and u.h.f. parts (see Fig. 1). They are equipped with a common aerial input and provided with tuned r.f. MOSFET input stages. The mixer and oscillator for the ranges a, b and c, and i.f. amplifier functions are provided by a tuner IC. This IC has terminals between mixer and i.f. amplifier to connect i.f. preselections, a 47,25 MHz trap is provided to improve the selectivity of common SAW filters for adjacent channel N - 1 (system B).

Output impedance of the symmetrical i.f. terminals is approx. 75Ω to insure sufficient triple transient suppression of the SAW filter.

The r.f. band pass filter and oscillator circuits of the v.h.f. part are tuned by 5 tuning diodes; band switching is achieved by 5 switching diodes, those of the hyperband by 4 tuning diodes and 3 switching diodes respectively.

The u.h.f. part of the tuner has a tuned input circuit connected to gate 1 of an input MOSFET tetrode (with internal gate protection against surge). The drain load of this MOSFET tetrode is formed by a double tuned circuit transferring the r.f. signal to the Schottky barrier mixer diode. The i.f. signal from the mixer diode is amplified by the i.f. pre-amplifier of the tuner I.C.

The r.f. band pass filter and oscillator circuits are tuned by 4 tuning diodes.

In all bands the tuner is gain-controlled via gate 2 of the input MOSFET tetrode.

A test point TP1 is provided for i.f. injection.

The electrical circuit of the UV636/256 is extended with a frequency divider (division ratio of 256), with an input connected to both oscillators. The symmetrical ECL outputs are connected to terminals 13 and 14.

MECHANICAL DATA

Dimensions in mm

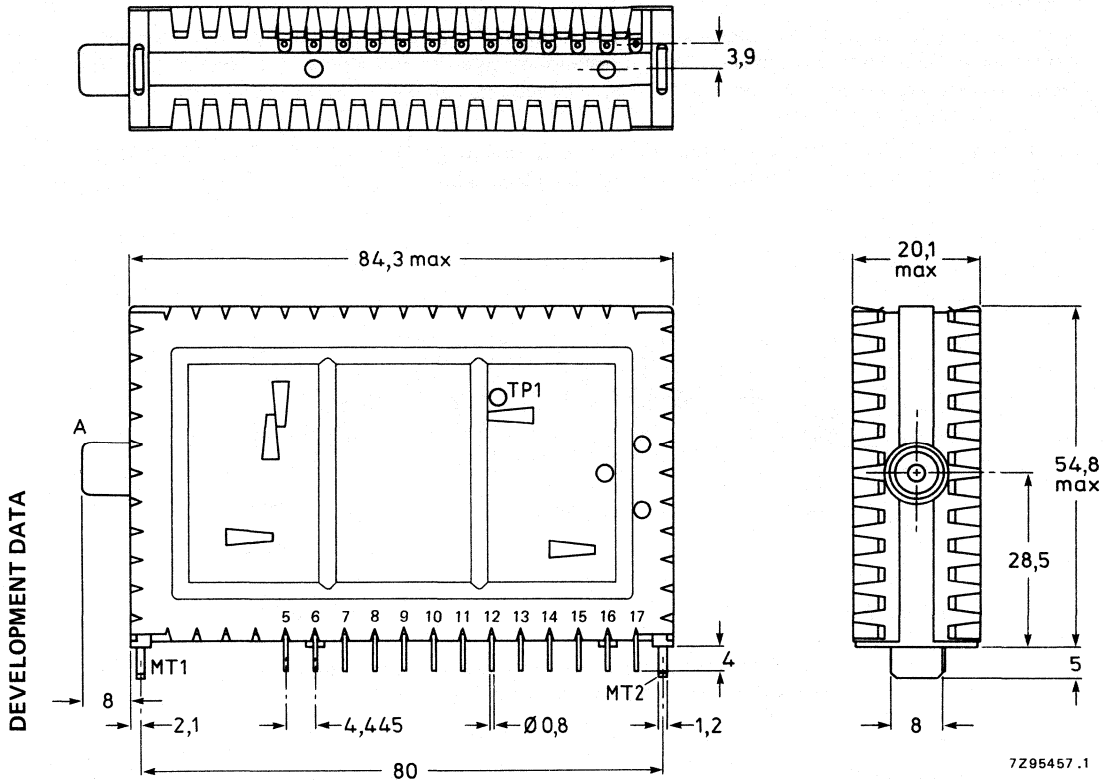

Unless otherwise stated the tolerance is $\pm 0,05$ mm.

Fig. 2.

Terminal

- A = aerial input (phono 75Ω)
- 5 = a.g.c. voltage, + 9,2 to + 0,85 V
- 6 = supply voltage, tuning part, + 12 V
- 7 = supply voltage, range a, + 12 V
- 8 = supply voltage, range b, + 12 V
- 9 = supply voltage, range c, + 12 V
- 10 = supply voltage, range d, + 12 V
- 11 = tuning voltage, + 0,8 to + 28 V

- 12 = supply voltage, frequency divider, + 5 V
- 13,14 = balanced output voltage of frequency divider (1 k Ω)
- 15 = earth
- 16 = } i.f. output, symm. (approx. $46 + j70 \Omega$)
- 17 = }

only for
UV636/256

MT1, MT2 = mounting tabs (to be earthed)

Mass 99 g

Mounting

The tuner may be mounted by soldering it on to a printed-wiring board (using the piercing diagram shown in Fig. 3) without clearance between tuner supporting surface and board. The connection pins should be bent according to Fig. 4. The tuner may be mounted anywhere in the receiver and there are no restrictions on orientation.

The solderability of the terminals and mounting tabs is according to IEC 68-2, test Ta ($230 \pm 10 \text{ }^\circ\text{C}$, $2 \pm 0,5 \text{ s}$). The resistance to soldering heat is according to IEC 68-2, test Tb ($260 \pm 5 \text{ }^\circ\text{C}$, $10 \pm 1 \text{ s}$).

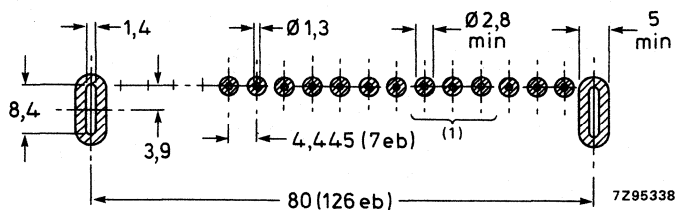

(1) Only for UV636/256

1 eb = 0,025 inch

Fig. 3 Piercing diagram viewed from solder side of board. Unless otherwise stated the tolerance is $\pm 0,05 \text{ mm}$.

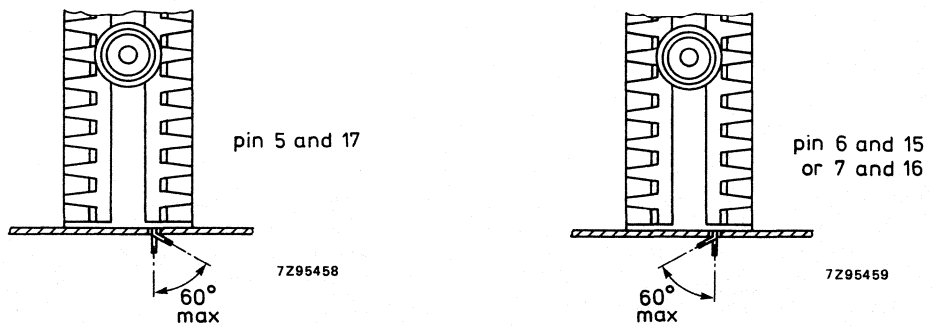

Fig. 4.

In order to prevent any stress to the printed-wiring board, the tuner should be supported at its aerial connector.

ELECTRICAL DATA

Unless otherwise specified all electrical values apply at an ambient temperature of 25 ± 5 °C, a relative humidity of $60 \pm 15\%$, a supply voltage of $12 \pm 0,3$ V and an a.g.c. voltage of $9,2 \pm 0,2$ V.

General

Semiconductors, ranges a and b

r.f. amplifier	BF992
mixer	TDA5030
oscillator	
tuning diodes	4 x OF633
switching diodes	4 x BA482/483/484
coupling diodes	BB809 and BB809B
d.c. blocking diodes	2 x BAS15

Semiconductors, range c

r.f. amplifier	BF990
oscillator	TDA5030
mixer	
tuning diodes	4 x OF633
switching diodes	2 x BA482
coupling diode	BB909B

Semiconductors, range d

r.f. amplifier	BF990
oscillator	BF970
mixer	1SS99
tuning diodes	4 x OF643

Frequency divider

SP4653

Ambient temperature range

operating	-10 to +60 °C
storage	-25 to +85 °C

Relative humidity

max. 95%

Voltages and currents

Supply voltage	+ 12 V \pm 10%
Current drawn from + 12 V supply	max. 60 mA
Bandswitching	max. 15 mA

For operation in all bands the supply voltage is permanently connected to terminal 6. Additionally the supply voltage is connected to:

- terminal 7 for operation in range a
- terminal 8 for operation in range b
- terminal 9 for operation in range c
- terminal 10 for operation in range d

A.G.C. voltage	
voltage range	+ 9,2 to 0,85 V
voltage at nominal gain	+ 9,2 ± 0,5 V
voltage at 45 dB gain reduction	
ranges a and b	typ. 3 V
voltage at 30 dB gain reduction	
range c	typ. 2 V
range d	typ. 2 V

Note: A.G.C. voltage between 0 and + 10,5 V may be applied without risk of damage.

A.G.C. current	max. 30 µA
----------------	------------

Slope of a.g.c. characteristic
at the end of the specified a.g.c. range

range a	typ. 40 dB/V
ranges b and c	typ. 70 dB/V
range d	typ. 80 dB/V

A.G.C. time constant	max. 8 ms
----------------------	-----------

A.G.C. source impedance	max. 10 kΩ
-------------------------	------------

Tuning voltage range	+ 0,8 to + 28 V
----------------------	-----------------

Current drawn from 28 V tuning voltage supply

at $T_{amb} = 25\text{ °C}$ and 60% R.H.	max. 0,5 µA
at $T_{amb} = 25\text{ °C}$ and 95% R.H.	max. 2 µA
at $T_{amb} = 60\text{ °C}$ and 60% R.H.	max. 2 µA

Note: The source impedance of the tuning voltage offered to terminal 11 must be maximum 47 kΩ.

Slope of tuning characteristic

range a	1 to 6 MHz/V
range b	2 to 14 MHz/V
range c	3 to 20 MHz/V
range d	4 to 25 MHz/V

The tuner has a built-in current limitation ($\leq 100\text{ }\mu\text{A}$ per varicap diode) for tuning voltages up to + 35 V, which can be applied during search tuning.

Frequencies

Frequency ranges, picture carrier

Off-air

low v.h.f. band	channel A2 (55,25 MHz) to channel A6 (83,25 MHz). Margin at the extreme channels: min. 2 MHz.
high v.h.f. band	channel A7 (175,25 MHz) to channel A13 (211,25 MHz). Margin at the extreme channels: min. 2 MHz.
u.h.f. band	channel A14 (471,25 MHz) to channel A69 (801,25 MHz). Margin at the extreme channels: min. 3 MHz.

Cable (CATV)	
mid band	channel A-2 (109,25 MHz) to channel I (169,25 MHz) Margin at the extreme channels: min. 3 MHz.
superband	channel J (217,25 MHz) to channel W (295,25 MHz) Margin at the extreme channels: min. 3 MHz.
hyperband	channel AA (301,75 MHz) to channel EEE (463,25 MHz). Margin at the extreme channels: min. 3 MHz.
ultra band	channel 65 (469,25 MHz) and channel 66 (475,25 MHz) Margin at the extreme channels: min. 3 MHz.
Intermediate frequencies	
picture	45,75 MHz
colour	42,17 MHz
sound	41,25 MHz
The oscillator frequency is higher than the aerial signal frequency.	
DEVELOPMENT DATA	
Wanted signal characteristics	
Input impedance	75 Ω
V.S.W.R. and reflection coefficient (values between picture and sound carrier, as well as values at picture carrier)	
v.s.w.r.	<u>at nominal gain and during gain control</u>
ranges a and b	max. 4
range c	max. 4
range d	max. 5
reflection coefficient	
ranges a and b	max. 60%
range c	max. 60%
range d	max. 66%
Output impedance (i.f.)	46 + j70 Ω
Capacitance between terminals	typ. 3,5 pF
Load impedance	min. 1 k Ω in parallel with max. 22 pF total capacitance load to be tuned to 43,5 MHz by means of an inductance between terminals 16 and 17 (min. L: 610 nH)
R.F. curves bandwidth	
range a	typ. 10 MHz
range b	typ. 13 MHz
range c	typ. 9 MHz
range d	typ. 14 MHz

Overall response, tilt	on any channel the amplitude difference between the top of the r.f. resonant curve and the picture frequency will not exceed 3 dB, between the top of the r.f. resonant curve and the sound frequency 5 dB at nominal gain, and in the a.g.c. range between nominal gain and 20 dB gain reduction.
A.G.C. range	
ranges a and b	min. 45 dB
range c	min. 30 dB
range d	min. 30 dB
Voltage gain	min. 40 dB, max. 50 dB
Maximum gain difference	
between any two v.h.f. channels	typ. 6 dB
between any two u.h.f. channels	typ. 6 dB
between any v.h.f. and u.h.f. channel	typ. 6 dB
Noise figure	
ranges a and b	max. 8 dB, typ. 6 dB
range c	max. 10 dB, typ. 6,5 dB
range d	max. 10 dB, typ. 8,5 dB
Overloading	
Input signal producing 1 dB gain compression at nominal gain	
ranges a and b	min. 100 dB (μ V) into 75 Ω
ranges c and d	min. 90 dB (μ V) into 75 Ω
Input signal producing either a detuning of the oscillator of + 300 kHz or -1000 kHz or stopping of the oscillations at nominal gain	
ranges a and b	min. 100 dB (μ V) into 75 Ω
ranges c and d	min. 90 dB (μ V) into 75 Ω
Unwanted signal characteristics	
Image rejection (measured at picture carrier frequency)	
ranges a and b	min. 60 dB, typ. 70 dB
range c	min. 60 dB, typ. 65 dB
range d	min. 45 dB, typ. 55 dB
I.F. rejection (measured at picture carrier frequency)	
all bands	min. 60 dB

Note: At colour sub-carrier frequency maximum 6 dB less rejection.

FM rejection

at channel A6 (90,5 MHz, aerial input level 60 dB (μV))	min. 50 dB
at channel A6 (93 to 100 MHz, aerial input level 90 dB (μV))	min. 50 dB

Cross modulation

An undesired carrier level producing 1% cross modulation on the desired carrier will be equal to or exceeds the desired carrier level for all gain values between nominal gain and 20 dB gain reduction or will be:

in channel cross modulation (wanted signal: picture carrier frequency; interfering signal: sound carrier frequency)

ranges a, b, c and d	min. 70 dB (μV) into 75 Ω
----------------------	---

in band cross modulation (wanted signal: picture carrier of channel N; interfering signal: picture carrier of channel N \pm 2)

ranges a, b and c	min. 78 dB (μV) into 75 Ω
-------------------	---

in band cross modulation (wanted signal: picture carrier of channel N; interfering signal: picture carrier of channel N \pm 5)

range d	min. 84 dB (μV) into 75 Ω
---------	---

Oscillator characteristics

Pulling

Input signal of tuned frequency producing a shift of the oscillator frequency of 10 kHz, at nominal gain
all bands

min. 74 dB (μV) into 75 Ω

Shift of oscillator frequency at a change of the supply voltage of 5%

ranges a and b	max. 250 kHz
range c	max. 500 kHz
range d	max. 500 kHz
during a.g.c., all ranges	max. 150 kHz

Drift of oscillator frequency

during warm-up time (after the tuner has been completely out of operation for 15 min, measured between 5 s and 15 min after switching on)

max. 250 kHz

during warm-up time (after the input stage is in operation for 15 min, measured between 2 s and 15 min after band switching)

max. 250 kHz

at a change of the ambient temperature from + 25 to + 50 $^{\circ}\text{C}$ (measured after 3 cycles from + 25 to 0 $^{\circ}\text{C}$)

ranges a, b and c	max. 500 kHz
range d	max. 1000 kHz

at a change of humidity from $60 \pm 15\%$
to $93 \pm 2\%$, at $T_{amb} = 25 \pm 5^\circ\text{C}$

range a
range b
range c
range d

max. 500 kHz
max. 1000 kHz
max. 1500 kHz
max. 1500 kHz

Frequency divider characteristics of the UV636/256

Division ratio	256
Supply voltage	+ 5 V \pm 10%
Current drawn from + 5 V supply	max. 35 mA
Output voltage, unloaded, measured with probe $10\text{ M}\Omega$ in parallel with 11 pF	min. 0,5 V (p-p)
Output impedance	typ. $1\text{ k}\Omega$
Output imbalance	max. 0,1 V
Interference signal on the i.f. output	max. 30 dB (μV)

Note: I.F. output of the tuner terminated with $10\text{ M}\Omega$ in parallel with 11 pF

Miscellaneous

Microphonics

There will be no microphonics,
provided the tuner is installed
in a professional manner.

Surge protection

Protection against voltages

max. 5 kV

Note: 10 discharges of a 470 pF capacitor into the aerial terminal.

Protection against flashes

max. 30 kV, 400 mWs

Note: A flashover circuit producing flashes with frequencies of 1 to 20 Hz for 30 s is connected to the aerial terminal.

ADDITIONAL INFORMATION

I.F. injection

An i.f. signal from a generator (internal resistance $50\ \Omega$ or $75\ \Omega$) should be connected to the i.f. injection point TP1, accessible through a hole in the cover (see Fig. 2) via a probe (see Fig. 5).

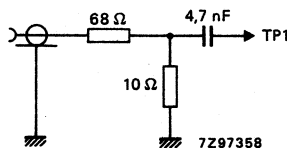

Fig. 5.

V.H.F./U.H.F. TELEVISION TUNERS

QUICK REFERENCE DATA

Systems	C.C.I.R. systems L and L'
Channels	
v.h.f. I	A to E4, including A to C
v.h.f. III	M4 to E12, including 1 to 6
u.h.f.	E21 to E69
Intermediate frequencies	
picture	32,7 MHz
sound	39,2 MHz

APPLICATION

Designed to cover the v.h.f. and u.h.f. channels of C.C.I.R. systems L and L'.

The tuner UVF10A is equipped with a frequency divider (1 : 256), which makes it suitable for digital tuning systems based on frequency synthesis; otherwise this tuner is equal to type UVF10.

DESCRIPTION

The UVF10 is a combined v.h.f./u.h.f. tuner with electronic tuning and band switching covering the v.h.f. band I including the European channel E4 (frequency range 41 to 68 MHz), the v.h.f. band III including the Moroccan channel M4 and the European channel E12 (frequency range 162 to 230 MHz) and the u.h.f. band (frequency range 470 to 861 MHz).

Mechanically, the tuner is built on a low-loss printed-wiring board, carrying all components, in a metal housing made of a rectangular frame and front and rear covers (see Fig. 2). The common aerial connection (v.h.f. and u.h.f.) with standard coaxial termination is on one of the frame sides, all other connections (supply voltages, a.g.c. voltage, tuning and switching voltages, i.f. output) are made via terminals in the underside. The mounting method is shown in Fig. 3.

Electrically, the tuner consists of v.h.f. and u.h.f. parts. The v.h.f. aerial signal is fed via switchable v.h.f. band I/III wideband input filters to gate 1 of an input MOSFET tetrode (with internal gate protection against surge).

The drain load of the MOSFET tetrode is formed by a double tuned switchable bandpass filter, transferring the r.f. signal to the emitter of the mixer transistor. The oscillator signal is also fed to the emitter of the mixer transistor.

The collector circuit of the mixer transistor is a single tuned i.f. resonant circuit, at the low end of which the i.f. signal is coupled out of the tuner. A test point (terminal 4) is provided for i.f. injection to align the output circuit of the tuner together with the i.f. amplifier of the television receiver.

The input tuned circuit, the r.f. bandpass filter and oscillator circuit are tuned by 4 tuning diodes, band switching is achieved by 8 switching diodes.

The u.h.f. part of the tuner consists of a tuned input circuit connected to gate 1 of an input MOSFET tetrode (with internal gate protection against surge). The drain load of this MOSFET tetrode is formed by a double tuned circuit transferring the r.f. signal to the Schottky barrier mixer diode. The i.f. signal from the mixer diode is amplified by the v.h.f. mixer transistor, now operating as an i.f. amplifier.

The input tuned circuit, the r.f. bandpass filter and oscillator circuits are tuned by 4 tuning diodes.

In all bands the tuner is gain controlled via gate 2 of the input MOSFET tetrodes.

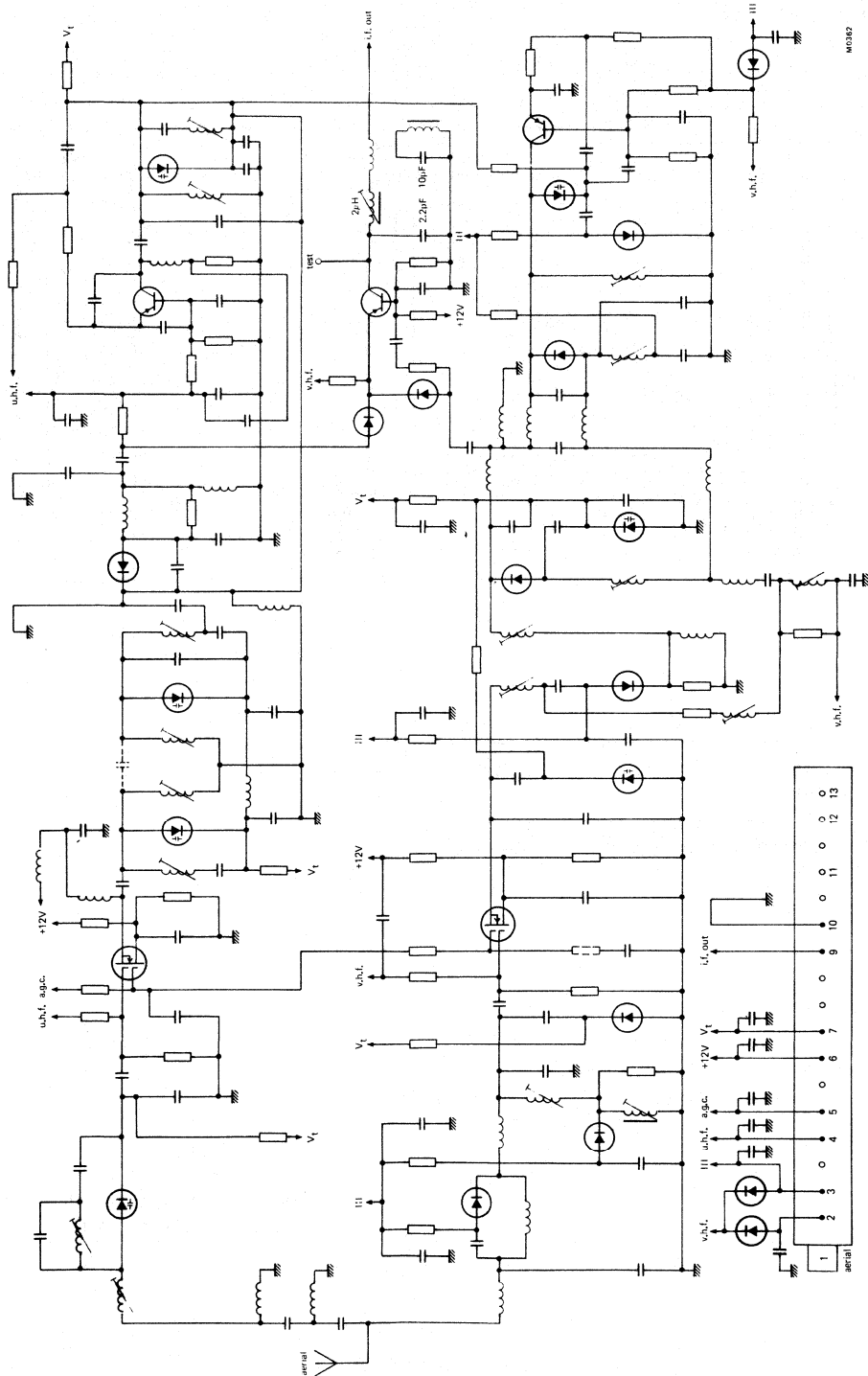
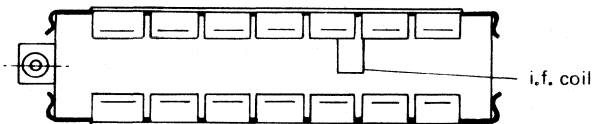
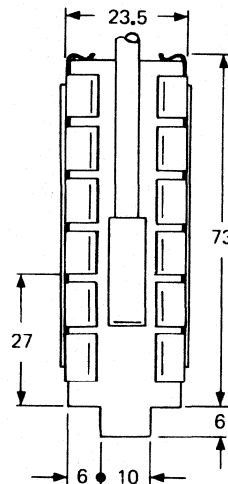
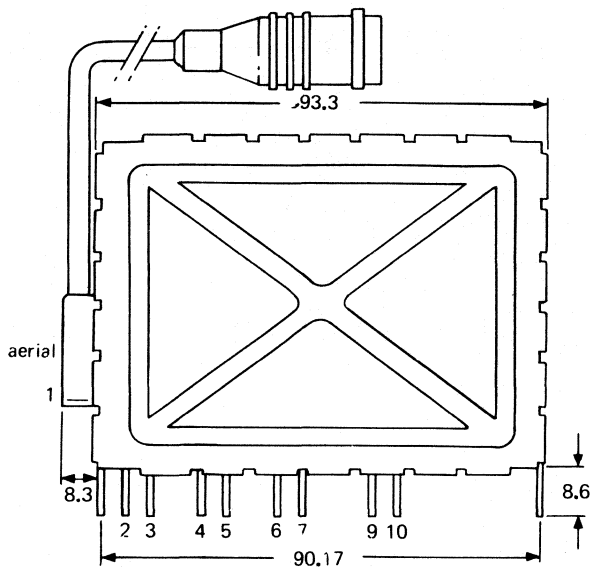

Fig. 1 Circuit diagram of tuner UVF10.

UVF10
UVF10A

MECHANICAL DATA

Dimensions in mm



M0363

Fig. 2a. UVF10.

- Terminal
- 1 = aerial
 - 2 = supply voltage, v.h.f. I, +12 V
 - 3 = supply voltage, v.h.f. III, +12 V
 - 4 = supply voltage, u.h.f., +12 V; i.f. injection
 - 5 = a.g.c. voltage, +8,25 to +0,85 V
 - 6 = supply voltage, v.h.f. and u.h.f., +12 V
 - 7 = tuning voltage, +0,5 to +28 V
 - 9 = i.f. output
 - 10 = earth

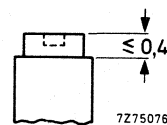

Fig. 2b I.F. output coil.
Torque for alignment: 2 to 15 mNm
Press-through force: ≥ 10 N.

Mass approx. 130 g

Mounting

The tuner may be mounted by soldering it onto a printed-wiring board, using the piercing diagram shown in Fig. 3. (The tuner may also be mounted by means of a socket. Information will be supplied upon request.) The tuner may be mounted anywhere in the receiver and there are no restrictions on orientation.

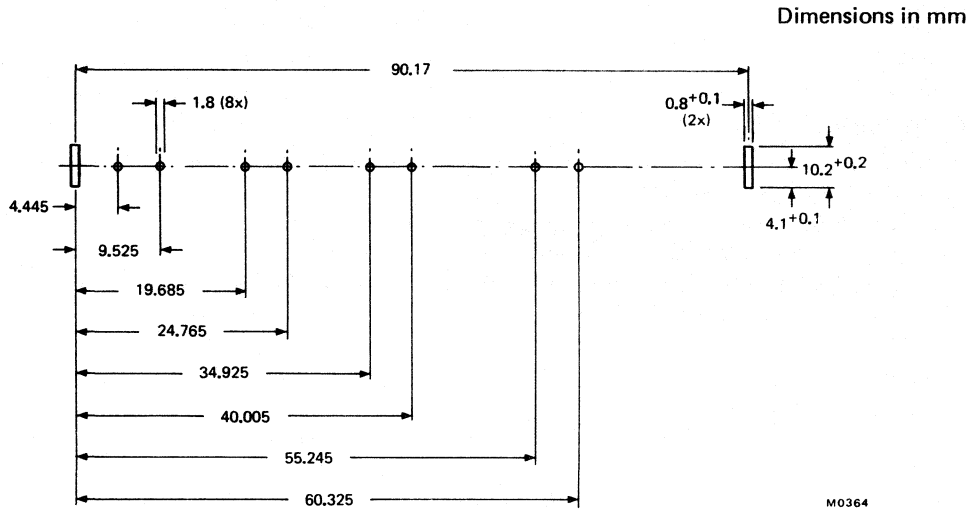

Fig. 3 Piercing diagram for tuner UVF10 viewed from solder side of board. Unless otherwise stated the tolerance is $\pm 0,05$ mm.

ELECTRICAL DATA

Unless otherwise specified all electrical values apply at an ambient temperature of 25 ± 5 °C, a relative humidity of $60 \pm 15\%$, a supply voltage of $12 \pm 0,3$ V and an a.g.c. voltage of $8,25 \pm 0,2$ V.

Voltages and currents

Supply voltage	+ 12 V \pm 1 V
Current drawn from + 12 V supply	
band I	max. 45 mA; typ. 40 mA
band III	max. 60 mA; typ. 55 mA
bands IV and V	max. 50 mA; typ. 45 mA

Bandswitching

For operation in all bands the supply voltage is permanently connected to terminal 6. Additionally the supply voltage is connected to:

- terminal 2 and -12 V to terminal 3 for operation in band I
- terminal 3 and -12 V to terminal 2 for operation in band II
- terminal 4 and -12 V to terminals 2 and 3 for operation in bands IV and V.

A.G.C. voltage (Figs 4, 5 and 6)

voltage range	+ 8,25 to + 0,85 V
voltage at nominal gain	+ 8,25 \pm 0,5 V
voltage at 40 dB gain reduction	
band I	typ. 2 V
band III	typ. 1,2 V

Note: A.G.C. voltages between 0 and + 10,5 V may be applied without risk or damage.

A.G.C. current	max. 0,3 μ A
Tuning voltage range (Figs 7, 8 and 9)	+ 0,5 to + 28 V
Current drawn from 28 V tuning voltage supply	
at $T_{amb} = 25$ °C	max. 0,5 μ A
at $T_{amb} = 55$ °C	max. 2 μ A

Slope of tuning characteristics (typical values)

band I, channel A	2 MHz/V
band I, channel C	0,8 MHz/V
band III, channel 1	4,5 MHz/V
band III, channel 6	2,5 MHz/V
bands IV and V, channel 21	30 MHz/V
bands IV and V, channel 69	6 MHz/V

Frequencies

Frequency ranges	
band I	channel A (picture carrier 47,75 MHz) Margin: min. tuning voltage 0,5 V channel E4 (picture carrier 62,25 MHz) Margin: min. 800 kHz

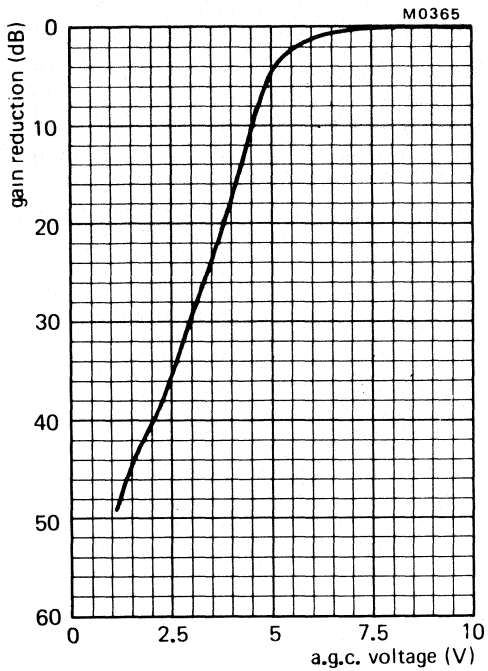

Fig. 4 Typical a.g.c. characteristic, band I.

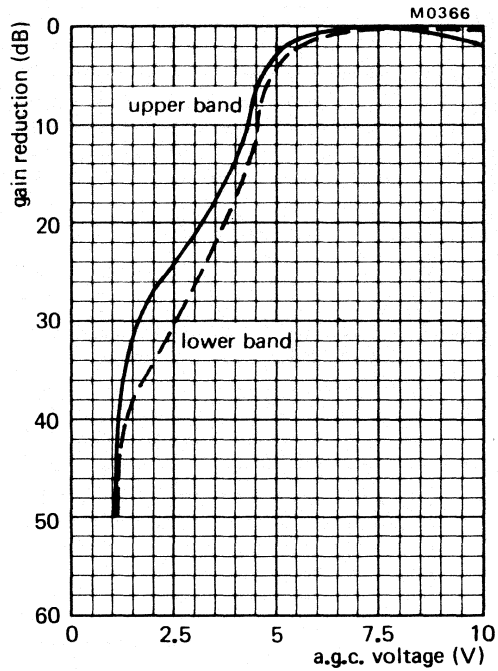

Fig. 5 Typical a.g.c. characteristic, band III.

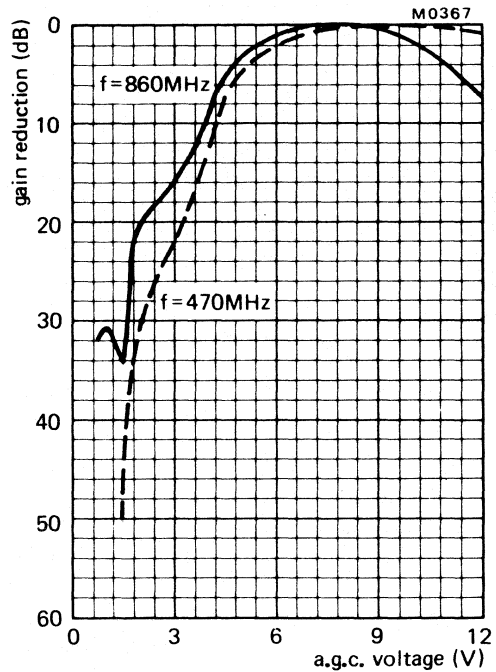

Fig. 6 Typical a.g.c. characteristic, bands IV and V.

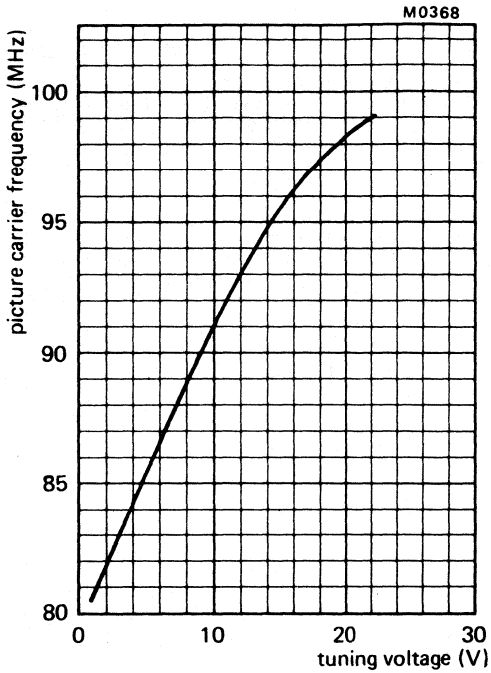

Fig. 7 Typical tuning characteristic, band I.

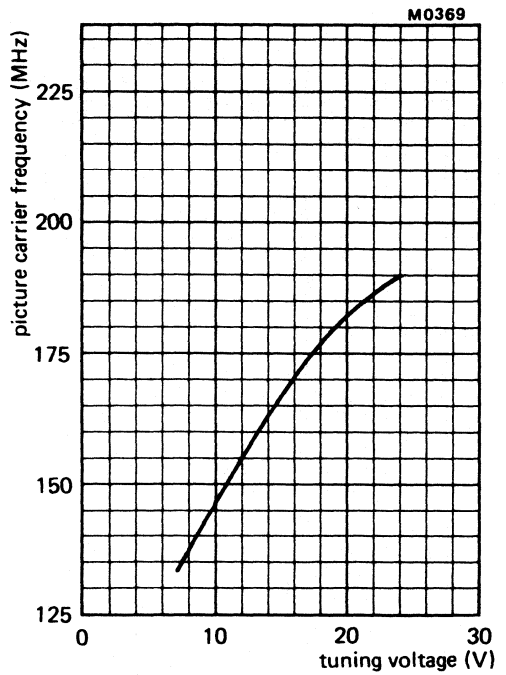

Fig. 8 Typical tuning characteristic, band III.

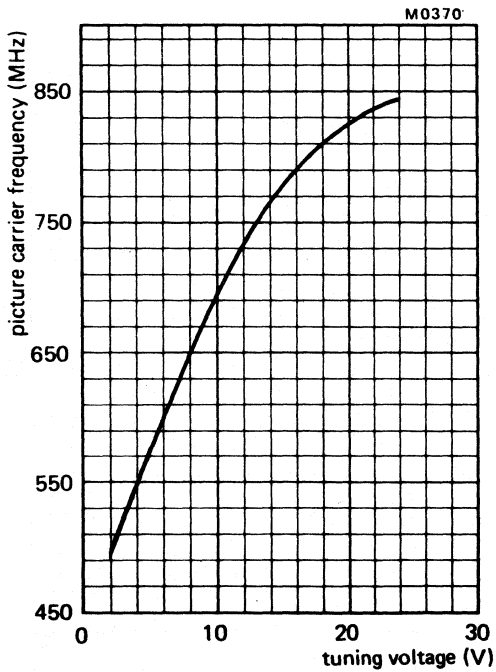

Fig. 9 Typical tuning characteristic, bands IV and V.

Frequencies (continued)Frequency range
band IIIchannel M4 (picture carrier 163,25 MHz)
Margin: min. 2 MHzchannel E12 (picture carrier 224,25 MHz)
Margin: min. 1,8 MHz

bands IV and V

channel E21 (picture carrier 471,25 MHz) to
channel E69 (picture carrier 855,25 MHz)
Margin at the extreme channels: 2 MHz

Intermediate frequencies

picture

32,7 MHz

sound

39,2 MHz

Wanted signal characteristics

Input impedance

75 Ω V.S.W.R. and reflection coefficient
(values between picture and sound carrier,
as well as values at picture carrier)

at nominal gain

during gain control

v.s.w.r.

bands I and III

max. 4

max. 4

bands IV and V

max. 5

max. 6

reflection coefficient

bands I and III

max. 63%

max. 63%

bands IV and V

max. 56%

max. 56%

R.F. curves, bandwidth

band I

typ. 16 MHz

band III

typ. 16 MHz

bands IV and V

typ. 30 MHz

R.F. curves, tilt

on any channel the amplitude difference between
the top of the r.f. resonant curve and the picture
frequency, the sound frequency, or any frequency
between them will not exceed:

nominal gain

in the first 20 dB
of the a.g.c. range

band I

3 dB

4 dB

band III

3 dB

4,5 dB

bands IV and V

3 dB

4 dB

A.G.C. range

bands I and III

min. 40 dB

bands IV and V

min. 30 dB

Wanted signal characteristics (continued)

Power gain (see also measuring method for power gain Figs 11 and 12)

bands I and III	min. 22 dB
bands IV and V	min. 19 dB

Maximum gain difference

between any two v.h.f. channels	typ. 4 dB
between any two u.h.f. channels	typ. 6 dB

Noise figure

bands I and III	max. 7,5 dB
band I	typ. 6 dB
band III	typ. 5 dB
bands IV and V	max. 10 dB
channel E21	typ. 5,5 dB
channel E40	typ. 6,5 dB
channel E69	typ. 7,5 dB

Unwanted signal characteristics

Image rejection (measured at picture carrier frequency)

band I	min. 60 dB
band III	min. 40 dB
bands IV and V	min. 40 dB

I.F. rejection (measured at picture carrier frequency)

band I	
channel A	min. 12 dB
channel B	min. 20 dB
channel C	min. 30 dB
band III	min. 60 dB
bands IV and V	min. 60 dB

Cross modulation

Input signal producing 1% cross modulation, i.e. 1% of the modulation depth of the interfering signal is transferred to the wanted signal.

In channel cross modulation (wanted signal: picture carrier frequency; interfering signal: sound carrier frequency)

band I	
at nominal gain (wanted input level 60 dB (μ V))	typ. 67 dB (μ V) into 75 Ω
at 20 dB gain reduction	typ. 85 dB (μ V) into 75 Ω
band III	
at nominal gain	typ. 70 dB (μ V) into 75 Ω
at 20 dB gain reduction	typ. 90 dB (μ V) into 75 Ω
bands IV and V	
at nominal gain	typ. 70 dB (μ V) into 75 Ω
at 20 dB gain reduction	typ. 90 dB (μ V) into 75 Ω

In band cross modulation (wanted signal: picture carrier of channel N; interfering signal: picture carrier of channel $N \pm 3$ for bands I, III, IV and V).

band III

at nominal gain (wanted input level 60 dB (μ V))

typ. 95 dB (μ V) into 75 Ω

bands IV and V

at nominal gain

typ. 85 dB (μ V) into 75 Ω

Oscillator characteristics

Shift of oscillator frequency at a change of the supply voltage 5%

bands I and III

max. 200 kHz

bands IV and V

max. 1000 kHz

channel 21

typ. 600 kHz

channel 40

typ. 100 kHz

channel 69

typ. 200 kHz

Drift of oscillator frequency at a change of the ambient temperature from +25 to +40 $^{\circ}$ C (measured after 3 cycles from +25 to +55 $^{\circ}$ C)

bands I and III

max. 350 kHz

bands IV and V

max. 600 kHz

I.F. circuit characteristics

Minimum tuning range of i.f. output coil

32 to 40 MHz

Miscellaneous

Oscillator voltage at the aerial terminal

Fundamental and harmonic frequencies up to 1000 MHz

bands I and III

max. 50 dB (μ V) into 75 Ω

bands IV and V

max. 66 dB (μ V) into 75 Ω

ADDITIONAL INFORMATION

I.F. injection

Terminal 4 (supply voltage u.h.f.) can be used as i.f. injection point, provided the u.h.f. supply voltage is applied to terminal 4 via a resistor of $56\ \Omega$ (see Fig. 10). The u.h.f. band should be switched on; a tuning voltage of $-12\ \text{V}$ is applied to terminal 7.

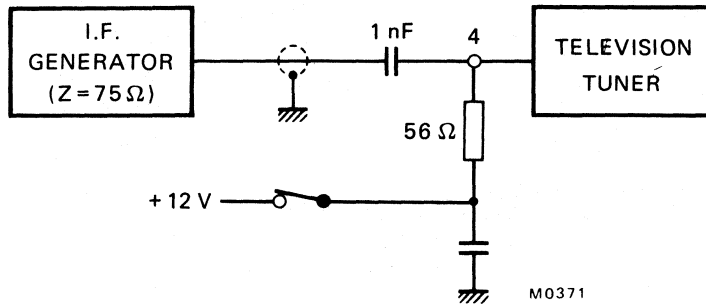

Fig. 10.

Connection of the i.f. amplifier

No special precautions are required to load and to match the i.f. output of the tuner.

Measuring method of power gain

The i.f. output of the tuner should be terminated with the circuit given in Fig. 11.

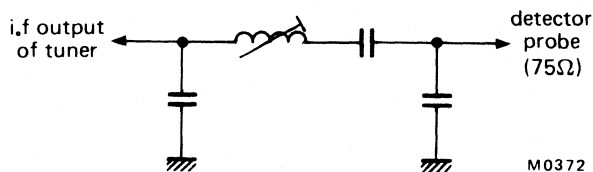

Fig. 11.

This circuit roughly matches the i.f. output impedance to $75\ \Omega$ at the resonant frequency of the i.f. output circuit (Fig. 12).

Because the input and output impedances of the tuner are now $75\ \Omega$, the power gain can be measured in the conventional manner by inserting tuner and the circuit between a $75\ \Omega$ source and a $75\ \Omega$ detector.

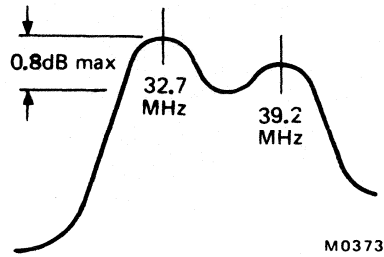

Fig. 12.

Alignment of the i.f. output coil

The i.f. output coil should be adjusted with a brass tool with a blade as shown in Fig. 13. A suitable tool is available under catalogue number 7122 005 47680.

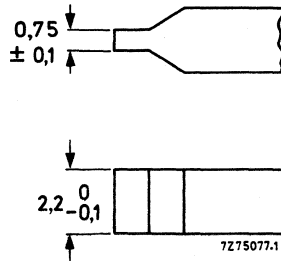

Fig. 13.

V.H.F. TELEVISION TUNER

QUICK REFERENCE DATA

Systems	C.C.I.R. systems M and N (R.T.M.A.)
Channels	
low v.h.f.	A2 to A6
high v.h.f.	A7 to A13
Intermediate frequencies	
picture	45,75 MHz
sound	41,25 MHz

APPLICATION

This tuner is designed to cover the v.h.f. channels of C.C.I.R. systems M and N (R.T.M.A.).

It can be provided with a frequency divider, which makes this tuner suitable for digital tuning systems based on frequency synthesis.

DESCRIPTION

This v.h.f. tuner has electronic tuning and band switching, covering the low v.h.f. band channels A2 to A6 (frequency range 54 to 88 MHz) and the high v.h.f. band channels A7 to A13 (frequency range 174 to 216 MHz).

Mechanically, the tuner is built on a low-loss printed-wiring board, carrying all components, in a metal housing made of a rectangular frame and front and rear cover (see Fig. 2a). All connections (supply voltage, a.g.c. voltage, tuning voltage, band switching, i.f. output) are made via terminals on the underside, except the coaxial aerial connection of 75Ω which is on one of the frame sides. The mounting method is shown in Fig. 3.

Electrically the v.h.f. aerial signal is fed via low pass, high pass, i.f. and f.m. suppression filters to a switchable single tuned input circuit for low and high v.h.f. operation, which is capacitively coupled to the gate 1 of a MOS-FET tetrode (with internal gate protection against surge). The drain load of the MOS-FET tetrode is formed by a double tuned, switchable bandpass filter, transferring the r.f. signal to the emitter of the mixer transistor. The oscillator signal is also fed to the emitter of the mixer transistor.

The collector circuit of the mixer transistor is a single tuned i.f. resonant circuit, where the i.f. signal is coupled out at the low impedance side.

A test point (terminal 4) is provided for i.f. injection to adjust the i.f. output circuit of the tuner together with the i.f. amplifier of a television receiver. An additional test point, which is accessible through a hole in the top of the frame, is connected with the collector of the v.h.f. mixer transistor.

The single tuned input, the r.f. bandpass filter and oscillator circuits are tuned by 4 varicap diodes, band switching is achieved by switching diodes.

The tuner is gain controlled via gate 2 of the input MOS-FET tetrode.

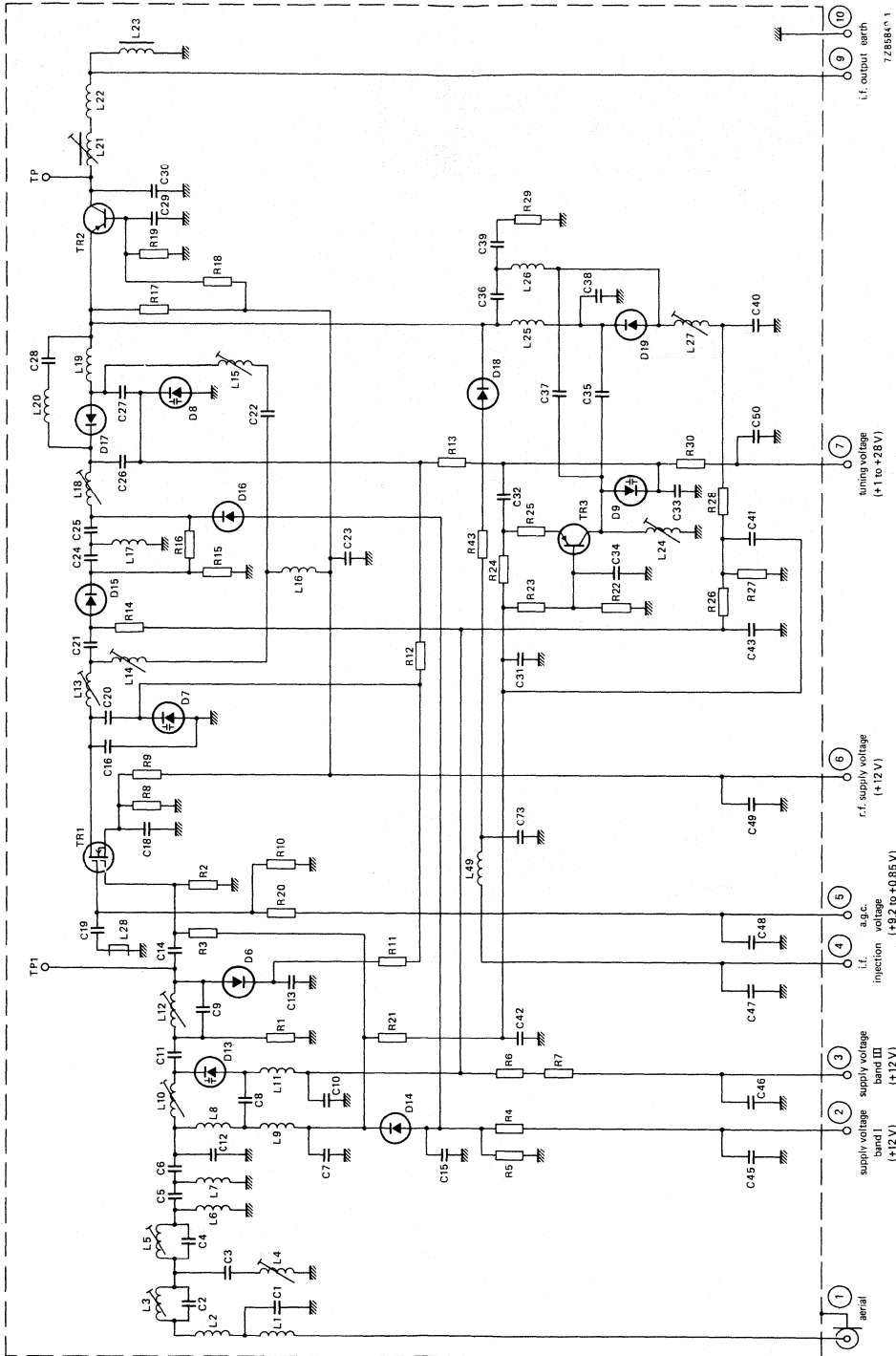
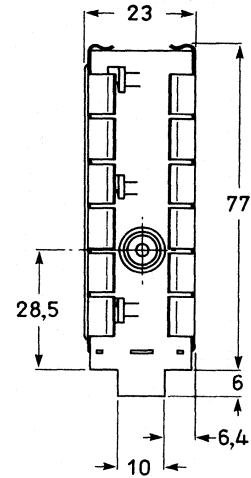
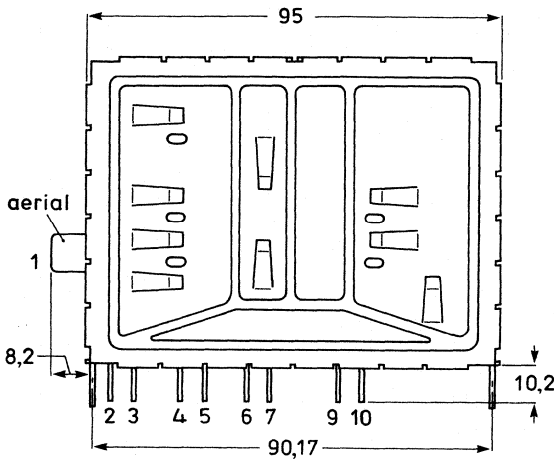
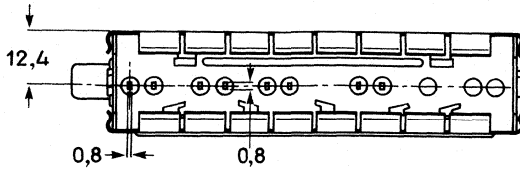

Fig. 1.

MECHANICAL DATA

Dimensions in mm



7285848

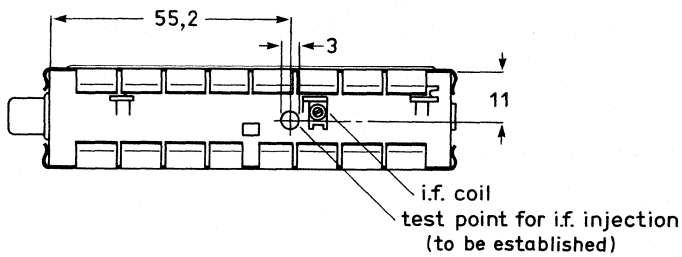

Fig. 2a.

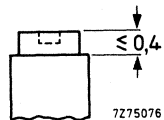

Fig. 2b I.F. output coil.
Torque for alignment: 2 to 15 mNm
Press-through force: ≥ 10 N

Terminal

- 1 = aerial
- 2 = supply voltage, v.h.f. I, +12 V
- 3 = supply voltage, v.h.f. III, +12 V
- 4 = i.f. injection
- 5 = a.g.c. voltage, +9,2 to +0,85 V
- 6 = supply voltage, +12 V
- 7 = tuning voltage, +1 to +28 V
- 9 = i.f. output
- 10 = earth

Mass approx. 125 g.

Mounting

The tuner may be mounted by soldering it on to a printed-wiring board, using the piercing diagram shown in Fig. 3. (The tuner may also be mounted by means of a bracket. Information will be supplied upon request.)

It is recommended that the tuner be installed in the cool part of the receiver cabinet and not exposed to the vibrations of the loudspeaker. There are no restrictions on orientation.

The solderability of the terminals and mounting tabs is according to IEC 68-2, test Ta (230 ± 10 °C, $2 \pm 0,5$ s). The resistance to soldering heat is according to IEC 68-2, test Tb (260 ± 5 °C, 10 ± 1 s).

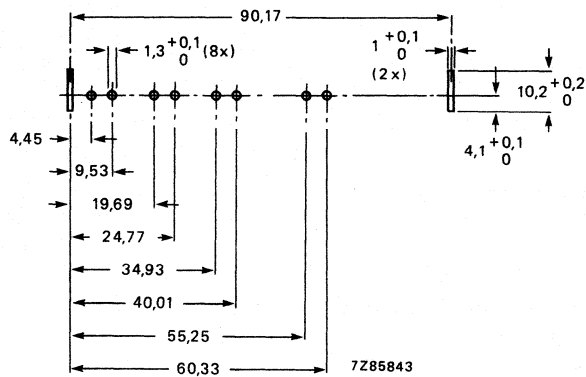

Fig. 3 Piercing diagram viewed from solder side of board. Unless otherwise stated the tolerance is $\pm 0,05$ mm.

Marking

The tuner is provided with a label showing the following data:

- type number V431
- catalogue number 3112 218 51830
- code for factory of origin
- change code
- code for year and week of production

ELECTRICAL DATA

Unless otherwise specified all electrical values apply at an ambient temperature of 25 ± 5 °C, a relative humidity of $60 \pm 15\%$, a supply voltage of $12 \pm 0,3$ V and an a.g.c. voltage of $9,2 \pm 0,2$ V.

General**Semiconductors**

r.f. amplifier	BF982
mixer	BF324
oscillator	BF926
tuning diodes	4 x BB809
switching diodes	4 x BA482/483/484
d.c. blocking diodes	3 x BAW62

Ambient temperature range

operating	0 to +60 °C
storage	-25 to +70 °C

Relative humidity

max. 95%

Voltage and currents**Supply voltage**+12 V \pm 10%***Current drawn from +12 V supply**

low v.h.f.	max. 52 mA; typ. 39 mA
high v.h.f.	max. 52 mA; typ. 39 mA

Bandswitching

For operation in both bands the supply voltage is permanently connected to terminal 6. Additionally the supply voltage is connected to:

- terminal 2 for operation in the low v.h.f. band,
- terminal 3 for operation in the high v.h.f. band,
- terminal 4 for i.f. injection

A.G.C. voltage

voltage range	+9,2 to +0,85 V
voltage at nominal gain	+9 \pm 0,5 V
voltage at 40 dB gain reduction	
low v.h.f.	typ. 3,2 V
high v.h.f.	typ. 1,5 V

Note: A.G.C. voltages between 0 and +10,5 V may be applied without risk of damage.

A.G.C. current

max. 0,1 mA

Slope of a.g.c. characteristic,

at the end of the specified a.g.c. range	typ. 25 dB/V
--	--------------

* A tolerance of -15% on the supply voltage is admissible, if a deterioration of gain, noise figure, oscillator shift and oscillator drift is acceptable.

Tuning voltage range (Figs 4 and 5) +1 to +28 V

Current drawn from 28 V tuning voltage supply

at $T_{amb} = 25\text{ }^{\circ}\text{C}$ and R.H. = 60%

max. 0,3 μA

at $T_{amb} = 25\text{ }^{\circ}\text{C}$ and R.H. = 95%

max. 1 μA

at $T_{amb} = 55\text{ }^{\circ}\text{C}$ and R.H. = 60%

max. 1 μA

Note: The source impedance of the tuning voltage offered to terminal 7 must be maximum 47 k Ω .

Slope of tuning characteristic

low v.h.f. channel A2

3 MHz/V

channel A6

2 MHz/V

high v.h.f. channel A7

6 MHz/V

channel A13

4 MHz/V

} typical values

Frequencies

Frequency ranges

low v.h.f.

channel A2 (picture carrier 55,25 MHz) to
channel A6 picture carrier 83,25 MHz).*

Margin at the extreme channels: min. 1,5 MHz.

high v.h.f.

channel A7 (picture carrier 175,25 MHz) to
channel A13 (picture carrier 211,25 MHz).

Margin at the extreme channels min. 2 MHz.

Intermediate frequencies

picture

45,75 MHz

sound

41,25 MHz

The oscillator frequency is higher than the
aerial signal frequency.

Wanted signal characteristics

Input impedance

75 Ω

V.S.W.R. and reflection coefficient
(values between picture and sound carrier,
as well as values at picture carrier)

v.s.w.r.

all channels except A6

at nominal gain

max. 4

during gain control

max. 5

channel A6

max. 5

max. 5

reflection coefficient

all channels except A6

max. 60%

max. 66%

channel A6

max. 66%

max. 66%

R.F. curves, bandwidth

low v.h.f.

typ. 10 MHz

high v.h.f.

typ. 12 MHz

R.F. curves, tilt	on any channel the amplitude difference between the top of the r.f. resonant curve and the picture frequency, the sound frequency, or any frequency between them will not exceed 3 dB at nominal gain, and 4 dB in the a.g.c. range between nominal gain and 20 dB gain reduction, except for channel A6.
A.G.C. range (Figs 6 and 7)	min. 40 dB
Power gain (see also Measuring method of power gain)	
channel A4	min. 22 dB
channel A7	typ. 26 dB
channel A13	typ. 26 dB
Maximum gain difference between any two v.h.f. channels	typ. 27 dB
Noise figure	
all channels except A6	typ. 4 dB
channel A6	max. 7 dB
channel A4	max. 9 dB
channel A7	typ. 5 dB
channel A13	typ. 5 dB
Overloading:	
Input signal producing 1 dB gain compression at nominal gain	typ. 90 dB (μ V) into 75 Ω
Input signal producing either a detuning of the oscillator of +300 kHz or -1000 kHz or stopping of the oscillations at nominal gain	typ. 100 dB (μ V) into 75 Ω
Unwanted signal characteristics	
Image rejection (measured at picture carrier frequency)	min. 60 dB; typ. 70 dB
I.F. rejection (measured at picture carrier frequency)	
low v.h.f. channel A2	min. 45 dB
low v.h.f. channels A3 to A6	min. 50 dB
high v.h.f.	min. 60 dB

Note: At colour sub-carrier frequency maximum 6 dB less rejection.

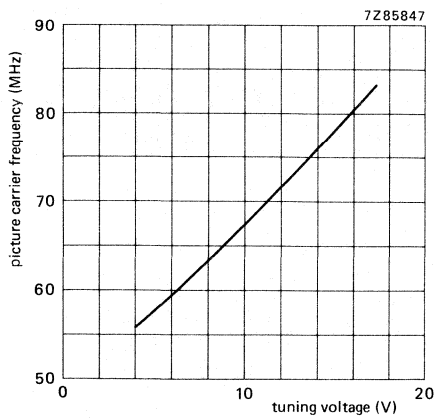

Fig. 4 Typical tuning characteristic, low v.h.f.

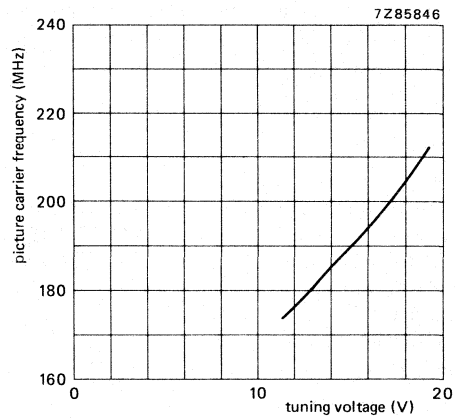

Fig. 5 Typical tuning characteristic, high v.h.f.

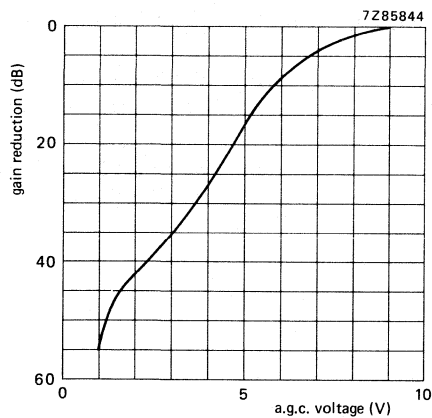

Fig. 6 Typical a.g.c. characteristic, low v.h.f.

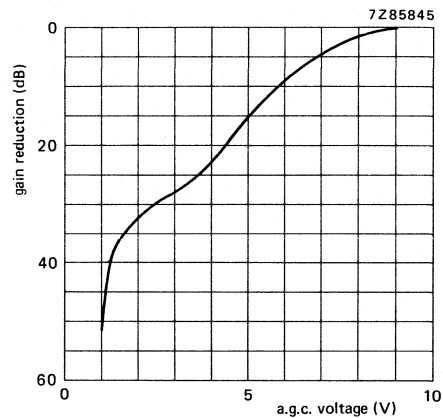

Fig. 7 Typical a.g.c. characteristic, high v.h.f.

F.M. rejection, low v.h.f.

Level of an f.m. signal of 91,5 MHz which produces an i.f. signal (47,75 MHz) 57 dB below the level of the wanted picture carrier

channel A2	typ. 100 dB (μV)
channel A4	typ. 100 dB (μV)
channel A6	typ. 60 dB (μV)

F.M. rejection, high v.h.f.

Level of an f.m. signal between 88 and 105 MHz, which produces an i.f. interfering (45,75 MHz) 57 dB below the level of the wanted picture carrier. Level of input picture carrier is 60 dB μV

channel A8	typ. 95 dB (μV)
channel A11	typ. 92 dB (μV)
channel A13	typ. 95 dB (μV)

Cross modulation:

Input signal producing 1% cross modulation, i.e. 1% of the modulation depth of the interfering signal is transferred to the wanted signal.

In channel cross modulation (wanted signal: picture carrier frequency; interfering signal: sound carrier frequency)

at nominal gain (wanted input level 60 dB (μV))	typ. 76 dB (μV) into 75 Ω
at 40 dB gain reduction (wanted input level 100 dB (μV))	typ. 94 dB (μV) into 75 Ω

In band cross modulation (wanted signal: picture carrier of channel N; interfering signal: picture carrier of channel N \pm 2 for low v.h.f. or channel N \pm 3 for high v.h.f.)

at nominal gain (wanted input level 60 dB (μV))	typ. 88 dB (μV) into 75 Ω
at 40 dB gain reduction (wanted input level 100 dB (μV))	typ. 100 dB (μV) into 75 Ω

Out of band cross modulation at nominal gain

low v.h.f., interfering from high v.h.f.	typ. 100 dB (μV) into 75 Ω
high v.h.f., interfering from low v.h.f.	typ. 90 dB (μV) into 75 Ω

Oscillator characteristics**Pulling:**

Input signal of tuned frequency producing a shift of the oscillator frequency of 10 kHz, at nominal gain

low v.h.f.

typ. 88 dB (μ V) into 75 Ω

high v.h.f.

typ. 86 dB (μ V) into 75 Ω

Shift of oscillator frequency at a change of the supply voltage of 5%

max. 200 kHz

When using supply circuit of Fig. 10 additional shift

max. 150 kHz

Drift of oscillator frequency

during warm-up time (after the tuner has been completely out of operation for 15 min, measured between 5 s and 15 min after switching on)

max. 250 kHz

during warm-up time (after the input stage is in operation for 15 min, measured between 2 s and 15 min after band switching)

max. 250 kHz

at a change of the ambient temperature from +25 to +50 $^{\circ}$ C (measured after 3 cycles from +25 to +55 $^{\circ}$ C)

max. 600 kHz

at a change of humidity from 60 \pm 15% to 93 \pm 2% (measured at $T_{amb} = 25 \pm 5$ $^{\circ}$ C)

low v.h.f.

max. 500 kHz

high v.h.f.

max. 1000 kHz

I.F. circuit characteristics

Bandwidth of i.f. output circuit $5 \pm 0,5$ MHz

Note: I.F. output of the tuner terminated with the circuit shown in Fig. 8; tuning voltage 15 V, high v.h.f. band switched on.

Bandwidth variation of i.f. output circuit as a result of r.f. tuning and band switching (reference: high v.h.f., tuning voltage 15 V; i.f. output circuit adjusted to 43,5 MHz)

max. 650 kHz

Note: I.F. output of the tuner terminated with a modified circuit of Fig. 8, i.e. a 100 pF capacitor is connected in parallel with the i.f. output of the tuner.

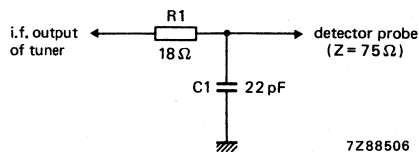

Fig. 8.

Detuning of the i.f. output circuit as a result of r.f. tuning and band switching (reference: high v.h.f. tuning voltage 15 V; i.f. output circuit adjusted to 43,5 MHz)

max. 300 kHz

Note: I.F. output of the tuner terminated with a modified circuit of Fig. 8, i.e. a 100 pF capacitor is connected in parallel with the i.f. output of the tuner.

Minimum tuning range of i.f. output coil

41 to 47 MHz

Note: I.F. output of the tuner terminated with the circuit shown in Fig. 8. The tuner is supplied with the i.f. output circuit adjusted to $43,5 \pm 1$ MHz.

Attenuation between i.f. injection point and i.f. output of the tuner

typ. 16 dB

Miscellaneous

Radio interference:

Oscillator radiation and oscillator voltage at the aerial terminal

Within the limits of C.I.S.P.R. 13 (1975)

Microphonics

There will be no microphonics, provided the tuner is installed in a professional manner.

Surge protection:

Protection against voltages

max. 5 kV

Note: 10 discharges of a 470 pF capacitor into the aerial terminal.

Protection against flashes

max. 30 kV, 400 mWs

Note: A flashover circuit producing flashes with frequencies of 1 to 20 Hz for 30 s is connected to the aerial terminal.

ADDITIONAL INFORMATION

I.F. injection

Terminal 4 can be used as i.f. injection point. The i.f. generator is connected according to Fig. 9. High v.h.f. should be switched on; tuning voltage should be 15 V.

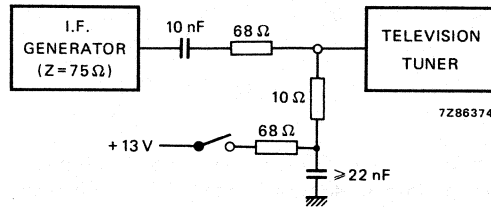

Fig. 9.

Connection of the i.f. amplifier

- By means of a print track as short as possible.
- By means of a shielded track, e.g. a coaxial cable.

Connection of supply voltages

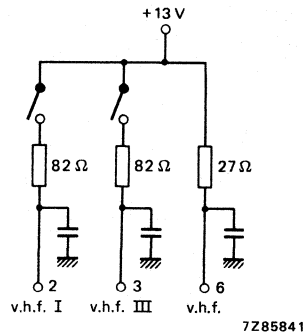

Fig. 10.

Measuring method of power gain

The i.f. output of the tuner should be terminated with the RC-circuit given in Fig. 8.

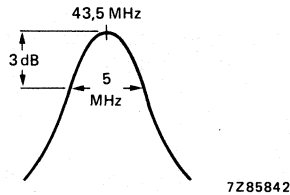

Fig. 11.

The RC-circuit roughly matches the i.f. output impedance to 75Ω at the resonant frequency of the i.f. output circuit which should be tuned to 43,5 MHz; the bandwidth is approx. 5 MHz (Fig. 11).

Because the input and output impedances of the tuner are now 75Ω , the power gain can be measured in the conventional manner by inserting tuner and RC-circuit between a 75Ω source and a 75Ω detector.

Alignment of the i.f. output coil

The i.f. output coil should be adjusted with a brass tool with a blade as shown in Fig. 12. A suitable tool is available under catalogue number 7122 005 47680.

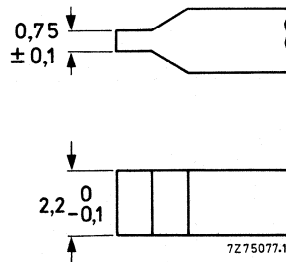

Fig. 12.

TESTS AND REQUIREMENTS

IEC 68-2	test	procedure	requirements
Ab	cold	-25 °C, 96 h	Checked within 10 min after all tests mentioned: no catastrophic failures (in operation of 1 or more channels).
Bb	dry heat	+70 °C, 96 h	
Db	damp heat, cyclic	+25 to +40 °C R.H. 90 to 100% 21 cycles of 24 h	
Ca	damp heat, steady state	-40 °C, R.H. 93% 21 days	After 1 h reconditioning under normal conditions: change of osc. freq. band I ≤ 1,5 MHz band III ≤ 2 MHz change of power gain ≤ 2 dB change of tilt r.f. curve ≤ 2 dB change of tuning current ≤ 0,5 μA
Na	rapid change of temperature	3h -25 °C/3h +70 °C 5 cycles	
Fc	vibration	10-55-10 Hz, amplitude 0,35 mm 3 directions, 30 min per direction	
Eb	bump	1000 bumps, acceleration 25 g, in 6 directions	
Ea	shock	half sine pulse 11 ms, acceleration 50 g in 6 directions 3 times per direction	

COAXIAL AERIAL INPUT ASSEMBLIES

COAXIAL AERIAL INPUT ASSEMBLY

QUICK REFERENCE DATA

Frequency range	40 to 890 MHz
Impedance	75 Ω asymmetrical

APPLICATION

This coaxial aerial input assembly has been developed for application in TV sets without mains separation and provided with a television tuner of the UV400 family. Thanks to the use of safety capacitors in the assembly, the chassis of the TV set is separated from the aerial input. The input connector of the assembly meets the demands of IEC 169.2 and DIN 45325 (diameter 9,5 mm).

The coaxial aerial input assembly complies with the requirements of immunity from radiated interference of Amtsblatt DBP69/1981. It meets the safety requirements of IEC 65; approbation approval has been sought from VDE.

DESCRIPTION

The assembly is provided with safety capacitors, which are moulded in thermo-setting insulation material, thus forming capacitor blocks. These capacitor blocks are built in a metal housing with cover, and are connected to the housing, coaxial cable and the output plug (see Fig. 1). The coaxial cable is a double insulated, screened 75 Ω cable, which leads to the female input connector on a plastic plate. The output connector (phono) is mounted on the housing and fits the aerial input of the tuner (see Fig. 2).

The assembly can be supplied with three cable lengths:

free cable length	catalogue number
90 mm	3122 127 01240
145 mm	3122 127 03500
250 mm	3122 127 05900

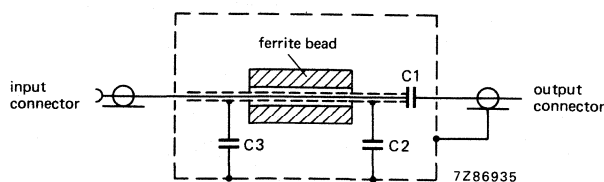

Fig. 1 Ferrite bead = $\phi 8 \times \phi 3 \times 10$ mm.

$C_1 = 390$ pF
 $C_2 = 1000$ pF
 $C_3 = 1000$ pF

ELECTRICAL DATA

The electrical values are measured at an ambient temperature of $25 \pm 5 \text{ }^\circ\text{C}$ and a relative humidity of $60 \pm 15\%$.

Impedance of input connector	75 Ω , asymmetric
Impedance of output plug	75 Ω , asymmetric
Frequency range	40 to 890 MHz
Reflection at the input connector, output plug matched with phono connector 3122 128 74660 and 75 Ω	
40 to 470 MHz	$\leq 25\%$
470 to 700 MHz	$\leq 35\%$
700 to 890 MHz	$\leq 45\%$
Reflection at the output plug, input connector matched with IEC plug and 75 Ω	
40 to 470 MHz	$\leq 25\%$
470 to 700 MHz	$\leq 35\%$
700 to 890 MHz	$\leq 45\%$
Insertion loss	
40 to 700 MHz	max. 1,5 dB, typ. 0,6 dB
700 to 890 MHz	max. 2,0 dB, typ. 1,4 dB
Contact resistance of input connector	
inner conductor	$\leq 10 \text{ m}\Omega$
outer conductor	$\leq 5 \text{ m}\Omega$
Contact resistance of output plug	
inner conductor	$\leq 10 \text{ m}\Omega$
outer conductor	$\leq 10 \text{ m}\Omega$
Insulation resistance	$\leq 500 \text{ M}\Omega$
Immunity from radiated interference	in conformity with requirements of Amtsblatt DBP69/1981 provided the unit is connected to a television tuner of the UV400 family in the right way.
Safety	the unit meets the requirements of IEC 65, 4th edition, clause 14.2. Approbation approval has been sought from VDE. Quality assessment in production centres is according to the rules of VDE.

ENVIRONMENTAL CONDITIONS

Operating temperature range	0 to + 55 $^\circ\text{C}$
Storage temperature range	-40 to + 70 $^\circ\text{C}$
Relative humidity	$\leq 95\%$
Maximum bump acceleration	245 m/s^2 (25g)
Maximum shock acceleration	490 m/s^2 (50g)
Maximum vibration amplitude	0,35 mm

MECHANICAL DATA

Dimensions in mm

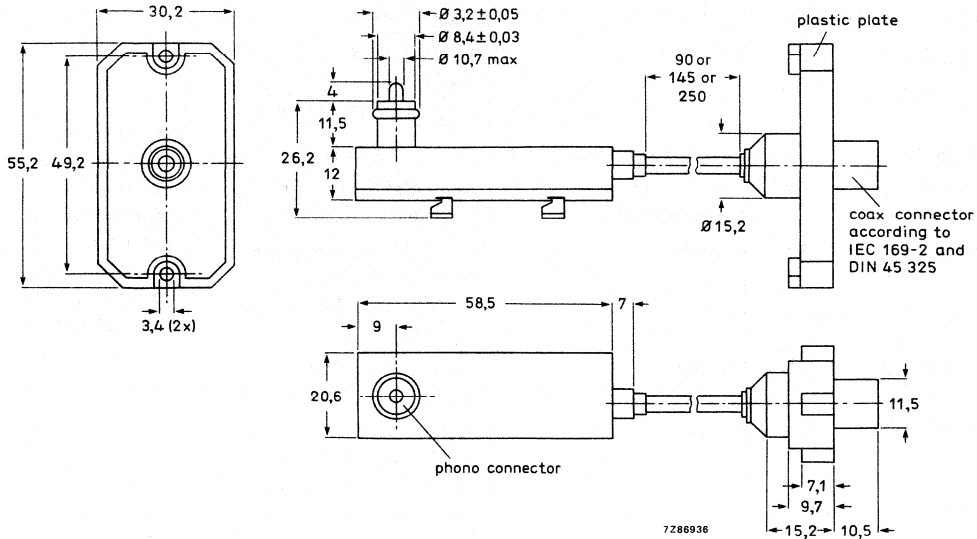

Fig. 2.

Mass 50 g approximately

MOUNTING

The metal housing is connected to the television tuner of the UV400 family by inserting the phono plug into the aerial input plug of the tuner. The plastic plate with input connector can be fixed by means of two M3 screws (13 mm) or by using a snap-in holder.

It is advised not to use aluminium plugs.

Insertion force

input connector	max. 50 N
inner conductor of output plug	max. 30 N

Pull-out force

input connector	10 to 50 N
inner conductor of output plug	min. 3 N

Tensile strength to cable connections at both sides

max. 100 N

TESTS AND REQUIREMENTS

IEC publication		name of test	procedure	requirements
IEC 68-2-1	Ab	cold	-40 °C, 96 h	all requirements mentioned under electrical and mechanical data must be met, except the insulation resistance which must be min. 300 MΩ
IEC 68-2-2	Bb	dry heat	+ 70 °C, 96 h	
IEC 68-2-30	Db	damp heat, cyclic	+ 25/+ 40 °C, 90/100% R.H., 21 cycles of 24 h	
IEC 68-2-3	Ca	damp heat, steady state	+ 40 °C, 93% R.H.; 21 days	
IEC 68-2-14	Na	rapid change of temperature	3 h -40 °C/3 h + 70 °C, 5 cycles	
IEC 68-2-6	Fc	vibration	10-55-10 Hz, sinusoidal, amplitude 0,35 mm, 3 directions, 30 min per direction	
IEC 68-2-29	Eb	bump	1000 bumps, 25g, 6 directions	
IEC 68-2-27	Ea	shock	half sinewaves of 11 ms, accel. 50g, 6 directions, 3 shocks per direction	

MARKING

Moulded in the front side of the plastic plate (see Fig. 2):

- PHILIPS
- 7106 (safety code)
- 250 V; 390 pF 1x, 1000 pF 2x

PACKING

The assemblies are supplied in cardboard boxes of 490 x 295 x 153 mm, 64 pieces per box.

COAXIAL AERIAL INPUT ASSEMBLY

APPLICATION

These coaxial aerial input assemblies have been developed for application in television sets with 75 ohm input impedance, for use in v.h.f. as well as in u.h.f. (40-890 MHz). The connectors meet the demands of both the IEC standards (diameter 9,5 mm) and the French standards (diameter 9,0 mm). They have to be used with plugs complying with the properties mentioned in DIN 45325, IEC 169-2 (diameter 9,5 mm) and SNIR (diameter 9,0 mm). The units meet the safety requirements of IEC 65.

AVAILABLE TYPES

Coaxial aerial input assembly 75 Ω

Attenuation	: ≤ 1 dB
Reflection, v.h.f.	: $\leq 15\%$
u.h.f.	: $\leq 25\%$
Catalogue number	: 3122 127 10260

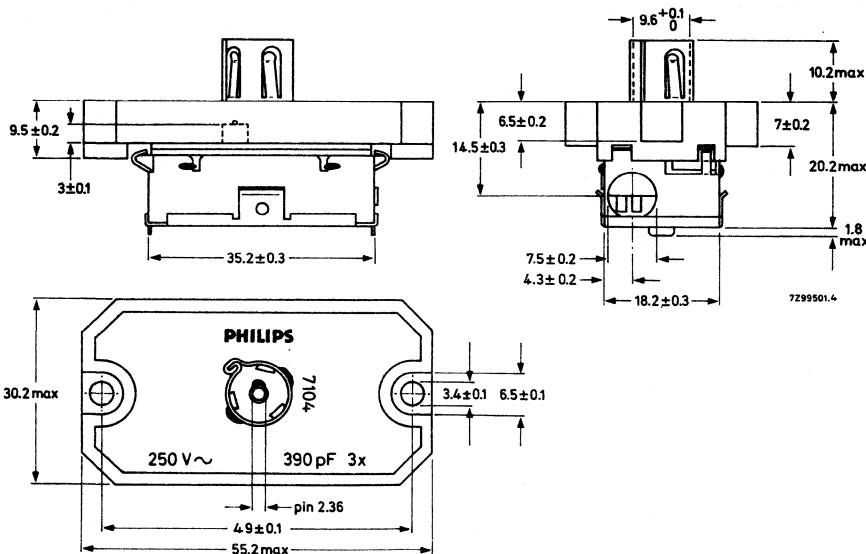
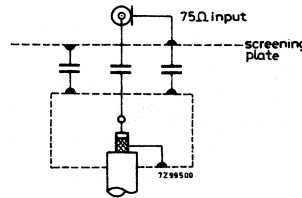

Dimensions in mm

3122 127 10260
 3122 127 10450
 3122 127 14730

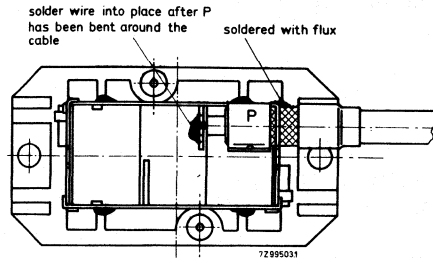

Recommended fixing of the aerial cable
 Soldering conditions: 370 ± 5 °C; $3,5 \pm 0,5$ s

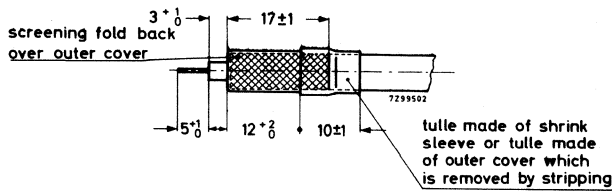

Cable diameter ≥ 5 mm

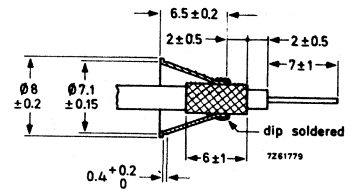

Cable diameter < 5 mm

Coaxial aerial input assembly 75 Ω, with filter

Reflection, v. h. f. $\leq 25\%$
 u. h. f. $\leq 30\%$

Frequency characteristic
 v. h. f. , 50 to 230 MHz ≤ 1 dB
 470 MHz ≥ 13 dB
 700 MHz 23 dB (typical value)
 u. h. f. , 470 to 850 MHz ≤ 1 dB
 230 MHz ≥ 15 dB
 100 MHz 40 dB (typical value)

Catalogue number 3122 127 10450

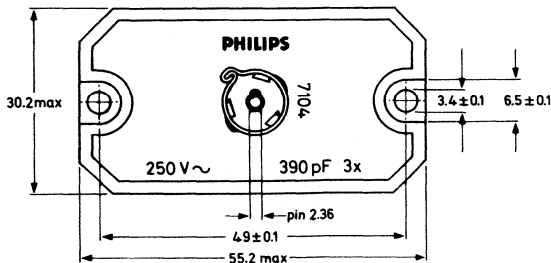
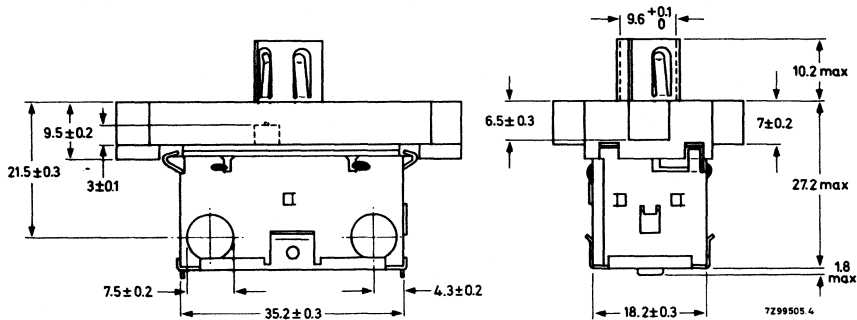
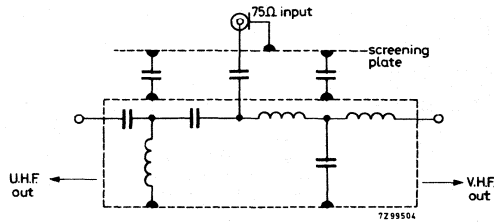

Dimensions in mm

3122 127 10260
 3122 127 10450
 3122 127 14730

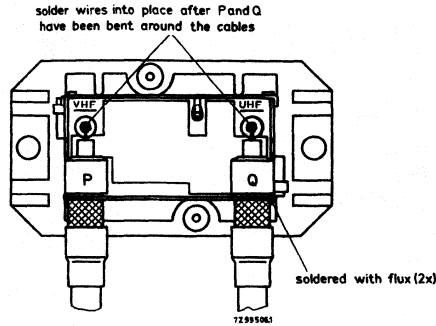

Recommended fixing of the aerial cable
 Soldering conditions: $370 \pm 5 \text{ }^\circ\text{C}$; $3, 5 \pm 0, 5 \text{ s}$

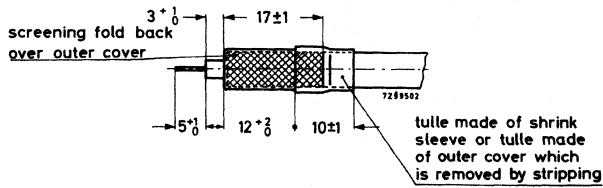

Cable diameter $\geq 5 \text{ mm}$

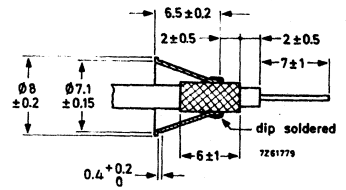

Cable diameter $< 5 \text{ mm}$

Coaxial aerial input assembly 75 Ω, with high-pass filter

Attenuation at 1 MHz : 60 dB (typical value)
 5 MHz : 40 dB (typical value)
 10 MHz : ≥ 25 dB
 50 MHz : ≤ 1 dB
 230 MHz : ≤ 1 dB
 470 MHz : ≤ 1 dB
 850 MHz : ≤ 1,5 dB

Reflection, v. h. f. I : ≤ 35%
 v. h. f. III : ≤ 15%
 u. h. f. : ≤ 35%

Catalogue number : 3122 127 14730

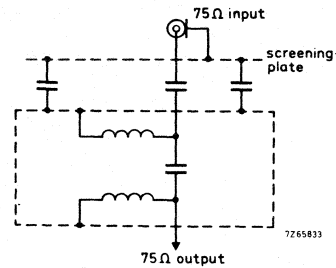

Dimensions in mm

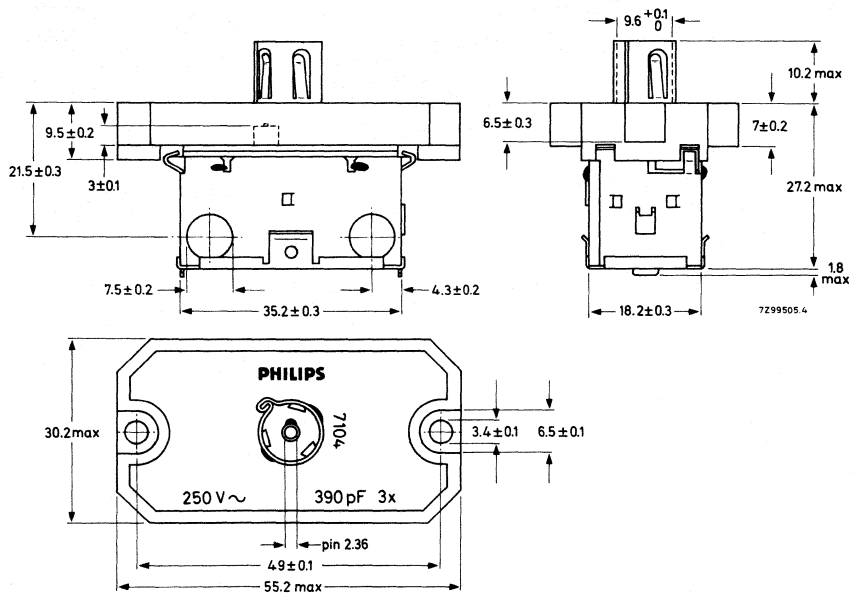

3122 127 10260
 3122 127 10450
 3122 127 14730

solder wires into place after P has
 been bent around the cable

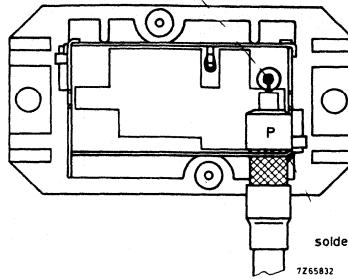

soldered with flux (2x)

Recommended fixing of the aerial cable
 Soldering conditions: 370 ± 5 °C; $3,5 \pm 0,5$ s

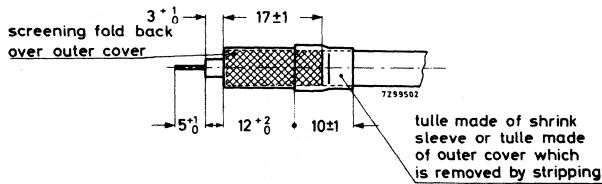

Cable diameter ≥ 5 mm

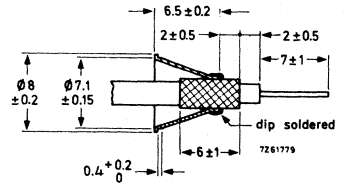

Cable diameter < 5 mm

COAXIAL AERIAL INPUT ASSEMBLY

APPLICATION

This coaxial aerial input assembly has been developed for application in TV sets with 75Ω input impedance, for use in v.h.f. as well as in u.h.f. bands. Thanks to the use of safety capacitors in the assembly, the chassis of the TV set is separated from the aerial input. The connector for the aerial input meets the demands of the IEC standards (diameter 9,5 mm) and the French standards (diameter 9,0 mm).

The coaxial aerial input assembly complies with the requirements of immunity from radiated interference of BS 905. It meets the safety requirements of IEC 65; approbation approvals have been sought from KEMA, VDE, SEV, BSI, DEMKO, NEMKO, SEMKO, EI and LCEE.

DESCRIPTION

The assembly is provided with safety capacitors, which are moulded in thermo-setting insulation material, thus forming a capacitor block. This capacitor block is built in a metal housing, with lid, which is carried by a plastic fixing plate. All points to the safety capacitors are press contacts, achieved by the metal housing. The housing has an outlet for the coaxial cable to the television tuner.

ELECTRICAL DATA

The electrical values are measured at an ambient temperature of 25 ± 5 °C and a relative humidity of $60 \pm 15\%$.

Input impedance of connector	75 Ω , asymmetrical
Frequency ranges	
v.h.f.	40 to 300 MHz
u.h.f.	470 to 890 MHz
Reflection	
v.h.f.	$\leq 15\%$
u.h.f.	$\leq 25\%$
Insertion loss	
v.h.f.	≤ 1 dB; typ. 0,2 dB
u.h.f.	≤ 1 dB; typ. 0,4 dB
Contact resistance of connector after 1 plug insertion	
inner bush	≤ 10 m Ω
outer bush	≤ 5 m Ω
Insulation resistance	> 500 M Ω
Immunity from radiated interference	in conformity with requirements of BS 905, provided the assembly is installed in a professional manner, and a proper coaxial cable is used.

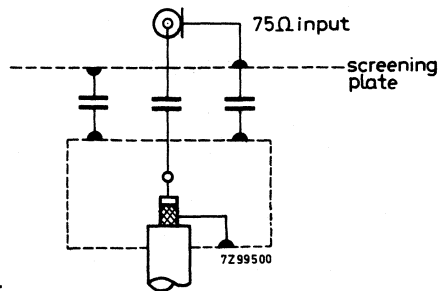

Fig. 1.

ENVIRONMENTAL DATA

Operating temperature range	0 to +55 °C
Storage temperature range	-40 to +85 °C
Relative humidity	$\leq 95\%$

MECHANICAL DATA

Dimensions in mm

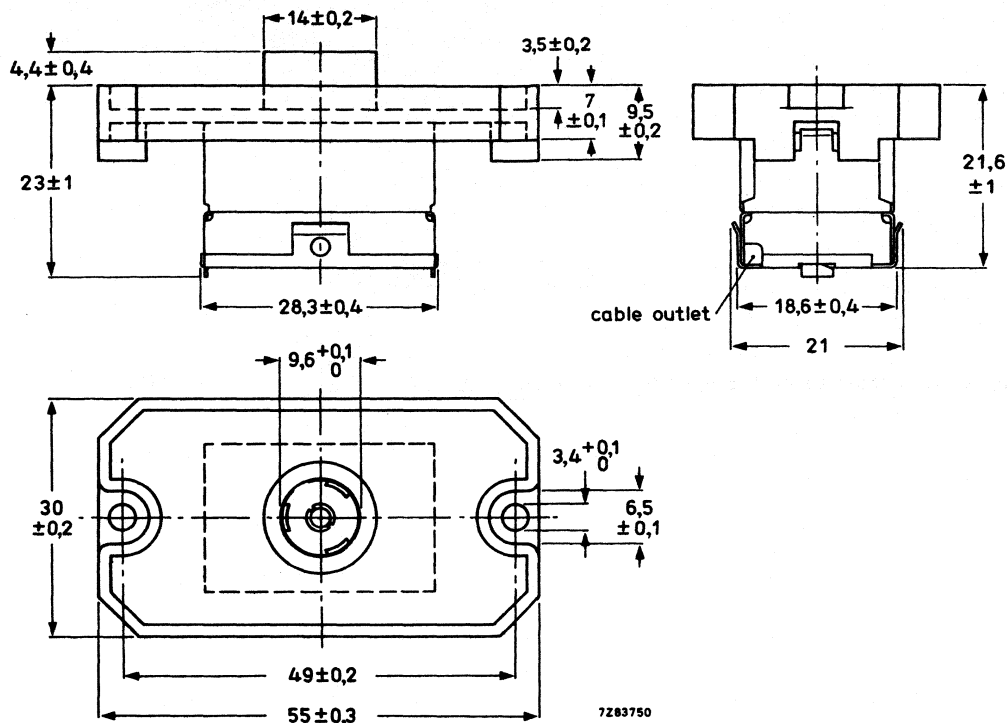

Fig. 2.

MOUNTING

The assembly can be mounted to the chassis of the TV set with two self-tapping screws, 4N x 9,5.

It must be connected to the tuner via a coaxial cable with a diameter of 3 mm. The inner cable conductor should be soldered to the metal plating of the capacitor block, and the cable earth sheath to the metal housing, see Fig. 3.

The soldering conditions are: 340 °C, 2 s.

Plugs to be used with the assembly have to comply with the properties mentioned in DIN 45325, IEC 69-2 (9,5 mm diameter) and SNIR (9 mm diameter).

It is advised not to use aluminium plugs.

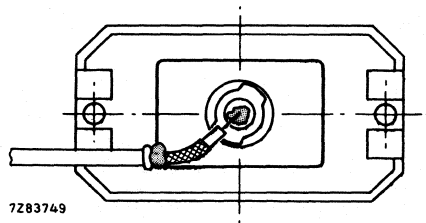

Fig. 3 Recommended fixing of the aerial cable.

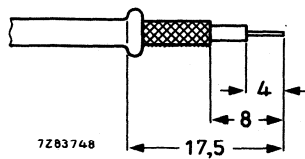

Fig. 4 Recommended cable stripping.

COAXIAL AERIAL INPUT ASSEMBLY

APPLICATION

This coaxial aerial input assembly has been developed for application in TV sets with $75\ \Omega$ input impedance, for use in v.h.f. as well as in u.h.f. bands. Thanks to the use of safety capacitors in the assembly, the chassis of the TV set is separated from the aerial input. The connector for the aerial input meets the demands of the IEC standards (diameter 9,5 mm) and the French standards (diameter 9,0 mm).

The coaxial aerial input assembly complies with the requirements of immunity from radiated interference of BS 905. It meets the safety requirements of IEC 65; approbation approvals have been sought from KEMA, VDE, SEV, BSI, DEMKO, NEMKO, SEMKO, EI and LCEE.

DESCRIPTION

The assembly is provided with safety capacitors, which are moulded in thermo-setting insulation material, thus forming a capacitor block. This capacitor block is built in a metal housing with lid, which is carried by a plastic fixing plate. All points to the safety capacitors are press contacts, achieved by the metal housing. A printed circuit board containing a splitter for v.h.f. and u.h.f. signals is built in the housing. The housing has two outlets for coaxial cables to the television tuner.

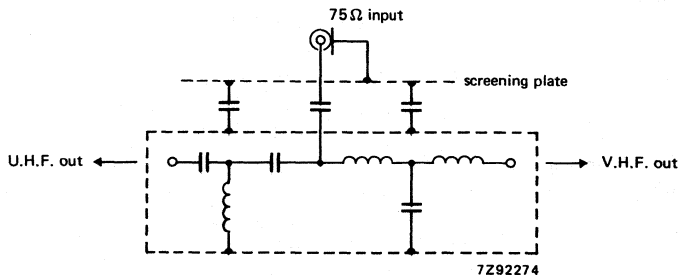

Fig. 1 Electrical diagram.

ELECTRICAL DATA

The electrical values are measured at an ambient temperature of 25 ± 5 °C and a relative humidity of $60 \pm 15\%$.

Input impedance of connector	75 Ω , asymmetrical
Frequency ranges	
v.h.f.	40 to 300 MHz
u.h.f.	470 to 890 MHz
Reflection	
v.h.f.; u.h.f. output terminated with 75 Ω	$\leq 30\%$
u.h.f.; v.h.f. output terminated with 75 Ω	$\leq 30\%$
Insertion loss	
v.h.f., 40 – 230 MHz	≤ 1 dB; typ. 0,7 dB
v.h.f., 230 – 300 MHz, u.h.f. terminated with 75 Ω	$\leq 1,5$ dB; typ. 1,2 dB
u.h.f., v.h.f. terminated with 75 Ω	$\leq 1,5$ dB, typ. 0,9 dB
Suppression	
of u.h.f. frequencies at v.h.f. output	
40 – 230 MHz	≥ 15 dB
230 – 300 MHz	≥ 10 dB
measured at	
40 MHz	typ. 50 dB
200 MHz	typ. 22 dB
230 MHz	typ. 18 dB
300 MHz	typ. 11 dB
of v.h.f. frequencies at u.h.f. output	
470 – 890 MHz	≥ 13 dB
measured at	
470 MHz	typ. 14 dB
700 MHz	typ. 21 dB
890 MHz	typ. 22 dB
Contact resistance of connector	
after 1 plug insertion	
inner bush	≤ 10 m Ω
outer bush	≤ 5 m Ω
Insulation resistance	> 500 M Ω
Immunity from radiated interference	in conformity with requirements of BS 905, provided the assembly is installed in a professional manner, and a proper coaxial cable is used.

Quality assessment in production centres are according to the rules of BSI and VDE.

ENVIRONMENTAL DATA

Operating temperature range	0 to + 55 °C
Storage temperature range	-40 to + 85 °C
Relative humidity	≤ 95%
Maximum bump acceleration	25g
Maximum shock acceleration	50g
Maximum vibration amplitude	0,35 mm

MECHANICAL DATA

Dimensions in mm

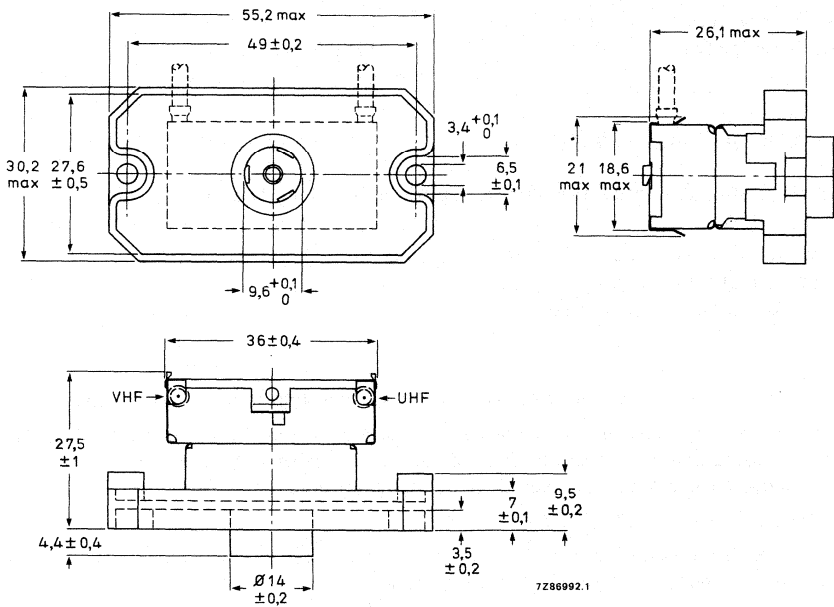

Fig. 2.

Mass 26 g approximately

Connector

Insertion force	≤ 50 N
Pull-out force	10 to 50 N
Pull-out force of inner bush, measured with a min. gauge of 2,29 mm dia., after 5 insertions of a max. plug gauge of 2,43 mm dia.	≥ 1 N
Loading of inner bush in axial direction for 5 s	≤ 50 N
Pull-out force of outer bush, measured with a min. plug gauge of 9 mm dia., after 5 insertions of a max. plug gauge of 9,5 mm dia.	$\geq 1,5$ N
Loading of outer bush in 4 radial and axial directions for 5 s	≤ 50 N

Marking

Moulded at the front of the fixing plate:

- PHILIPS
- 7105 (for the National Approbation Offices regarding the safety aspects)
- 250 V~, 390 pF 3x

Punched into one of the side faces of the metal housing:

- letter code for factory of origin
- production date code (year and week)

MOUNTING

The assembly can be mounted to the chassis of the TV set with two self-tapping screws, 4N x 9,5.

It must be connected to the tuner via coaxial cables with a diameter of 3 mm stripped according to Fig. 3. The inner cable conductors should be soldered to the inputs of splitters which line up with the cable inlets, the cable earth sheaths soldered to the metal housing.

The soldering conditions are: 340 °C, 2 s.

Plugs to be used with the assembly have to comply with the properties mentioned in DIN 45325, IEC 69-2 (9,5 mm diameter) and SNIR (9 mm diameter).

It is advised not to use aluminium plugs.

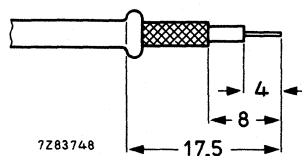

Fig. 3 Recommended cable stripping.
Cable length max. 150 mm.

CONVERSION LIST

CONVERSION LIST

CONVERSION LIST

catalogue number	type number	page
3111 107 15670	USF10	121
16270	USF10A	121
3111 237 10030	UV628/256	247
3111 267 10010	UV627	247
3112 200 20720	see U341/MK2	69
	see U342	84
3112 218 53420	UV616/256	223
53600	UV615	223
51790	U411	97
51810	U412/256	97
51830	V431	285
52290	U412/64	97
52400	U411/IEC	97
52410	U412/256/IEC	97
52420	U412/64/IEC	97
52660	UV417	165
52690	UV417/IEC	165
52720	UV418/256	165
52750	UV418/64	165
52780	UV418/256/IEC	165
52810	UV418/64/IEC	165
3112 221 01220	see U342	84
3112 274 13220	see U341/MK2	69
	see U342	84
3122 121 24910	see U341/MK2	69
29260	see U341/MK2	69
3122 127 01240		303
03310	UV471	209
03500		303
05900		303
08870	UV411/IEC	133
08880	UV412/256/IEC	133
08890	UV412/64/IEC	133
08900	UV412/64	133
09060	UV412/256	133
09710	M33	39
09750	M34	39
10260		307
10450		307
14730		307
19680	ELC3082	13
21300		313
24140		317
24360	UV411	133
25130	U342	71

CONVERSION LIST (continued)

catalogue number	type number	page
3122 127 36700	U344/IEC	85
37220	U343/IEC	85
37390	U344	85
37520	U343	85
41492	U341/MK2	55
41510	U342LO	71
42010	UV412	133
43392	U341LO/MK2	55
43630	UV431	177
48460	UV461	193
3122 131 63390	cross-head	163
3122 237 00010	UV618/256	235
3122 237 00020	UV461/IEC	193
00030	UV462/256	193
00040	UV462/256/IEC	193
00060	UV617	235
00070	M34/256	39
00200	UV411HKM/IEC	149
00230	UV636/256	259
00270	U743	109
00280	U743/IEC	109
00290	U743/IEC.L	109
00300	U744/256	109
00310	U744/256/IEC	109
00320	U744/256/IEC.L	109
00340	UV472/256	209
00360	UV472/64	209
10020	FE618QM/256	25
10030	FE618Q/256	25
10170	FE617QM	25
7122 005 47680	adjustment tool	53
47910	holder	163
7622 468 17940	see U343	96
8104 004 11040	adjustment tool	96

DATA HANDBOOK SYSTEM

DATA HANDBOOK SYSTEM

Our Data Handbook System comprises more than 60 books with specifications on electronic components, subassemblies and materials. It is made up of four series of handbooks:

ELECTRON TUBES	BLUE
SEMICONDUCTORS	RED
INTEGRATED CIRCUITS	PURPLE
COMPONENTS AND MATERIALS	GREEN

The contents of each series are listed on pages iv to vii.

The data handbooks contain all pertinent data available at the time of publication, and each is revised and reissued periodically.

When ratings or specifications differ from those published in the preceding edition they are indicated with arrows in the page margin. Where application information is given it is advisory and does not form part of the product specification.

Condensed data on the preferred products of Philips Electronic Components and Materials Division is given in our Preferred Type Range catalogue (issued annually).

Information on current Data Handbooks and on how to obtain a subscription for future issues is available from any of the Organizations listed on the back cover.

Product specialists are at your service and enquiries will be answered promptly.

ELECTRON TUBES (BLUE SERIES)

The blue series of data handbooks comprises:

- T1** **Tubes for r.f. heating**
- T2a** **Transmitting tubes for communications, glass types**
- T2b** **Transmitting tubes for communications, ceramic types**
- T3** **Klystrons**
- T4** **Magnetrons for microwave heating**
- T5** **Cathode-ray tubes**
Instrument tubes, monitor and display tubes, C.R. tubes for special applications
- T6** **Geiger-Müller tubes**
- T8** **Colour display systems**
Colour TV picture tubes, colour data graphic display tube assemblies, deflection units
- T9** **Photo and electron multipliers**
- T10** **Plumbicon camera tubes and accessories**
- T11** **Microwave semiconductors and components**
- T12** **Vidicon and Newvicon camera tubes**
- T13** **Image intensifiers and infrared detectors**
- T15** **Dry reed switches**
- T16** **Monochrome tubes and deflection units**
Black and white TV picture tubes, monochrome data graphic display tubes, deflection units

SEMICONDUCTORS (RED SERIES)

The red series of data handbooks comprises:

- S1 Diodes**
Small-signal silicon diodes, voltage regulator diodes (< 1,5 W), voltage reference diodes, tuner diodes, rectifier diodes
- S2a Power diodes**
- S2b Thyristors and triacs**
- S3 Small-signal transistors**
- S4a Low-frequency power transistors and hybrid modules**
- S4b High-voltage and switching power transistors**
- S5 Field-effect transistors**
- S6 R.F. power transistors and modules**
- S7 Surface mounted semiconductors**
- S8a Light-emitting diodes**
- S8b Devices for optoelectronics**
Optocouplers, photosensitive diodes and transistors, infrared light-emitting diodes and infrared sensitive devices, laser and fibre-optic components
- S9 Power MOS transistors**
- S10 Wideband transistors and wideband hybrid IC modules**
- S11 Microwave transistors**
- S12 Surface acoustic wave devices**
- S13 Semiconductor sensors**
- S14 Liquid Crystal Displays**

INTEGRATED CIRCUITS (PURPLE SERIES)

The purple series of handbooks comprises:

IC01	Radio, audio and associated systems Bipolar, MOS	published 1986
IC02a/b	Video and associated systems Bipolar, MOS	published 1986
IC03	Integrated circuits for telephony Bipolar, MOS	published 1986
IC04	HE4000B logic family CMOS	published 1986
IC05N	HE4000B logic family – uncased ICs CMOS	published 1984
IC06N	High-speed CMOS; PC74HC/HCT/HCU Logic family	published 1986
IC08	ECL 10K and 100K logic families	published 1986
IC09N	TTL logic series	published 1986
IC10	Memories MOS, TTL, ECL	new issue 1987
IC11N	Linear LSI	published 1985
Supplement to IC11N	Linear LSI	published 1986
IC12	I²C-bus compatible ICs	not yet issued
IC13	Semi-custom Programmable Logic Devices (PLD)	new issue 1987
IC14	Microcontrollers and peripherals Bipolar, MOS	new issue 1987
IC15	FAST TTL logic series	published 1986
IC16	CMOS integrated circuits for clocks and watches	published 1986
IC17	Integrated Services Digital Networks (ISDN)	not yet issued
IC18	Microprocessors and peripherals	new issue 1987

COMPONENTS AND MATERIALS (GREEN SERIES)

The green series of data handbooks comprises:

- C2 Television tuners, coaxial aerial input assemblies**
- C3 Loudspeakers**
- C4 Ferroxcube potcores, square cores and cross cores**
- C5 Ferroxcube for power, audio/video and accelerators**
- C6 Synchronous motors and gearboxes**
- C7 Variable capacitors**
- C8 Variable mains transformers**
- C9 Piezoelectric quartz devices**
- C11 Varistors, thermistors and sensors**
- C12 Potentiometers, encoders and switches**
- C13 Fixed resistors**
- C14 Electrolytic and solid capacitors**
- C15 Ceramic capacitors**
- C16 Permanent magnet materials**
- C17 Stepping motors and associated electronics**
- C18 Direct current motors**
- C19 Piezoelectric ceramics**
- C20 Wire-wound components for TVs and monitors**
- C22 Film capacitors**

Argentina: PHILIPS ARGENTINA S.A., Div. Elcoma, Vedia 3892, 1430 BUENOS AIRES, Tel. (01) 541 - 7141 to 7747.

Australia: PHILIPS INDUSTRIES LTD., Elcoma Division, 11 Waltham Street, ARTARMON, N.S.W. 2064, Tel. (02) 439 3322.

Austria: ÖSTERREICHISCHE PHILIPS INDUSTRIE G.m.b.H., UB Baugelemente, Triester Str. 64, A-1101 WIEN, Tel. (0222) 6291 11-0.

Belgium: N.V. PHILIPS & MBLE ASSOCIATED, 80 Rue Des Deux Gares, B-1070 BRUXELLES, Tel. (02) 525-61-11.

Brazil: CONSTANTA-IBRAPE; (Active Devices): Av. Brigadeiro Faria Lima, 1735-SAO PAULO-SP, Tel. (011) 211-2600,
(Passive Devices & Materials): Av. Francisco Monteiro, 702 - RIBEIRAO PIRES-SP, Tel. (011) 459-8211.

Canada: PHILIPS ELECTRONICS LTD., Elcoma Division, 601 Milner Ave., SCARBOROUGH, Ontario, M1B 1M8, Tel. (416) 292-5161.

Chile: PHILIPS CHILENA S.A., Av. Santa Maria 0760, SANTIAGO, Tel. (02) 77 38 16.

Colombia: IND. PHILIPS DE COLOMBIA S.A., c/o IPRELENZO LTD., Cra. 21, No. 56-17, BOGOTA, D.E., Tel. (01) 249 7624.

Denmark: MINIWATT A/S, Strandlodsvej 2, P.O. Box 1919, DK 2300 COPENHAGEN S, Tel. (01) 54 11 33.

Finland: OY PHILIPS AB, Elcoma Division, Kaivokatu 8, SF-00100 HELSINKI 10, Tel. (90) 172 71.

France: RTC-COMPELEC, 130 Avenue Ledru Rollin, F-75540 PARIS 11, Tel. (01) 4338 8000.

Germany (Fed. Republic): VALVO, UB Baugelemente der Philips G.m.b.H., Valvo Haus, Burchardstrasse 19, D-2 HAMBURG 1, Tel. (040) 3296-0.

Greece: PHILIPS HELLENIQUE S.A., Elcoma Division, No. 15, 25th March Street, GR 17778 TAVROS, Tel. (01) 4894339/4894 911.

Hong Kong: PHILIPS HONG KONG LTD., Elcoma Div., 15/F Philips Ind. Bldg., 24-28 Kung Yip St., KWAI CHUNG, Tel. (0)-245121.

India: PEICO ELECTRONICS & ELECTRICALS LTD., Elcoma Dept., Band Box Building,
254-D Dr. Annie Besant Rd., BOMBAY - 400 025, Tel. (022) 4930311/4930590.

Indonesia: P.T. PHILIPS-RALIN ELECTRONICS, Elcoma Div., Setiabudi II Building, 6th Fl., Jalan H.R. Rasuna Said (P.O. Box 223/KBY) Kuningan,
JAKARTA 12910, Tel. (021) 51 79 95.

Ireland: PHILIPS ELECTRICAL (IRELAND) LTD., Elcoma Division, Newstead, Clonskeagh, DUBLIN 14, Tel. (01) 693355.

Italy: PHILIPS S.p.A., Div. Componenti Elcoma, Piazza IV Novembre 3, I-20124 MILANO, Tel. (02) 6752.1.

Japan: NIHON PHILIPS CORP., Shuwa Shinagawa Bldg., 26-33 Takanawa 3-chome, Minato-ku, TOKYO (108), Tel. (03) 448-5611.
(IC Products) SIGNETICS JAPAN LTD., 8-7 Sanbancho Chiyoda-ku, TOKYO 102, Tel. (03) 230-1521.

Korea (Republic of): PHILIPS ELECTRONICS (KOREA) LTD., Elcoma Div., Philips House, 260-199 Itaewon-dong, Yongsan-ku, SEOUL,
Tel. (02) 794-5011.

Malaysia: PHILIPS MALAYSIA SDN BHD, Elcoma Div., 345 Jalan Gelugor, 11700 PULAU PINANG, Tel. (04) 870044.

Mexico: ELECTRONICA, S.A. de C.V., Carr. México-Toluca km. 62.5, TOLUCA, Edo. de México 50140, Tel. Toluca 91 (721) 613-00.

Netherlands: PHILIPS NEDERLAND, Marktgroep Elonco, Postbus 90050, 5600 PB EINDHOVEN, Tel. (040) 783749.

New Zealand: PHILIPS NEW ZEALAND LTD., Elcoma Division, 110 Mt. Eden Road, C.P.O. Box 1041, AUCKLAND, Tel. (09) 605-914.

Norway: NORSK A/S PHILIPS, Elcoma Dept., Sandstuveien 70, OSLO 6, Tel. (02) 68 02 00.

Pakistan: PHILIPS ELECTRICAL CO. OF PAKISTAN LTD., Philips Markaz, M.A. Jinnah Rd., KARACHI-3, Tel. (021) 72 57 72.

Peru: CADESA, Av. Alfonso Ugarte 1268, LIMA 5, Tel. (014) 326070.

Philippines: PHILIPS INDUSTRIAL DEV. INC., 2246 Pasong Tamo, P.O. Box 911, Makati Comm. Centre, MAKATI-RIZAL 3116, Tel. (02) 868951 to 59.

Portugal: PHILIPS PORTUGUESA S.A.R.L., Av. Eng. Duarte Pacheco 6, 1009 LISBOA Codex, Tel. (019) 683121.

Singapore: PHILIPS PROJECT DEV. (Singapore) PTE LTD., Elcoma Div., Lorong 1, Toa Payoh, SINGAPORE 1231, Tel. 35 02 000.

South Africa: S.A. PHILIPS (Pty) LTD., EDAC Div., 3rd Floor Rainer House, Upper Railway Rd. & Ove St., New Doornfontein, JOHANNESBURG 2001,
Tel. (011) 402-4600/07.

Spain: MINIWATT S.A., Balmes 22, BARCELONA 7, Tel. (03) 301 63 12.

Sweden: PHILIPS KOMPONENTER A.B., Lidingövägen 50, S-11584 STOCKHOLM 27, Tel. (08) 7821000.

Switzerland: PHILIPS A.G., Elcoma Dept., Allmendstrasse 140-142, CH-8027 ZÜRICH, Tel. (01) 488 22 11.

Taiwan: PHILIPS TAIWAN LTD., 150 Tun Hua North Road, P.O. Box 22978, TAIPEI, Taiwan, Tel. (02) 7120500.

Thailand: PHILIPS ELECTRICAL CO. OF THAILAND LTD., 283 Silom Road, P.O. Box 961, BANGKOK, Tel. (02) 233-6330-9.

Turkey: TÜRK PHILIPS TICARET A.S., Elcoma Department, İnönü Cad., No. 78-80, 80090 Ayazpasa (ISTANBUL), Tel. (01) 14359 10.

United Kingdom: MULLARD LTD., Mullard House, Torrington Place, LONDON WC1E 7HD, Tel. (01) 580 6633.

United States: (Active Devices & Materials) AMPEREX SALES CORP., Providence Pike, SLATERSVILLE, R.I. 02876, Tel. (401) 762-9000.
(Passive & Electromech. Dev.) MEPCO/CENTRALAB, INC., 2001 West Blue Heron Blvd, RIVIERA BEACH, Florida 33404,
Tel. (305) 881-3200.
(IC Products) SIGNETICS CORPORATION, 811 East Arques Avenue, SUNNYVALE, CA 94088-3409, Tel. (408) 991-2000.

Uruguay: LUZILECTRON S.A., Avda Uruguay 1287, P.O. Box 907, MONTEVIDEO, Tel. (02) 985395.

Venezuela: IND. VENEZOLANAS PHILIPS S.A., c/o MAGNETICA S.A., Calle 6, Ed. Las Tres Jotas, App. Post. 78117, CARACAS, Tel. (02) 2393931.

For all other countries apply to: Philips Electronic Components and Materials Division, International Business Relations, P.O. Box 218,
5600 MD EINDHOVEN, The Netherlands, Telex 35000 phtcnl